

Packet8 Virtual Office[®]

Business Phone System

6757i CT IP Phone

User Guide
Release 2.2
Rev 01

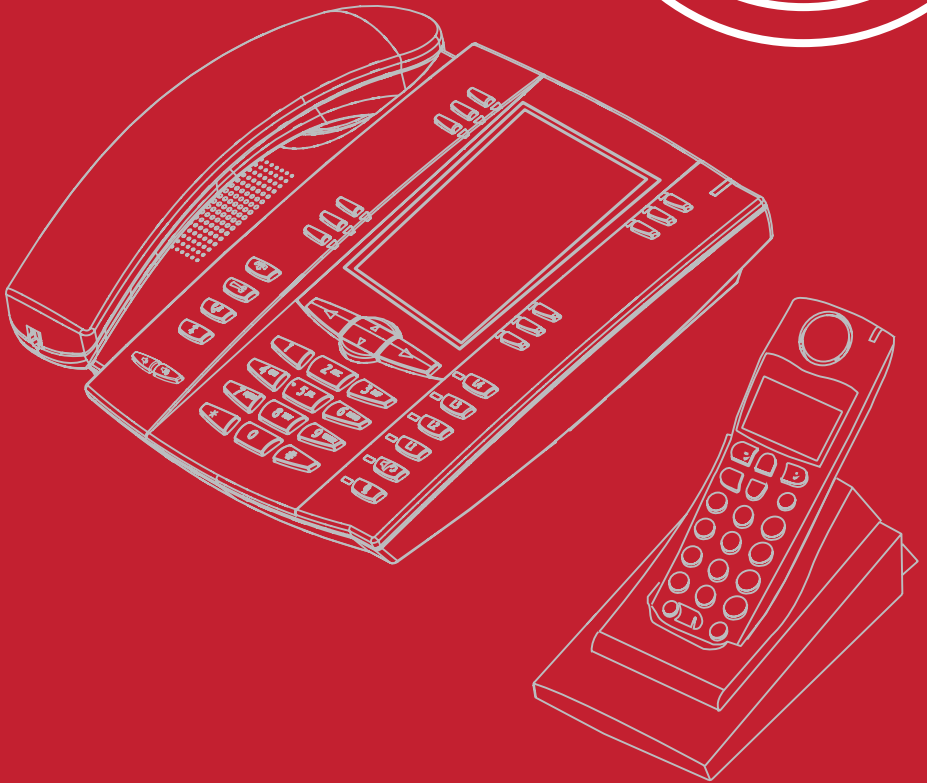

Table of Contents

Introduction	1
Phone Parts Checklist	1
Optional Accessories for 6757i CT (Not Included).....	3
Key Panels and Descriptions	4
6757i CT Base Unit Key Panel.....	4
Phone Features	5
Getting Started	6
Plugging in and Starting the Phone.....	6
Network Connected/Network Disconnected.....	9
Idle Screen.....	10
IP Phone Keys and Key Descriptions	13
Base Phone Keys.....	14
Base Phone Key Descriptions.....	14
Methods for Customizing Your Phone	17
Phone Options via the IP Phone UI	17
Phone Options via the Packet8 Web Phone UI	19
Phone Status	22
Phone Status via IP Phone UI.....	22
Phone Status via the Packet8 Web Phone UI	24
Customizing Your Phone	25
Ring Tones and Tone Sets.....	25
Contrast Level.....	28
Backlight.....	29
Live Dialpad*	31
Set Audio.....	32
Time and Date	34
User Password.....	40
Resetting a User Password.....	42
Restarting your phone	43
Phone Lock	44
Defining an Emergency Dial Plan.....	45
Line Keys and Softkeys	47
Multiple Line and Call Appearances.....	47
Softkeys	48
State-Based Softkeys (Bottom Keys only).....	50
Line Key	53
Speeddial Key	56
Do not Disturb (DND) Key.....	60
Flash Key	62
Services Key.....	63

Table of Contents

Directory Key	65
Phonebook	67
Intercom Key	69
None Key	71
Empty Key	72
Phone Lock Key	73
Deleting a Key	74
Making Calls	75
Dialing a Number	75
Pre-dialing a Number	75
To Call an Outside Number	76
To Call Another Extension	76
Making a Call	76
Receiving a Call	76
Using Handsfree Speakerphone	76
Using a Headset	77
Using Intercom	78
Redial	79
Mute	80
Receiving Calls	81
Answering an Incoming Call	81
Handling Calls	82
Placing a Call on Hold	82
Transferring Calls	83
Conferencing Calls	85
Ending Calls	88
Managing Calls	89
Phonebook	89
Callers List	98
Call Forwarding	104
Missed Calls Indicator	107
Voicemail System	108
Cordless Handset	113
Handset Keys	113
Handset Key Descriptions	114
Accessing Options on the Handset	115
Intercom	116
Ring Tone	116
Custom Name	117
Call timer	117
Vibrate	117
Handset Pairing	118

Table of Contents

Key Lock On or Off	118
Backlight	118
Silent Alert	119
Finding the Phones IP Address using the Handset	119
Feature Keys on the Handset	120
Idle Mode	122
Handset Icons and Status Messages	122
Multifunction Handset LED Indicator	123
Handset Keys	123
Battery Charging	125
Volume Control	126
Directory – Cordless Handset	126
Callers List - Cordless Handset	129
Making Calls from Cordless Handset	131
Pre-dialling a Number	131
Using a Headset	131
Receiving Calls	131
Call Privacy	131
Ending Calls	133
Pairing and Unpairing Cordless Handset to Base	133
Pairing Handset	133
Unpairing Handset	136
Additional Features	138
Suppressing DTMF Playback	138
Display DTMF Digits	140
Enable/Disable Call Waiting	141
Play Call Waiting Tone	143
Stuttered Dial Tone	144
Status Scroll Delay	145
Incoming Call Interrupts Dialing	146
Goodbye Key Cancels Incoming Calls	147
Message Waiting Indicator	149
Incoming Intercom Call Features	151
Model 536EM and 560EM Expansion Modules	153
Using the Expansion Modules	155
Troubleshooting Solutions	157
Appendix A - Time Zone Codes	1
Limited Warranty	5
What Is Covered?	5
Support	5

Introduction

This 6757i CT IP telephone has all the features of a regular business phone, allowing you to make and receive calls, transfer, conference and more. The 6757i CT IP telephone provides communications over an IP Network using the SIP IP telephony protocol.

Phone Parts Checklist

Remember to save your sales receipt in case you ever need warranty service. Check to make sure your package includes the items described below:

6757i CT IP Phone	Handset
Telephone Base Desk Legs	Power Adapter
Handset Cord	Wall Mount Drilling Template
Programmable Key Card	Ethernet Cable
CD Reference	Screws and Anchors for Wall Mount
Handset Battery	6757i CT Cordless Handset
Belt Clip	Charging Cradle for Handset

When you unpack your phone, you should ensure that you have all of the following items. Remember to save your sales receipt in case you ever need warranty service **6757i CT IP Phone Parts**

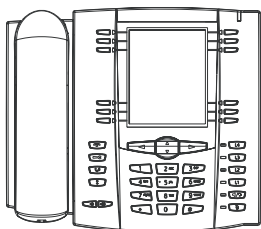

Telephone Base



Handset



Handset Cord

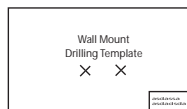

Wall Mount
Drilling Template



Power Adapter
(for 6757i CT Base)

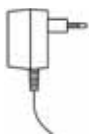

Power Adapter
(for charging cradle)



Belt Clip



Battery
Screws and
Anchors for
Wall Mounting



Ethernet Cable

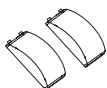

Telephone Base
Desk Legs



6757i CT Cordless
Handset

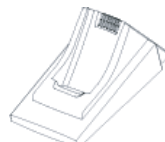

Charging Cradle
for Handset

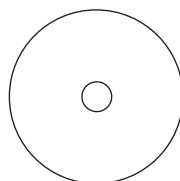

6757i CT
Reference CD

Optional Accessories for 6757i CT (Not Included)

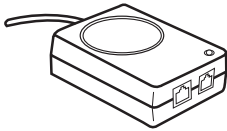

PoE (Power over Ethernet)
Inline Power Injector

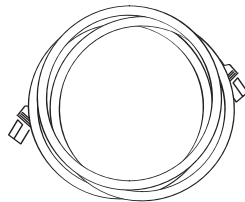

Additional Ethernet Cable
(category 5/5e straight
through cable)

A PoE (Power over Ethernet) inline power injector supplies 48v power to the 6757i CT through the Ethernet Cable on pins 4 & 5 and 7 & 8.



Important! Do not use this PoE inline power injector to power other devices.

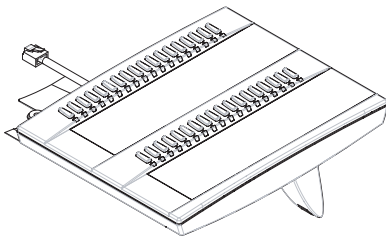

Model 536EM Expansion Module

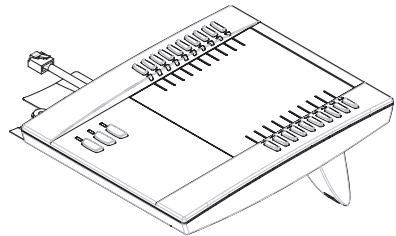

Model 560EM Expansion Module

The Model 536 Expansion Module (536EM) and Model 560 Expansion Module (560EM) attach to the right side of the 6757i CT phone. Model 536EM provides 36 additional softkeys for the phone. Model 560EM provides 60 additional softkeys. For more information about the expansion modules, see the section, [Model 536EM and 560EM Expansion Modules](#) on page [page 153](#).

Key Panels and Descriptions

6757i CT Base Unit Key Panel

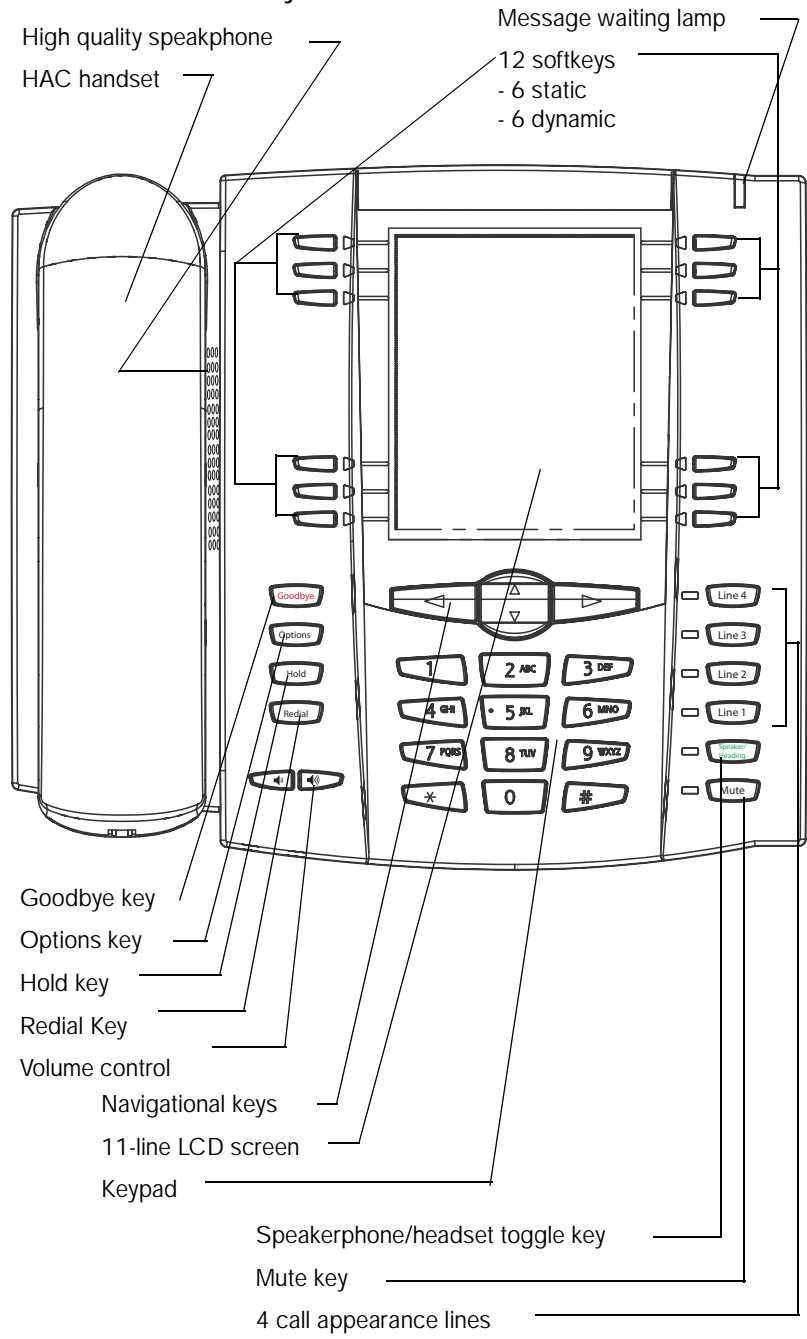

High quality speakerphone
HAC handset

Message waiting lamp
12 softkeys
- 6 static
- 6 dynamic

Goodbye key
Options key
Hold key
Redial Key
Volume control
Navigational keys
11-line LCD screen
Keypad

Speakerphone/headset toggle key
Mute key
4 call appearance lines

Phone Features

- 11 line graphical LCD screen (144 x 128 pixels) with white backlight
- 12 multi-functional softkeys
 - 6 Top Keys: Static softkeys
(up to 10 programmable functions)
 - 6 Bottom Keys: State-based softkeys
(up to 20 programmable functions)
- 4 call appearance lines with LEDs
- Supports up to 9 call lines
- Full-duplex speakerphone for handsfree calls
- Headset support (modular connector)
- Built-in-two-port, 10/100 Ethernet switch - lets you share a connection with your computer.
- Inline power support (based on 802.3af standard) which eliminates power adapters.
- AC power adapter (included)
- Enhanced busy lamp fields*
- Set paging*

Cordless Handset Features

- 5 line backlit display screen
- 2 multi-functional softkeys
- Programmable function key supports up to 14 functions
- Vibration Alerter
- Headset Jack
- Desk charging stand

* Availability of feature dependant on your phone system or service provider.

Getting Started

The 6757i CT must be set up and be configured prior to its first use. This section describes phone behavior and start up screens you may see when the phone is first plugged in, or when it is restarted.

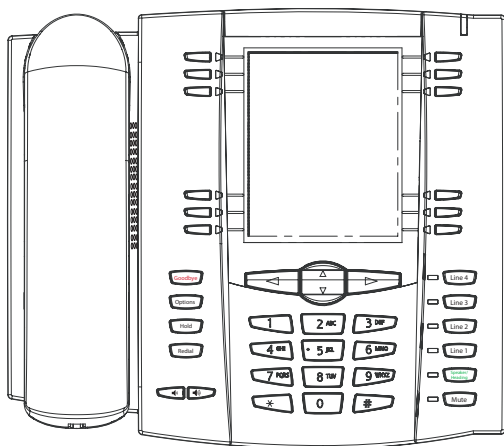

Plugging in and Starting the Phone

The 6757i CT automatically begins the start up sequence as soon as it is connected. The phone goes through this process the first time you plug in your phone and every time you restart your phone. The phone displays the following startup screens.

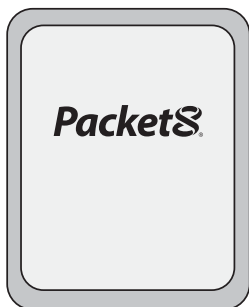



The 6757i CT phone then checks settings and looks for new configuration and firmware updates for the phone from a server. If a new update is found, the phone displays the message **Updating Configuration**. This may take a few moments while the phone downloads the latest updates.



Note: New updates to your phone can be automatically scheduled from the server. This is set up on the phone system by your System Administrator and should be scheduled during non-business hours or slow call periods.



Important! Do not unplug or remove power to the phone while it is checking or installing firmware and configuration information.

If language packs were loaded to your phone by your System Administrator, the following screen displays during startup.



When the configuration update is complete, the phone displays the following screens and then displays the **Idle** screen.

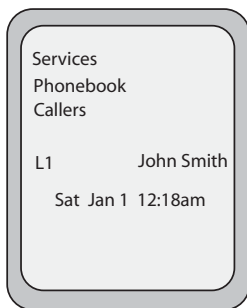

Idle Screen

Network Connected/Network Disconnected

If your phone is successful when connecting to the network the following screen displays before changing to the **Idle** screen.



If your phone did not successfully connect to the network, the **Network Disconnected** prompt appears on the display and the telephone status light turns on.

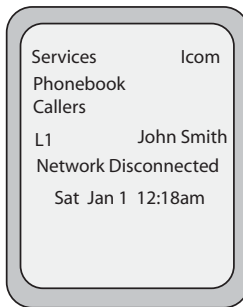

Check that the cables are tightly connected to the phone and to the wall jack. The phone should automatically detect when it is reconnected and displays the **Network Connected** prompt for a few seconds. However, if changes have been made to your phone's network settings, you may need to restart your phone.

For more information about connecting your phone, see the *Packet8 6757i CT IP Phone User Reference Manual*.

Check with your system or network administrator for assistance.

Idle Screen

When the phone has successfully updated the configuration and connected to the network, the phone displays the **Idle State** screen. The idle screen is shown whenever your phone is not in use.

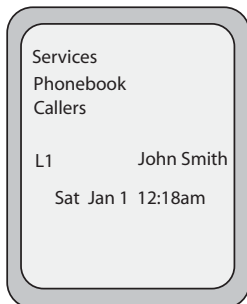

Note: Your System Administrator sets up your SIP screen name, line number, and any other administrative features required. If your name does not display on the screen, contact your System Administrator.

The **Idle State** screen lists your name day, date, and time. In the above screen, the "L1" indicates John Smith is configured on Line 1.

By default, the top softkeys 1 through 4 are configured for Services, Directory, Callers List, and Intercom, respectively. You can configure the 6 top keys with up to 10 functions, and the 6 bottom softkeys with up to 20 functions as required.

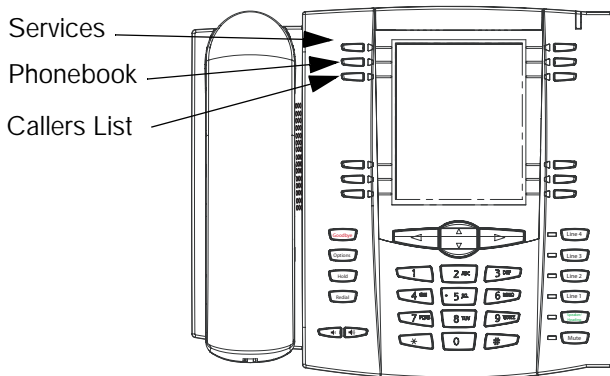

Reference

For more information about configuring the top and bottom softkeys, see "Softkeys" on page 48.

For more information about using the Services, Directory, Callers List, Intercom, Dial, Conference, and Transfer keys, see the following sections:

- "Making Calls" on page 75.
- "Handling Calls" on page 82.
- "Managing Calls" on page 89.

Idle Screen With Softkeys Configured

If you or your administrator have configured softkey functions on your phone, the labels for those functions display on the screen. For example, in the following illustration, "Home" was configured as a speeddial key on the bottom set of softkeys and "Do Not Disturb" (DND) was configured on the top set of softkeys.

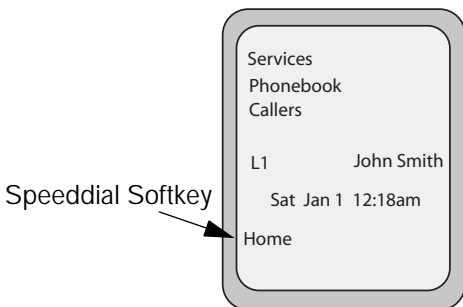

Idle Screen

You can configure up to 10 functions on the top set of softkeys. If you have additional functions configured on the top softkeys that do not display on the main idle screen, a **More** displays at the top right of the screen. Pressing the **More** softkey toggles between the first screen and a second screen of softkeys configured on your phone.



Idle Screen

Idle Screen with Voicemail Messages

The envelope icon  displays on the Idle State screen only if you have new messages waiting. The number next to the envelope indicates how many new messages you have.

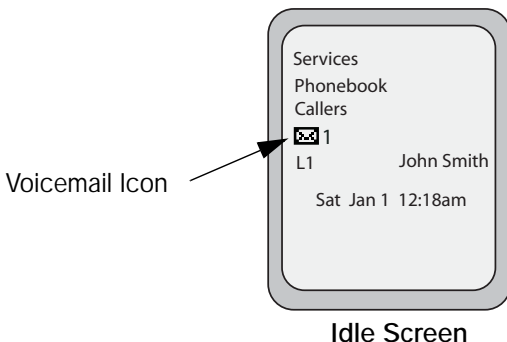

To access your voicemail messages, use the softkey that has been configured on your phone.

Screen Display After Picking Up the Handset

When you pick up the handset, the screen displays as follows:

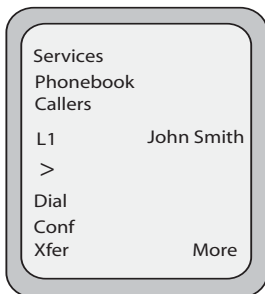

This screen displays the following keys located on the bottom left of the screen:

- Dial
- Conf (Conference)
- Xfer (Transfer)

A **More** softkey also displays at the bottom right of the screen if you have configured softkeys other than the default softkeys.

For example, if you configure a bottom softkey for speeddialing to Home, and then you pick up the handset, the screen displays the **Dial**, **Conf**, and **Xfer** default softkeys with a **More** softkey. You can press the **More** softkey to toggle between the first and second screens to display all configured softkeys. See illustrations below.

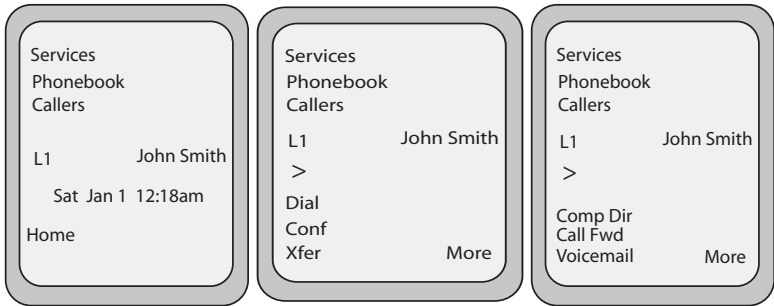

Idle Screen

After Handset Pickup

After Pressing "More"



Note: The bottom set of 6 softkeys map to the current state-based configurable softkeys. The top set of 6 softkeys allow you to configure up to 10 functions.

IP Phone Keys and Key Descriptions

The following section describes the Base Phone keys and key descriptions. For information about the Handset Keys and Handset Key Descriptions, see ["Handset Keys"](#) on page 113.



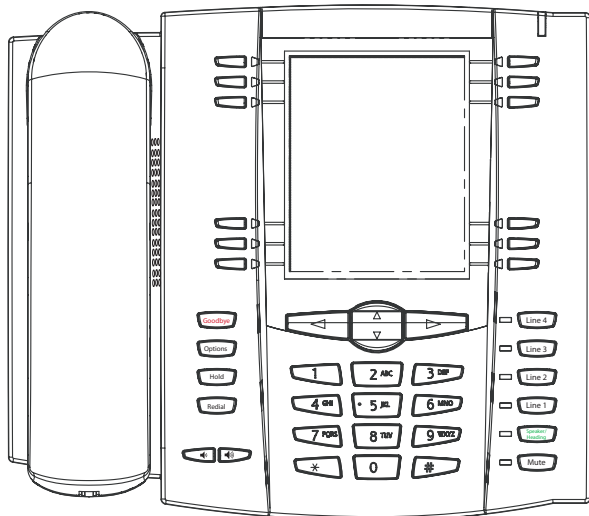

Base Phone Keys



The following section describes the 6757i CT base phone key functions, and how they help you make and manage your calls and caller information.

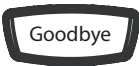

Base Phone Key Descriptions

The following table identifies the keys on the key panel of your 6757i CT IP phone that you can use for handling calls.

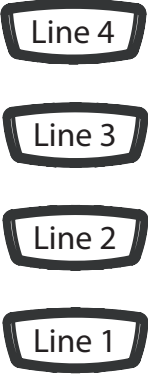
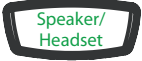
Keys	Key Description
	Goodbye key - Ends an active call. The Goodbye key also exits an open list, such as the Options List, without saving changes.
	Options key - Accesses options to customize your phone. Your System Administrator may have already customized some of your settings. Check with your System Administrator the administrator-only options.
	Hold key - Places an active call on hold. To retrieve a held call, press the call appearance button beside the light that is flashing.
	Redial key - Redials up to 100 previously dialed numbers. Pressing the Redial key twice simultaneously redials the last dialed number.
	Volume control key - Adjusts the volume for the handset, headset, ringer, and handsfree speaker.

Keys	Key Description
	<p>Line/Call Appearance key - Connects you to a line or call. The Packet8 6757i CT IP phone supports up to 4 line keys.</p>
	<p>Handsfree key - Activates Handsfree for making and receiving calls without lifting the handset. When the audio mode option is set, this key is used to switch between a headset and the handsfree speakerphone.</p>
	<p>Mute key - Mutes the microphone so that your caller cannot hear you (the light indicator flashes when the microphone is on mute).</p>
	<p>Navigation keys - Pressing the UP and DOWN arrow keys lets you view different status and text messages on the LCD display (if there are multiple status/text messages). These buttons also let you scroll through menu selections, such as the Options List.</p> <p>Pressing the LEFT and RIGHT arrow keys lets you view the different line/call appearances. While in the Options List, these keys allow you to exit or enter the current option. When you are editing entries on the display, pressing the LEFT arrow key erases the character on the left; pressing the RIGHT arrow key sets the option.</p>

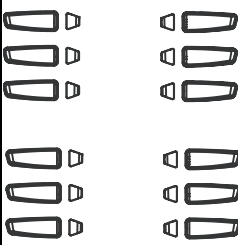
Keys	Key Description								
	<p>Softkeys - 12 softkeys on the 6757i CT IP Phone.</p> <ul style="list-style-type: none"> - 6 Top Keys: static softkeys (up to 10 programmable functions) - 6 Bottom Keys: state-based softkeys (up to 20 programmable functions) <p>All top and bottom keys can be configured for specific functions.</p> <p>By default, keys 1 through 4 are assigned as Services, Phonebook, and Callers List, respectively:</p> <table border="0" style="width: 100%;"> <tr> <td style="width: 20%;">1 - Services</td> <td>Accesses enhanced features and services such as XML applications and voicemail, provided by third parties.</td> </tr> <tr> <td>2 - Phonebook</td> <td>Accesses the Phonebook which displays up to 200 names and phone numbers (stored in alphabetical order)</td> </tr> <tr> <td>3 - Callers</td> <td>Accesses the Callers List which lists the last 200 calls received.</td> </tr> <tr> <td>4 - Line 1</td> <td></td> </tr> </table> <p>The following softkeys display when you pick up the handset:</p> <p>Dial - After entering a phone number from the keypad, you can press the Dial softkey to immediately dial the number. Conf - Begins a conference with the active call. Xfer - Transfers the active call to another number.</p> <p>Note: For more information about programming the softkeys to perform specific functions, see the "Softkeys" on page 48.</p>	1 - Services	Accesses enhanced features and services such as XML applications and voicemail, provided by third parties.	2 - Phonebook	Accesses the Phonebook which displays up to 200 names and phone numbers (stored in alphabetical order)	3 - Callers	Accesses the Callers List which lists the last 200 calls received.	4 - Line 1	
1 - Services	Accesses enhanced features and services such as XML applications and voicemail, provided by third parties.								
2 - Phonebook	Accesses the Phonebook which displays up to 200 names and phone numbers (stored in alphabetical order)								
3 - Callers	Accesses the Callers List which lists the last 200 calls received.								
4 - Line 1									

Methods for Customizing Your Phone

There are two ways to customize specific options on your phone:

- Using the Options  key on the IP Phone
- Using the Packet8 Web Phone UI in an Internet browser window from your PC.

Phone Options via the IP Phone UI

You can customize your phone by pressing the Options  key and accessing the IP Phone UI.

These options allow you to customize the following phone settings.

Option Number	Option
1	Call Forward 1. C fwd Number 2. C fwd Mode 3. No. Rings
2	Preferences 1. Tones Ring Tone Tone Set 2. Contrast Level 3. Live Dialpad 4. Set Audio Audio Mode Headset Mic Vol 5. Time and Date Time Zone Daylight Saving Time Format Date Format Time Server Time Server 1 Time Server 2 Time Server 3 Set Time Set Date 6. Language
3	Phone Status 1. IP&MAC Addresses 2. LAN Port 3. PC Port 4. Firmware Info
4	User Password
5	Administrator Menu (Password Protected)
6	Restart Phone
7	Phone Lock



Note: The Administrator Menu options are administrator level functions only, and are not accessible by the user. These options should only be set up and changed by your system administrator.

Simplified Options Menu



Your System Administrator may configure a simplified options menu for your phone. The following table indicates the options that may appear on your phone if the simplified options menu is applied.

Option Number	Option
1	Call Forward 1. Cfwd Number 2. Cfwd Mode 3. No. Rings
2	Preferences 1. Tones Ring Tone Tone Set 2. Contrast Level 3. Live Dialpad 4. Set Audio Audio Mode Headset Mic Vol
3	Phone Status 1. IP&MAC Addresses 2. LAN Port 3. PC Port 4. Firmware Info
4	Phone Lock

Using the IP Phone UI



IP Phone UI

1. Press the Options key  on the phone to enter the Options List.
2. To go to an **Option**, use ▲ and ▼ to scroll through the list, or press the number corresponding to the **Option**.
3. Press the **Show** softkey, the ► button, or press the digit number for the corresponding option to select the option.
4. Use the softkeys that display for each option to change a selected option.
5. Press the **Done** button to save the change.
6. Press the  button, the ◀ button, or the  button at any time to exit without saving changes.

References

For more information about customizing your phone using the available options from the IP Phone UI, see the section "[Customizing Your Phone](#)" on [page 25](#).

For more information about administrator options, contact your System Administrator.

Phone Options via the Packet8 Web Phone UI

In addition to the IP Phone UI options, you can also customize additional options on the IP Phone using the Packet8 Web Phone UI. In order to access your phone using the Packet8 Web Phone UI, you need to know your phone's IP address. To find your phone's IP address, see "[Finding Your Phone's IP Address](#)" on [page 23](#).

Using the Packet8 Web Phone UI



Packet8 Web Phone UI

1. Open your web browser, enter the phone's IP address or host name into the address field and press <Enter>. The following logon screen displays.

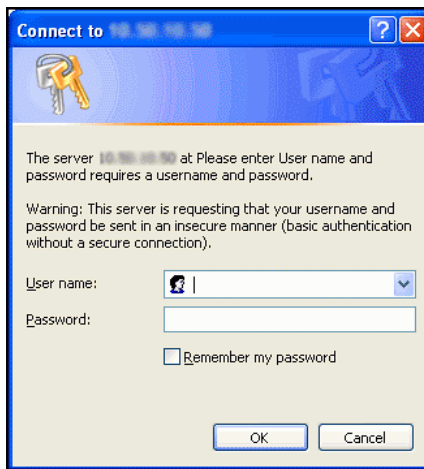

2. At the prompt, enter your username and password and click . The Network Status window displays for the IP phone you are accessing.



Note: For a user, the default user name is "user" and the password field is left blank.

Packet8 6753i
Log Off

Status
System Information

Operation
User Password
Phone Lock
Programmable Keys
Directory
Reset

Basic Settings
Preferences
Call Forward

Network Status

Attribute	LAN Port	PC Port
Link State	Up	Down
Negotiation	Auto	Auto
Speed	10Mbps	10Mbps
Duplex	Half	Half
MAC Address:	00-08-5D-16-11-34	

Hardware Information

Attribute	Value
Platform	53i Revision 0

Firmware Information

Attribute	Value
Firmware Version	2.1.0.2145
Firmware Release Code	SIP
Boot Version	1.1.0.1217
Date/Time	Jun 20 2007 05:46:04

3. You can logout of the Packet8 Web Phone UI at any time by clicking **Log Off**.

The following categories display in the side menu of the Packet8 Web Phone UI: **Status, Operation, Basic Settings.**

Headings	Descriptions
Status	The Status section displays the network status and the MAC address of the IP phone. It also displays hardware and firmware information about the IP phone. The information in the Network Status window is read-only.
Operation	<p>User Password - Allows you to change user password.</p> <p>Phone Lock - Allows you to assign an emergency dial plan to the phone, lock the phone to prevent any changes to the phone and to prevent use of the phone, and reset the user password.</p> <p>Softkeys and XML - Allows you to configure up to 6 top softkeys and 6 bottom softkeys with functions identified in the list below. You can configure up to 10 functions on the top softkeys and up to 20 functions on the bottom softkeys.</p> <p>Available Functions for Softkeys Not all functions in the following table supported by Packet8.</p> <ul style="list-style-type: none"> • None • Line • Speeddial • Do Not Disturb (DND) • Busy Lamp Field (BLF) • Extensible Markup Language (XML) • Flash • Empty • Sprecode • Pickup • Directory • Callers List • Intercom • Services • Phone Lock <p>Expansion Modules - Allows you to configure an additional 36 softkeys with a 536EM Expansion Module, or an additional 60 softkeys with a 560EM Expansion Module if an it is attached to the phone. This option displays on the side menu of the Packet8 Web Phone UI only if an Expansion Module is attached.</p> <p>Note: Not all functions in the table above apply to the Expansion Modules.</p> <p>Directory - Allows you to copy the Callers List and Phonebook from your IP phone to your PC.</p> <p>Reset - Allows you to restart the IP phone when required.</p>

Headings	Descriptions
Basic Settings	<p>Preferences - Allows you to enable/disable the following:</p> <ul style="list-style-type: none"> • Static Pickup call • Suppress DTMF Playback • Display DTMF Digits • Call Waiting • Play Call Waiting Tone • Stuttered Dial Tone • XML Beep Support • Status Scroll Delay • Incoming Call Interrupts Dialing • Goodbye Key Cancels Incoming Call • UPnP Mapping Lines • Message Waiting Indicator Line <p>This category also allows you to configure:</p> <ul style="list-style-type: none"> • Incoming Intercom Call Settings • Ring Tones (global and per-line basis) • Ring Tone Sets • Time and Date Settings • Language Settings. <p>Call Forward - Allows you to set a phone number destination for where you want calls forwarded. Call forward can be configured using a specific mode (off, all, busy, no answer, busy no answer) on a global or per-line basis.</p>

Phone Status

You can view the status of your phone using the IP Phone UI or the Packet8 Web Phone UI.

Phone Status via IP Phone UI

The **Phone Status** option on the IP phone displays the status of your phone to the LCD display.

This option allows you to view your phone's:

- Network status including your phone's IP and MAC address
- Local Area Network (LAN) port
- PC port
- Firmware version

Use the following procedure to view the status of your phone using the IP Phone UI



IP Phone UI

1. Press  on the phone to enter the Options List.
2. Select **Phone Status**.
3. Select the option you want to view:

IP&MAC Address

LAN Port

PC Port

Firmware Info

The option you select displays to the LCD. Use the ▲ and ▼ keys to scroll through the LCD display.

Finding Your Phone's IP Address

If you want to access your phone's options using an Internet browser, you need to enter the IP address of the phone in the browser to open the Packet8 Web Phone UI. Use the following procedure to find your phone's IP address.



IP Phone UI

1. Press  to enter the Options List.
2. Use ▼ to scroll down the list of options to **Phone Status** and press **Select**.

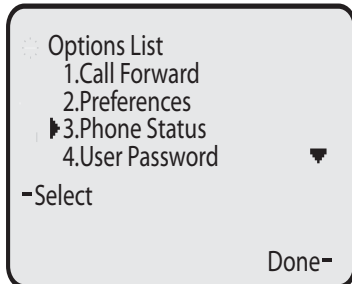

3. Use ▼ to scroll to **IP&MAC Addresses** and press **Select**.

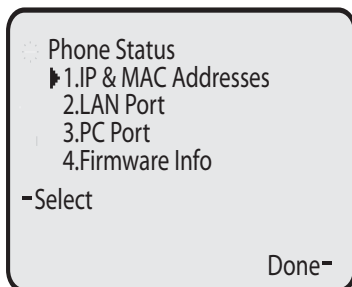

The following screen displays that specifies the IP Address and MAC Address of your phone. Use the IP Address to enter into your browser win-

How to access the phone via the Packet8 Web Phone UI. For more information about using the Packet8 Web Phone UI, see "[Phone Options via the Packet8 Web Phone UI](#)" on [page 19](#).

Attr.	Port0	Port1
LinkStat.	Link	N/Link
Negotiat.	Auto	Auto
Speed	100M	10M
Duplex	Full	Half
- IP Addr		
- MAC Addr		
Done-		

Phone Status via the Packet8 Web Phone UI

After accessing your phone via the Packet8 Web Phone UI, the first screen to display is the phone's Status Screen.

The screenshot shows the Packet8 Web Phone UI interface for model 6753i. The top right corner displays '6753i' and a 'Log Off' link. The left sidebar contains a navigation menu with categories: Status (System Information), Operation (User Password, Phone Lock, Programmable Keys, Directory, Reset), and Basic Settings (Preferences, Call Forward). The main content area is titled 'Network Status' and contains the following information:

Attribute	LAN Port	PC Port
Link State	Up	Down
Negotiation	Auto	Auto
Speed	10Mbps	10Mbps
Duplex	Half	Half
MAC Address:	00-08-5D-16-11-34	

Below the Network Status section is the 'Hardware Information' section:

Attribute	Value
Platform	53i Revision 0

Below the Hardware Information section is the 'Firmware Information' section:

Attribute	Value
Firmware Version	2.1.0.2145
Firmware Release Code	SIP
Boot Version	1.1.0.1217
Date/Time	Jun 20 2007 05:46:04

This screen is view only. It displays the Network Status of your phone which includes the following:

- LAN Port
- PC Port
- MAC Address
- Hardware Information
- Firmware Information

Customizing Your Phone

The following paragraphs describe the options available from either the IP Phone UI, the Packet8 Web Phone UI, or both, and provide procedures applicable to the option.

Ring Tones and Tone Sets

You can configure ring tones and ring tone sets on the IP phone.

Ring Tones

There are several distinct ring tones a user can select from to set on the IP phones. You can enable/disable these ring tones on a global or per-line basis.

The following table identifies the valid settings and default values for each type of configuration method.

Ring Tones Table

Configuration Method	Valid Values	Default Value
IP Phone UI	Global: Tone 1 Tone 2 Tone 3 Tone 4 Tone 5	Global: Tone 1
Packet8 Web Phone UI	Global: Tone 1 Tone 2 Tone 3 Tone 4 Tone 5 Silent	Global: Tone 1
	Per-Line: Global Tone 1 Tone 2 Tone 3 Tone 4 Tone 5 Silent	Per-Line: Global

Ring Tone Sets

In addition to ring tones, you can configure ring tone sets on a global-basis on the IP phone. Ring tone sets consist of tones customized for a specific country. The ring tone sets configurable on the IP phones are:

- US (Default - also used in Canada)
- Mexico
- United Kingdom
- Italy
- Germany
- France
- Europe (generic tones)
- Australia

When you configure the country's tone set, the country-specific tone is heard on the phone for the following:

dial tone
secondary dial tone
ring tone
busy tone
congestion tones
call waiting tone
ring cadence pattern

You configure global ring tones and tone sets using the Packet8 Web Phone UI and the IP Phone UI.

Configuring Ring Tones and Tone Sets



IP Phone UI

Use the following procedures to configure ring tones and tone sets on the IP phone. (global configuration only).

1. Press  on the phone to enter the Options List.
2. Select **Preferences**.
3. Select **Tones**.
4. Select **Ring Tone**.
5. Select the type of ring tone (**Tone 1** through **Tone 5**, or **Silent**).
6. Press **Done**.
7. Select **Tone Set**.

- Select the country for which you want to apply the tone set. Valid values are **Australia, Europe, France, Germany, Italy, UK, Mexico, and US**. Default is **US**.
- Press **Done**. The ring tone and tone set you select is immediately applied to the IP phone.



Packet8 Web Phone UI

- Click on **Basic Settings->Preferences->Ring Tones**.

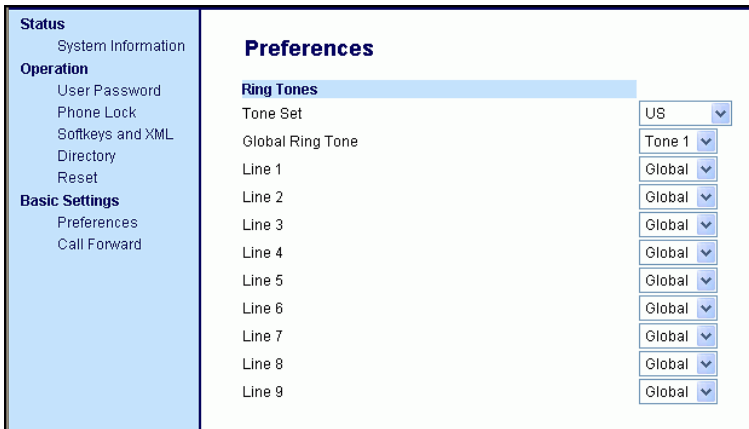

For global configuration:

- In the **"Ring Tones"** section, select a country from the **"Tone Set"** field. Valid values are **Australia, Europe, France, Germany, Italy, UK, Mexico, and US**. Default is **US**.
- Select a value from the **"Global Ring Tone"** field.



Note: See the [Ring Tones and Tone Sets](#) on [page 25](#) for valid values.

For per-line configuration:

- In the **Ring Tone** section, select a line for which you want to set ring tone.
- Select a value from the **LineN** field.



Note: See the [Ring Tones and Tone Sets](#) on [page 25](#) for valid values.

- Click  to save your settings.

Contrast Level

The **Contrast Level** option on the IP phone allows you to set the amount of light that illuminates the LCD display. Use this option to set the preference of contrast level.

You can set the contrast level using the IP Phone UI only.

Setting Contrast Level



IP Phone UI

1. Press  on the phone to enter the Options List.
2. Select Preferences.
3. Select **Display**.
4. Select **Contrast Level**.

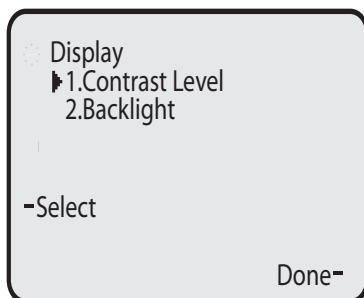

5. Use the ◀ and ▶ navigation buttons to increase or decrease the intensity of contrast lighting on the LCD.

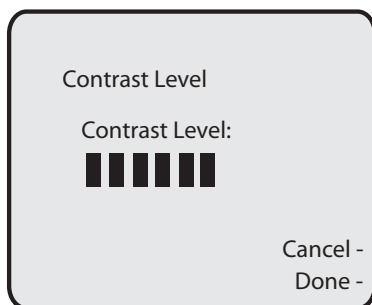

6. Press **Done** to save your selection.

Backlight

The **Backlight** option on the IP phone allows you to set the backlight status on the LCD display to the following:

- Always ON (Default)
- Always OFF
- Automatically turn ON the backlight when the phone is in use, and then automatically turn OFF the backlight when the phone is idle after a specified length of time.

Auto backlighting sets the phone to turn off the backlighting after a period of inactivity; the idle period is user definable under the Advanced softkey when you select the Auto mode. In Auto mode, the backlight turns on with a key press or state change on the phone.

Setting the Backlight



IP Phone UI

1. Press  on the phone to enter the Options List.
2. Select **Preferences**.
3. Select **Display**.
4. Select **Backlight**.

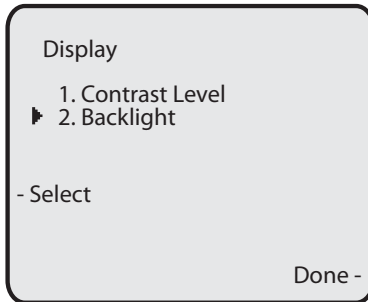

5. Use the ▲ and ▼ navigation buttons to select the Backlight status for your phone. Default is **ON**. Available options are:
 - Off
 - On (Default)
 - Auto

6. If you selected **On** or **Off**, press **Done** to save your setting.

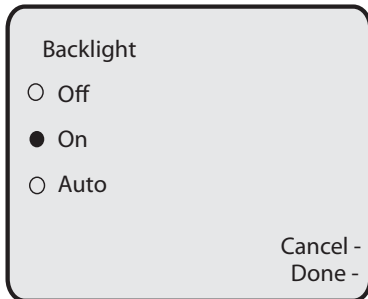

7. If you selected **Auto**, press the **Advanced** softkey.

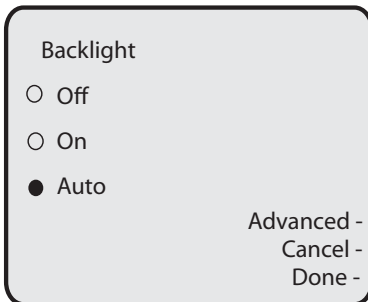

8. Using the keypad, enter the amount of seconds you want the phone to stay backlit when the phone is idle. Default is **10 seconds**. When this period of time is reached, the phone turns OFF the backlight. Use the **Backspace** and/or **Clear** softkeys to delete entries if required.

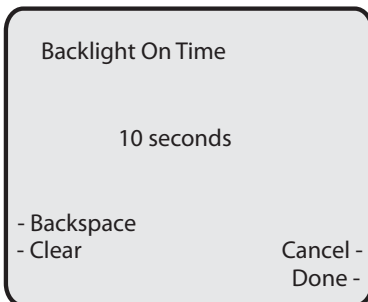

9. Press **Done** to save your setting.

Live Dialpad*

The **Live Dialpad** option on the IP phone turns the Live Dialpad mode ON or OFF. With live dialpad ON, the 6757i CT IP phone automatically dials out and turns ON Handsfree mode as soon as a dialpad key or softkey is pressed. With live dial pad OFF, if you dial a number while the phone is on-hook, lifting the receiver or pressing the  initiates a call to that number.

*Availability of feature dependent on your phone system.

You can enable/disable the live dialpad using the IP Phone UI only.

Enabling/Disabling Live Dialpad



IP Phone UI

1. Press  on the phone to enter the Options List.
2. Select **Preferences**.
3. Select **Live Dialpad**.

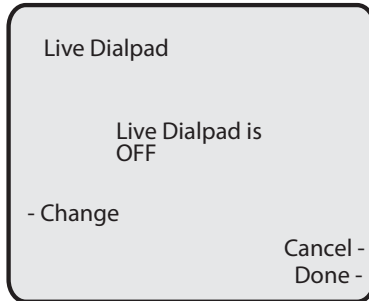

4. Use the **Change** softkey to turn the live dialpad ON or OFF.
5. Press **Done** to save your setting.





Set Audio

The **Set Audio** option on the IP Phone allows you to set the audio mode for your IP phone. It also allows you to set the volume level of the headset microphone.

You can set Audio on your IP phone using the IP Phone UI only.

Audio Mode

The 6757i CT allows you to use a handset, a headset, or handsfree mode to handle incoming and outgoing calls. The audio mode option provides different combinations of these three methods to provide maximum flexibility in handling calls. There are four audio mode options you can set:

Audio Mode Option	Description
Speaker	This is the default setting. Calls can be made or received using the handset or handsfree speakerphone. In handset audio mode, pressing the  button on the phone switches to handsfree speakerphone. In Speaker audio mode, lift the handset to switch to the handset.
Headset	Choose this setting if you want to make or receive all calls using a handset or headset. Calls can be switched from the handset to headset by pressing the  button on the phone. To switch from the headset to the handset, lift the handset.
Speaker/Headset	Incoming calls are sent to the handsfree speakerphone first when the  button is pressed. By pressing the button again, you can switch back and forth between the handsfree speakerphone and the headset. At anytime, lifting the handset switches back to the handset from either the handsfree speakerphone or the headset.
Headset/Speaker	Incoming calls are sent to the headset first when the  button is pressed. By pressing the button again, you can switch back and forth between the headset and the handsfree speakerphone. At anytime, lifting the handset switches back to the handset from either the headset or the handsfree speakerphone.

Headset Mic Volume

The **Headset Mic Volume** option allows you to set the volume level for the headset microphone.

Setting Audio Mode and Headset Mic Volume



IP Phone UI

1. Press  on the phone to enter the Options List.
2. Select **Preferences**.
3. Select **Set Audio**.
4. Select **Audio Mode**.

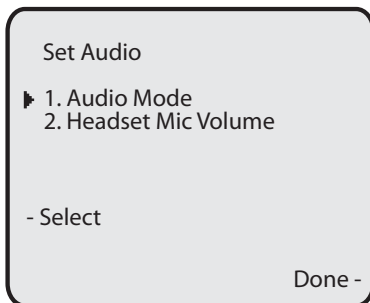

5. Select the audio mode you want to use on your phone. Default is **Speaker**.
Valid values are:
Speaker (Default)
Headset
Speaker/Headset
Headset/Speaker

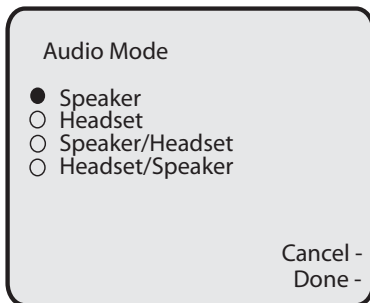

6. Press **Done** to save your setting.

7. Select **Headset Mic Volume**.

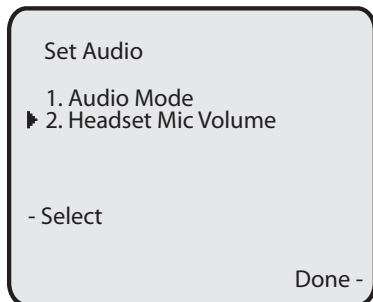

8. Select the **Low**, **Medium**, or **High** volume level. Default is **Medium**.

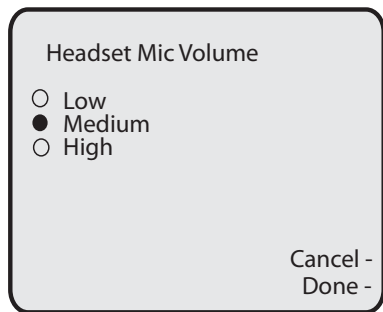

9. Press **Done** to save your selection.

Time and Date

On the IP phones, you can configure the following:

- Time and Date
- Time and Date Format
- Time Zone
- Daylight Saving Time
- Time Servers (Administrator use only; pass word protected)



Note: You can set the above features using the IP Phone UI. However, only the Time and Date Formats can be set using the Packet8 Web Phone UI. The "Time Server" configuration is for Administrator use only and is password protected. Contact your System Administrator for more information.

Configuring Time and Date

Use the following procedures to configure the time and date settings on the IP phone.



IP Phone UI

Set Time and Time Format



Note: The time and time format you configure display on the phone's idle screen.

1. Press  on the phone to enter the Options List.
2. Select **Preferences**.
3. Select **Time and Date**.
4. Select **Set Time**.

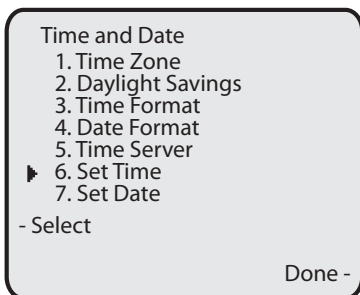

5. Using the keys on the keypad, enter a time to set on the IP phone. Use the **Backspace** softkey to move back a space and delete a character. Use the **AM/PM** softkey to specify either AM or PM for the time setting.

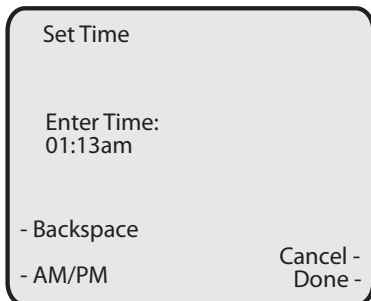

6. Press **Done** to save the setting.
7. Select **Time Format**.
8. Using the **Change** softkey, set the Time Format to either a 12 hour format or a

24 hour format. Valid values are **12h** and **24h**. Default is **12h**.

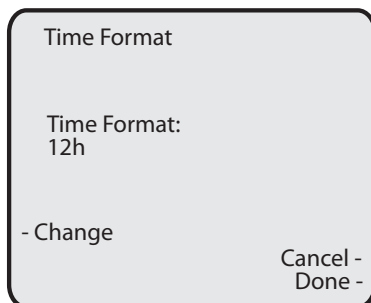

9. Press **Done** to save the Time Format you selected.

Set Date and Date Format



Note: The date and date format you configure display on the phone's idle screen.

1. Press **Options** on the phone to enter the Options List.
2. Select **Preferences**.
3. Select **Time and Date**.
4. Select **Set Date**.

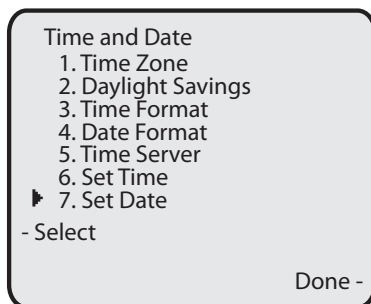

5. Using the keys on the keypad, enter a date on the IP phone. Use the **Backspace** softkey to move back a space and delete a character.

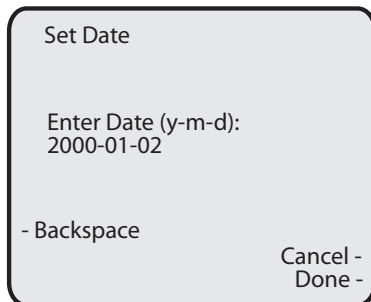

6. Press **Done** to save the setting.

7. Select **Date Format**.

8. Select a date format from the list of options. Default is **Sun Jan 2**. Valid values are:

- Sun Jan 2 (Default)
- 2-Jan-00
- 2000 01 02
- 02/01/2000
- 02/01/00
- 02-01-00
- 01/.02/00
- Jan 2
- 2 Jan 2000
- Sun 2 Jan
- 2 Jan
- 02.01.2000

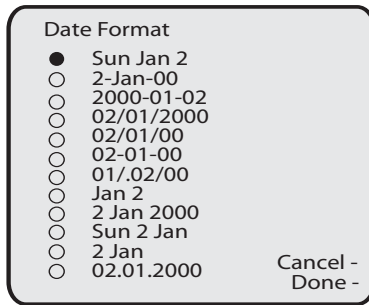

9. Press **Done** to save the Date Format.

Set Time Zone

- 1. Select Preferences.
- 2. Select Time and Date.
- 3. Select Time Zone.

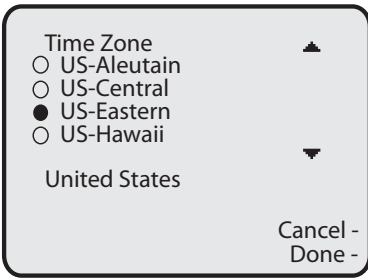

A list of Time Zones display for different areas of the world.

- 4. Select a Time Zone that applies to your area. The default Time Zone is **US-Eastern**.



Note: For a list of the Time Zones values available on the IP Phone, see "Appendix A - Time Zone Codes".

- 5. Press **Done** to save the Time Zone setting.

Daylight Savings Time

- 1. Select Preferences.
- 2. Select Time and Date.

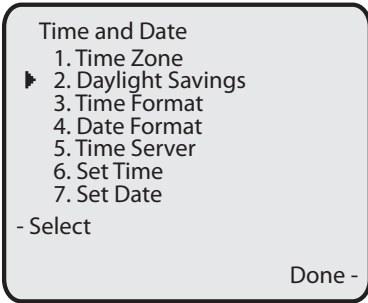

3. Select Daylight Saving.

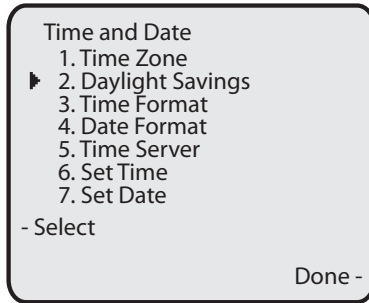

4. Select a Daylight Saving time from the list of options. Default is **Automatic**. Valid values are:

- OFF
- 30 min summertime
- 1h summertime
- Automatic (Default)

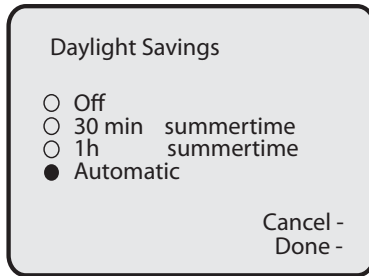

5. Press **Done** to save the Daylight Savings value you selected.

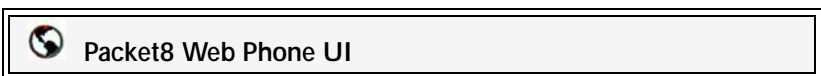

1. Click on **Basic Settings->Preferences->Time and Date Setting**.

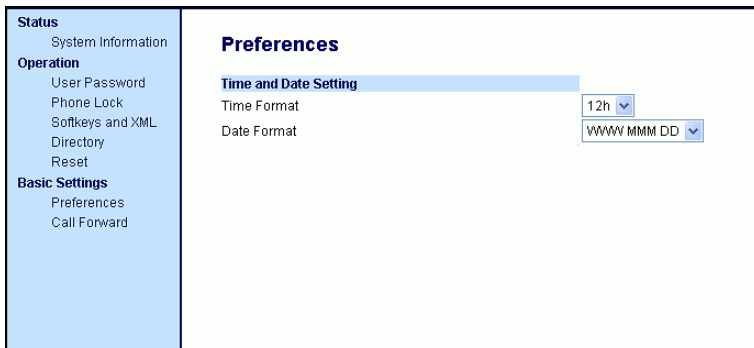

- In the **Time Format** field, select the time format you want to use on your phone. Valid values are:
 - 12h** (12 hour format) (default)
 - 24h** (24 hour format)



Note: The time and time format you configure display on the phone's idle screen.

- In the **Date Format** field, select the date format you want to use on your phone. Default is **WWW MMM DD**. Valid values are:
 - WWW MMM DD** (default)
 - DD-MMM-YY**
 - YYYY-MM-DD**
 - DD/MM/YYYY**
 - DD/MM/YY**
 - DD-MM-YY**
 - MM/DD/YY**
 - MMM DD**
 - DD MMM YYYY**
 - WWW DD MMM**
 - DD MMM**
 - DD.MM.YYYY**



Note: The date and date format you configure display on the phone's idle screen.

- Click  to save your settings.

User Password

This category allows you to change the user password for your phone. Changing your password ensures that only you can alter your phone settings, and helps keep your system secure. You can change your user password using the IP Phone UI or the Packet8 Web Phone UI.

If you change the password	then you need to:
Using the IP Phone UI,	Use that new password to log into the Packet8 Web Phone UI.
Using the Packet8 Web Phone UI,	Use that new password when changing the user password via the IP Phone UI.



Note: Valid values when creating or changing a password are 0 to 4294967295 (integers only; symbols and alpha characters are not allowed). Default password is an empty string "" (field is blank).

Setting a User Password



Note: If required, use the following keys while entering a password:

- **Backspace** softkey moves cursor back a space and deletes characters
- **Clear** softkey clears entire field of all characters
- **Quit** softkey cancels the password changing process without saving.

1. Press  on the phone to enter the Options List.
2. Select **User Password** and press **Select**.
3. At the **Current Password:** prompt, enter the current user password and press **Enter**.
4. At the **New Password:** prompt, enter the new user password and press **Enter**.
5. At the **Re-enter Password:** prompt, re-enter the new user password and press **Enter**. A message, **Password Changed** displays on the screen.



Packet8 Web Phone UI

1. Click on **Operation->User Password**.

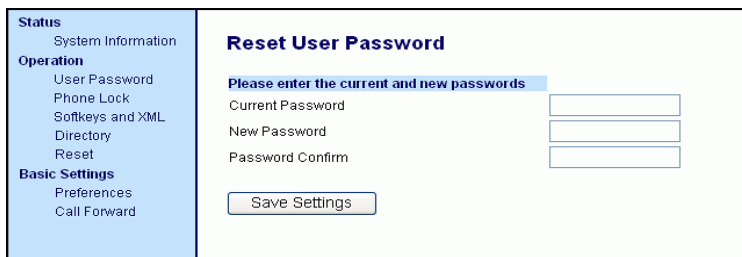

Status System Information	Reset User Password
Operation User Password Phone Lock Softkeys and XML Directory Reset	Please enter the current and new passwords
Basic Settings Preferences Call Forward	Current Password <input type="text"/>
	New Password <input type="text"/>
	Password Confirm <input type="text"/>
	<input type="button" value="Save Settings"/>

2. In the **Current Password** field, enter the current user password.



Note: By default, the user name is "user" (all lowercase) and the password field is left blank.

3. In the **New Password** field, enter the new user password.
4. In the **Password Confirm** field, enter the new user password again.
5. Click  to save your changes.

Resetting a User Password

If you forget your password, you can reset it and enter a new password. The reset user password feature resets the password to the factory default which is blank (no password).

You can reset a user password using the Packet8 Web Phone UI only.



Note: Valid values when creating or changing a password are 0 to 4294967295 (integers only; symbols and alpha characters are not allowed). Default password is an empty string "" (field is blank).

Reset a User Password

Use the following procedure to reset a user password.



Packet8 Web Phone UI

1. Click on Operation->Phone Lock.

Status System Information Operation User Password Phone Lock Softkeys and XML Directory Reset Expansion Modules Basic Settings Preferences Call Forward	Phone Lock Lock or unlock the phone <input type="text"/> Emergency Dial Plan <input type="text" value="911"/> Lock the phone? <input type="button" value="Lock"/> Reset User Password <input type="button" value="Reset"/> <input type="button" value="Save Settings"/>
---------------------------------------------------------------------------------------------------------------------------------------------------------------------------------------------------------------	-----------------------------------------------------------------------------------------------------------------------------------------------------------------------------------------------------------------------------------------------------------------------------------------------

2. In the "Reset User Password" field, click . The following screen displays.

Status System Information Operation User Password Phone Lock Softkeys and XML Directory Reset Expansion Modules Basic Settings Preferences Call Forward	Reset User Password Please enter the current and new passwords Current Password <input type="text"/> New Password <input type="text"/> Password Confirm <input type="text"/> <input type="button" value="Save Settings"/>
---------------------------------------------------------------------------------------------------------------------------------------------------------------------------------------------------------------	-------------------------------------------------------------------------------------------------------------------------------------------------------------------------------------------------------------------------------------------------

3. Leave the **Current Password** field blank.
4. Enter new password in the **New Password** field.
5. Re-enter your new password in the **Password Confirm** field.
6. Click to save your settings.

Restarting your phone

You may want to restart your phone to check for updates on the server. You may occasionally need to restart your phone to set changes or updates to your phone or network settings. You may also need to restart your phone if you have been asked to do so by your System Administrator, or should you experience any unexpected behavior.



IP Phone UI

1. Press the  button on the phone to enter the Options List.
2. Select **Restart Phone**.
3. When the prompt, **Are you sure you wish to restart the phone?** appears, press the **Restart** softkey. If you do not wish to restart your phone, press **Cancel**.



Note: Your phone is out of service temporarily during the restart and downloading process.



Packet8 Web Phone UI

1. Click on **Operation->Reset**.



2. Click .
3. Click **OK** at the confirmation prompt.

Phone Lock

You can lock your phone to prevent the phone from being used or configured. You can lock the phone using any of the following:

- At the path **Options**->**Phone Lock** on the IP Phone UI.
- At the path **Operations**->**Phone Lock** on the Packet8 Web Phone UI.
- At a configured key on the phone. For more information about configuring a Lock/Unlock key on your phone, see "[Phone Lock Key](#)" on [page 73](#).

In the Packet8 Web Phone UI, the **Operation**->**Phone Lock** path also allows you to perform the following:

- Reset a user password. Clicking on the **Reset** button in the **Reset User Password** field displays a screen that allows you to enter and save a new user password.
- Set an emergency dial plan. The emergency dial plan is 911.

The following procedures describe locking the phone, setting an emergency dial plan, and resetting the user password.

Locking/Unlocking a Phone

Use the following procedures to lock an IP phone and prevent it from being used or configured.



IP Phone UI

Lock the Phone

1. Press  on the phone to enter the Options List.
2. Select **Phone Lock** and press **Select**.
3. At the **Lock the phone?** prompt, press **Lock**. The message **Phone is locked** displays.

Unlock the Phone

1. Press  on the phone to enter the Options List.
2. At the prompt, to **unlock the phone**, enter your user password and press **Enter**. The phone unlocks.



1. Click on **Operation->Phone Lock**.

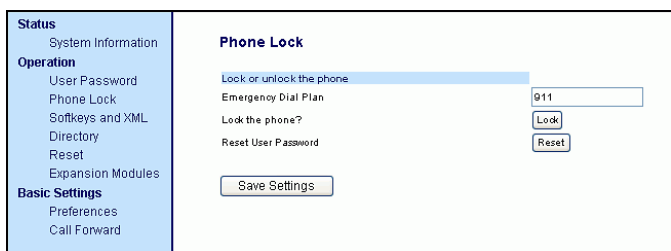

Lock the Phone

2. In the **Lock the Phone?** field, click **Lock**. The phone locks and displays the following message: **Phone is locked**.

Unlock the Phone

3. Click on **Operation->Phone Lock**.
4. In the **Unlock the Phone?** field, click **Unlock**. The phone unlocks and displays the following message: **Phone is unlocked**.

Defining an Emergency Dial Plan

Public telephone networks in countries around the world have a single emergency telephone number (emergency services number), that allows a caller to contact local emergency services for assistance when required. The emergency telephone number may differ from country to country. It is typically a three-digit number so that it can be easily remembered and dialed quickly. Some countries have a different emergency number for each of the different emergency services.

You can specify the digits to dial on the IP phone for contacting emergency services. Once you specify the emergency number(s) on the phone, you can dial those numbers directly on the dialpad when required and the phone automatically dials to those emergency services. The following table describes the default emergency numbers on the IP phones.

Emergency Number	Description
*9911	A United States emergency number

* When defining an Emergency number, you must insert a 9 before the number. You can set the emergency dial plan using the Packet8 Web Phone UI.

Define an Emergency Dial Plan

Use the following procedure to specify the numbers to use on your phone for dialing emergency services in your area.



Packet8 Web Phone UI

1. Click on **Operation->Phone Lock**.

<p>Status System Information</p> <p>Operation User Password Phone Lock Softkeys and XML Directory Reset Expansion Modules</p> <p>Basic Settings Preferences Call Forward</p>	<p>Phone Lock</p> <p>Lock or unlock the phone</p> <p>Emergency Dial Plan <input type="text" value="911"/></p> <p>Lock the phone? <input type="button" value="Lock"/></p> <p>Reset User Password <input type="button" value="Reset"/></p> <p><input type="button" value="Save Settings"/></p>
---------------------------------------------------------------------------------------------------------------------------------------------------------------------------------------------------------------------------------------	-----------------------------------------------------------------------------------------------------------------------------------------------------------------------------------------------------------------------------------------------------------------------------------------------------

2. In the **Emergency Dial Plan** field, enter the 3-digit number used in your local area to contact emergency services. For multiple numbers, enter a “|” between each emergency number. For example:

9911 | 91 (Area Code)(Digit #)

Default for this field is 911.

3. Click to save the emergency dial plan to your phone.

Reference

For more advanced options, see "[Additional Features](#)" on [page 138](#).

Line Keys and Softkeys

This section describes the Multiple Line/Call Appearance Keys (L1, L2, L3, and L4) located on the bottom-right of the phone, and the customizable softkeys located at the top and bottom of the phone screen.

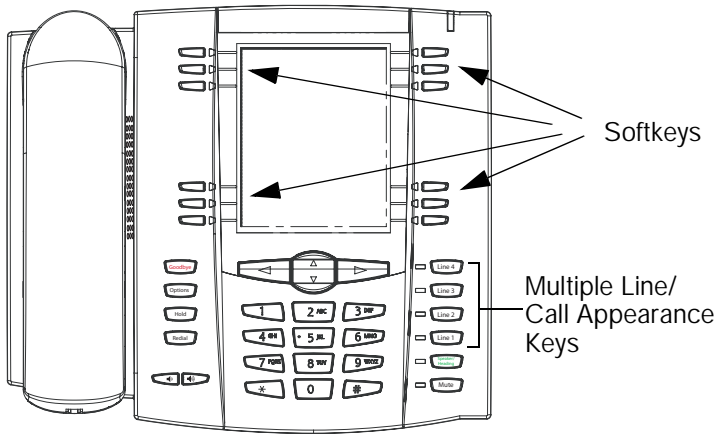

Multiple Line and Call Appearances

The 6757i CT has 4 hard line/call appearance buttons each with a corresponding status light.

These line/call appearance buttons and lights can represent physical lines, calls for your extension or calls from a group that your extension is part of. By pressing a line/call appearance button, you connect to the line or a call it represents. The line/call appearance light indicates the status of that line or call. When the phone is taken off-hook, the phone automatically selects a line for you.

Line/Call Appearance Light Behavior	Line/Call Appearance Status
Off	Idle line or no call activity
Light flashes quickly	Ringing
Light is solid	Connected
Light flashes slowly	Hold

When you have more than one call, you can use the left and right navigation buttons ◀ and ▶ to scroll left and right to the different call information status. Icons ◀ and ▶ appear if there is call information either left, right or both sides of the current information status you are viewing.

The display shows which line the call information is referring to (L1, L2, L3 or L4), the Caller ID information (name and number, if available), the call status (Connected, Ring, Hold, etc.) and the timer specific to that call.

Softkeys

Your 6757i CT has 12 multi-functional softkeys:

- **6 Top Keys:** static softkeys (up to 10 programmable functions)
- **6 Bottom Keys:** state-based softkeys (up to 20 programmable functions).

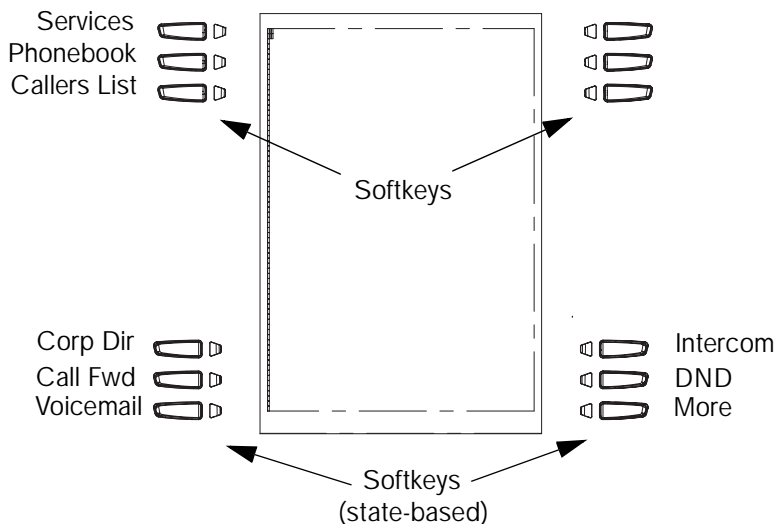

Note: If a 536EM or 560EM Expansion Module is attached to the phone, you can configure up to an additional 36 softkeys on each 536EM Expansion Module and up to 60 softkeys on each 560EM Expansion Module. (The 6757i CT IP Phone allows up to 3 expansion modules on each phone). For more information about expansion modules, see "Model 536EM and 560EM Expansion Modules" on page 153.

You can use the Packet8 Web Phone UI only, to configure key functions. The following table lists the functions you can set on the softkeys and provides a description for each function.

Key Function	Description
None	Indicates no setting for the key.
Line	Indicates key is configured for line use.
Speeddial	Indicates key is configured for speeddial use. Available on 536EM also. You can also configure a prefix for a speeddial number.
Do Not Disturb (DND)	Indicates key is configured for "Do Not Disturb" on the phone.

Key Function	Description
Busy Lamp Field (BLF)	Indicates key is configured for Busy Lamp Field (BLF) use. A user can dial out on a BLF configured key. (Maximum of 50 BLFs allowed on 536EM and 560EM Expansion Modules.)
Flash	Indicates the key is set to generate a flash event when it is pressed. The IP phone generates flash events only when a call is connected and there is an active RTP stream (for example, when the call is not on hold.)
Services (Top Key 1 by Default)	Indicates the key is configured to access the Services Menu. By default, the Services Menu displays the following options on the phone: Directory Callers List Voicemail Your Administrator can configure XML Services to add to this Services Menu. Contact your System Administrator for more information.
Directory (Top Key 2 by Default)	Indicates the key is configured to access the Phonebook.
Callers List (Top Key 3 by Default)	Indicates the key is configured to access the Callers List.
Intercom (Top Key 4 by Default)	Indicates the key is configured to be used for Intercom calls.
Phone Lock	Indicates key is configured as a phone lock key, allowing you to press this key to lock/unlock the phone.
Empty	Indicates key is configured as an empty key.

Keys can also be set up to quickly access features such as Do Not Disturb (DND) or Voicemail.

State-Based Softkeys (Bottom Keys only)

On the 6757i CT bottom softkeys, you can configure a specific state to display when a softkey is being used.

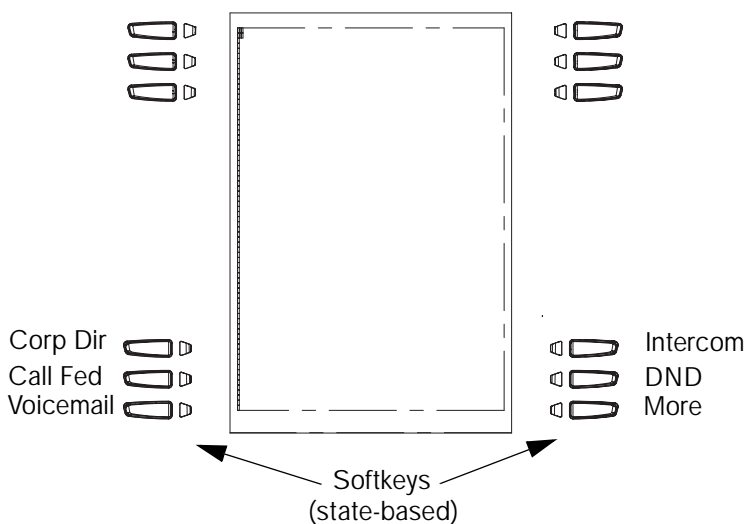

The following table describes the states available to configure for the softkeys.

State	Description
Idle	The phone is not being used.
Connected	The current line is in an active call (or the call is on hold).
Incoming	The phone is ringing.
Outgoing	The user is dialing a number, or the far-end is ringing.
Busy	The current line is busy because the line is in use or the line is set as "Do Not Disturb".

The following table identifies the applicable default states for each softkey type on the IP phone.

Softkey Type	Default States
None	All states disabled.
Line	Idle, Connected, Incoming, Outgoing, Busy
Speeddial	Idle, Connected, Incoming, Outgoing, Busy
DND	Idle, Connected, Incoming, Outgoing, Busy
BLF	Idle, Connected, Incoming, Outgoing, Busy
BLF List	Idle, Connected, Incoming, Outgoing, Busy

Softkey Type	Default States
Auto Call Distribution (ACD)	Idle
Directed Call Pickup (DCP)	Idle, Connected, Incoming, Outgoing, Busy
Group Call Pickup (GCP)	
XML	Idle, Connected, Incoming, Outgoing, Busy
Flash	All States Disabled.
Sprecode	Connected
Park	Connected
Pickup	Idle, Outgoing
Last Call Return	Idle, Connected, Incoming, Outgoing, Busy
Services	Idle, Connected, Incoming, Outgoing, Busy
Directory	Idle, Connected, Incoming, Outgoing, Busy
Callers List	Idle, Connected, Incoming, Outgoing, Busy
Intercom	Idle, Connected, Incoming, Outgoing, Busy
Phone Lock	All States Disabled.

In the Packet8 Web Phone UI, the operational states for each softkey display enabled. To **disable** a state, you uncheck the box for that state.

Key Display Behavior

On the 6757i CT IP Phone, you can configure up to 20 functions on the bottom softkeys. If you have no softkeys configured on the IP Phone, and you assign softkey functions to higher number keys in the Packet8 Web Phone UI, the key functions automatically appear in the first available position on the LCD display.

For example, if softkeys 1 through 20 are set to **None**, and you set softkey 12 as the following:

Type: speeddial

Label: LAB

Value: 3456

after saving the settings, the "LAB" label actually appears in position 1 of the LCD .

A softkey function of **none** does not display on the idle screen at all.

The following illustrations show the configuration of Key 12 and how that key displays on the phone.

Key	Type	Label	Value	Line	Idle	Connected	Incoming	Outgoing	Busy
1	None			1	<input checked="" type="checkbox"/>	<input checked="" type="checkbox"/>	<input checked="" type="checkbox"/>	<input checked="" type="checkbox"/>	<input checked="" type="checkbox"/>
2	None			1	<input checked="" type="checkbox"/>	<input checked="" type="checkbox"/>	<input checked="" type="checkbox"/>	<input checked="" type="checkbox"/>	<input checked="" type="checkbox"/>
3	Name			1	<input checked="" type="checkbox"/>	<input checked="" type="checkbox"/>	<input checked="" type="checkbox"/>	<input checked="" type="checkbox"/>	<input checked="" type="checkbox"/>
4	Name			1	<input checked="" type="checkbox"/>	<input checked="" type="checkbox"/>	<input checked="" type="checkbox"/>	<input checked="" type="checkbox"/>	<input checked="" type="checkbox"/>
5	None			1	<input checked="" type="checkbox"/>	<input checked="" type="checkbox"/>	<input checked="" type="checkbox"/>	<input checked="" type="checkbox"/>	<input checked="" type="checkbox"/>
6	None			1	<input checked="" type="checkbox"/>	<input checked="" type="checkbox"/>	<input checked="" type="checkbox"/>	<input checked="" type="checkbox"/>	<input checked="" type="checkbox"/>
7	None			1	<input checked="" type="checkbox"/>	<input checked="" type="checkbox"/>	<input checked="" type="checkbox"/>	<input checked="" type="checkbox"/>	<input checked="" type="checkbox"/>
8	Name			1	<input checked="" type="checkbox"/>	<input checked="" type="checkbox"/>	<input checked="" type="checkbox"/>	<input checked="" type="checkbox"/>	<input checked="" type="checkbox"/>
9	None			1	<input checked="" type="checkbox"/>	<input checked="" type="checkbox"/>	<input checked="" type="checkbox"/>	<input checked="" type="checkbox"/>	<input checked="" type="checkbox"/>
10	None			1	<input checked="" type="checkbox"/>	<input checked="" type="checkbox"/>	<input checked="" type="checkbox"/>	<input checked="" type="checkbox"/>	<input checked="" type="checkbox"/>
11	None			1	<input checked="" type="checkbox"/>	<input checked="" type="checkbox"/>	<input checked="" type="checkbox"/>	<input checked="" type="checkbox"/>	<input checked="" type="checkbox"/>
12	Speeddial	LAB	3456	1	<input checked="" type="checkbox"/>	<input checked="" type="checkbox"/>	<input checked="" type="checkbox"/>	<input checked="" type="checkbox"/>	<input checked="" type="checkbox"/>
13	None			1	<input checked="" type="checkbox"/>	<input checked="" type="checkbox"/>	<input checked="" type="checkbox"/>	<input checked="" type="checkbox"/>	<input checked="" type="checkbox"/>
14	None			1	<input checked="" type="checkbox"/>	<input checked="" type="checkbox"/>	<input checked="" type="checkbox"/>	<input checked="" type="checkbox"/>	<input checked="" type="checkbox"/>
15	None			1	<input checked="" type="checkbox"/>	<input checked="" type="checkbox"/>	<input checked="" type="checkbox"/>	<input checked="" type="checkbox"/>	<input checked="" type="checkbox"/>
16	None			1	<input checked="" type="checkbox"/>	<input checked="" type="checkbox"/>	<input checked="" type="checkbox"/>	<input checked="" type="checkbox"/>	<input checked="" type="checkbox"/>
17	Name			1	<input checked="" type="checkbox"/>	<input checked="" type="checkbox"/>	<input checked="" type="checkbox"/>	<input checked="" type="checkbox"/>	<input checked="" type="checkbox"/>
18	Name			1	<input checked="" type="checkbox"/>	<input checked="" type="checkbox"/>	<input checked="" type="checkbox"/>	<input checked="" type="checkbox"/>	<input checked="" type="checkbox"/>
19	None			1	<input checked="" type="checkbox"/>	<input checked="" type="checkbox"/>	<input checked="" type="checkbox"/>	<input checked="" type="checkbox"/>	<input checked="" type="checkbox"/>
20	None			1	<input checked="" type="checkbox"/>	<input checked="" type="checkbox"/>	<input checked="" type="checkbox"/>	<input checked="" type="checkbox"/>	<input checked="" type="checkbox"/>

Key 12 configured as a speeddial

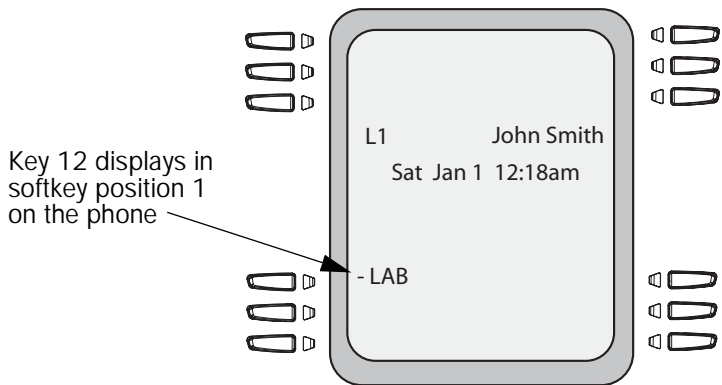



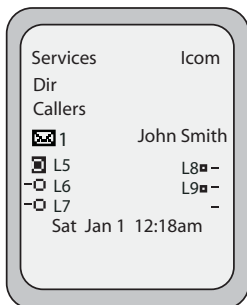

Line Key

You can set a softkey to act as a line/call appearance key on the 6757i CT. This key acts as a line that behaves the same as a hard line key (L1, L2, L3, and L4). For more information about the behavior of line keys, see ["Multiple Line and Call Appearances"](#) on [page 47](#).

If you configure line keys for the softkeys, the status of the lines/call appearance keys appear on the phone's display as shown in the following image.



Icons next to the softkeys on the phone's display indicate the status for that line or call. The following table provides a description for each icon.

Softkey Line/Call Appearance Lights			
Activity	Light	Icon	Definition
Idle	Solid		There is no call activity for the line/call appearance softkey.
Connected	Solid		A call is connected to your phone on this line/call appearance softkey. The equivalent on a line/call appearance hard key is a solid green light.
Ringing	Flashing		A call is ringing at your phone on this line/call appearance softkey. The equivalent on a line/call appearance hard key is a fast flashing green light.
On Hold	Flashing		A call is on hold on your phone on this line/call appearance softkey. The equivalent on a line/call appearance hard key is a slow flashing green light.

Depending on how the phone has been configured, the maximum number of total line/call appearances that can be configured is 9 (4 line/call appearance hard keys plus 5 softkeys). If all line/call appearances have been set up between two different numbers, a total of 8 lines can be configured.

This means that when all line/call appearances are in use, 1 call is connected while the rest are on hold. No further outgoing or incoming calls can be made until one of the line/call appearances becomes available.

In active states, such as ringing, conference, connected, etc., all softkeys disappear except softkeys that have been set up as line/call appearances, and any context dependent softkeys required for the active state, such as the **Drop** softkey in the connected state. Typically, context dependent softkeys appear in the top left position and all line/call appearance softkeys appear in the remaining positions.



Note: In some situations, such as during a conference call, the line/call appearance softkeys may overwrite some of the context dependent softkeys. In this case, instead of the **Previous** and **Next** softkeys, up or down icons, **▲ ▼** appear on the display. By using the **▲ ▼** navigation keys, you can access the same functionality as the **Previous** and **Next** softkeys.

You use the Packet8 Web Phone UI to set a softkey as a line.

Setting a Line Key

You can set a key as an additional line on the 6757i CT. The key acts as a line that behaves the same as a hard line key. For more information about the behavior of line keys, see ["Multiple Line and Call Appearances"](#) on [page 47](#).

You use the Packet8 Web Phone UI to set a key as a line.



Packet8 Web Phone UI

Use the following procedure to set a key to function as a line.

1. Click on **Operation->Softkeys and XML**.
or
Click on **Operation->Expansion Module <N>**.

Softkeys Configuration

Bottom Keys | Top Keys

Key	Type	Label	Value	Line	Idle	Connected	Incoming	Outgoing	Busy
1	Speedial	labtest	1111	2	<input checked="" type="checkbox"/>	<input checked="" type="checkbox"/>	<input checked="" type="checkbox"/>	<input checked="" type="checkbox"/>	<input checked="" type="checkbox"/>
2	Speedial	Portal		1	<input checked="" type="checkbox"/>	<input checked="" type="checkbox"/>	<input checked="" type="checkbox"/>	<input checked="" type="checkbox"/>	<input checked="" type="checkbox"/>
3	Speedial	Speed Dial	1111	1	<input checked="" type="checkbox"/>	<input checked="" type="checkbox"/>	<input checked="" type="checkbox"/>	<input checked="" type="checkbox"/>	<input checked="" type="checkbox"/>
4	Speedial	Call Return	*69	1	<input checked="" type="checkbox"/>	<input checked="" type="checkbox"/>	<input checked="" type="checkbox"/>	<input checked="" type="checkbox"/>	<input checked="" type="checkbox"/>
5	Speedial	Pickup	*90	1	<input checked="" type="checkbox"/>	<input checked="" type="checkbox"/>	<input checked="" type="checkbox"/>	<input checked="" type="checkbox"/>	<input checked="" type="checkbox"/>
6	Speedial	CallFwdOn	*72	1	<input checked="" type="checkbox"/>	<input checked="" type="checkbox"/>	<input checked="" type="checkbox"/>	<input checked="" type="checkbox"/>	<input checked="" type="checkbox"/>
7	Speedial	CallFwdOff	*73	1	<input checked="" type="checkbox"/>	<input checked="" type="checkbox"/>	<input checked="" type="checkbox"/>	<input checked="" type="checkbox"/>	<input checked="" type="checkbox"/>
8	Speedial	DND On	*78	1	<input checked="" type="checkbox"/>	<input checked="" type="checkbox"/>	<input checked="" type="checkbox"/>	<input checked="" type="checkbox"/>	<input checked="" type="checkbox"/>
9	Speedial	DND Off	*79	1	<input checked="" type="checkbox"/>	<input checked="" type="checkbox"/>	<input checked="" type="checkbox"/>	<input checked="" type="checkbox"/>	<input checked="" type="checkbox"/>
10	Speedial	CLIDBlock	*07	1	<input checked="" type="checkbox"/>	<input checked="" type="checkbox"/>	<input checked="" type="checkbox"/>	<input checked="" type="checkbox"/>	<input checked="" type="checkbox"/>
11	Speedial	Trace	*07	1	<input checked="" type="checkbox"/>	<input checked="" type="checkbox"/>	<input checked="" type="checkbox"/>	<input checked="" type="checkbox"/>	<input checked="" type="checkbox"/>
12	Speedial	Clear MMR	*99	1	<input checked="" type="checkbox"/>	<input checked="" type="checkbox"/>	<input checked="" type="checkbox"/>	<input checked="" type="checkbox"/>	<input checked="" type="checkbox"/>
13	Speedial	Cancel CW	*70	1	<input checked="" type="checkbox"/>	<input checked="" type="checkbox"/>	<input checked="" type="checkbox"/>	<input checked="" type="checkbox"/>	<input checked="" type="checkbox"/>
14	Speedial	Unpak	*88	1	<input checked="" type="checkbox"/>	<input checked="" type="checkbox"/>	<input checked="" type="checkbox"/>	<input checked="" type="checkbox"/>	<input checked="" type="checkbox"/>
15	None			1	<input type="checkbox"/>	<input checked="" type="checkbox"/>	<input checked="" type="checkbox"/>	<input checked="" type="checkbox"/>	<input checked="" type="checkbox"/>
16	None			1	<input type="checkbox"/>	<input checked="" type="checkbox"/>	<input checked="" type="checkbox"/>	<input checked="" type="checkbox"/>	<input checked="" type="checkbox"/>
17	None			1	<input type="checkbox"/>	<input checked="" type="checkbox"/>	<input checked="" type="checkbox"/>	<input checked="" type="checkbox"/>	<input checked="" type="checkbox"/>
18	None			1	<input type="checkbox"/>	<input checked="" type="checkbox"/>	<input checked="" type="checkbox"/>	<input checked="" type="checkbox"/>	<input checked="" type="checkbox"/>
19	None			1	<input type="checkbox"/>	<input checked="" type="checkbox"/>	<input checked="" type="checkbox"/>	<input checked="" type="checkbox"/>	<input checked="" type="checkbox"/>
20	None			1	<input type="checkbox"/>	<input checked="" type="checkbox"/>	<input checked="" type="checkbox"/>	<input checked="" type="checkbox"/>	<input checked="" type="checkbox"/>

Save Settings

2. Click on the **Bottom Keys** tab or the **Top Keys** tab.
3. Select from **"Key 1"** through **"Key 20"** on the bottom tab or select from **"Key 1"** through **"Key 10"** on the top tab.
4. In the **Type** field, select **Line** to apply to the softkey.
5. In the **Label** field, enter a label to apply to this softkey.
6. In the **Line** field, select a line to apply to this softkey. Valid values are **5 through 9**.
7. If configuring a softkey on the Bottom Keys, in the state fields, check (**enable**) or uncheck (**disable**) the states you want to apply to this softkey.
8. Click **Save Settings** to save your changes.

Speeddial Key

The normal function of the speeddial option allows you to dial a number quickly by pressing a key configured for speeddialing. You can program the keys on the 6757i CT to speeddial outside numbers, dial directly to another person's line or extension, or set up to quickly access features such as Do Not Disturb (DND), Voicemail.

The speeddial function can be set using the IP Phone UI or the Packet8 Web Phone UI.



Note: You can use a speeddial key while on an active call by placing the active call on hold first, and then pressing the speeddial key.

Speeddial Prefix

The speeddial feature also allows you to specify a preset string of numbers followed by a "+" that the phone dials automatically after pressing the speeddial key. You can use this feature for numbers that contain long prefixes.

For example, if you had the following speeddial configuration in the Packet8 Web Phone UI:

Key 1

Type=speeddial

Label=Europe Office

Value=1234567+

Line=2

then, after you press **key 1** on the phone, the prefix number displays on the phone screen. The phone proceeds to dial the prefix number automatically and pauses for you to enter the remaining phone number using the keypad on the phone.

You can save up to 30 speeddial numbers on the 6757i CT.

Use the following procedures to set speeddial on the 6757i CT IP phone.



IP Phone UI

Pressing and holding down a softkey on the phone initiates a speeddial feature.



Note: When creating a speeddial key from the IP Phone UI, you must select a softkey that has no preassigned function (key must be set to **None** or **Empty**.)

1. Press a softkey for 3 seconds. The screen displays the following:

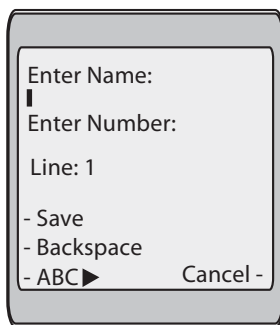

Note: You can press the **Cancel** softkey at anytime during the speeddial programming to cancel and not save the speeddial information.

2. In the **Enter Name:** field, enter a name to apply to the speeddial key. Use the keypad keys to enter the name. Continue to press the keypad keys to access the next letter for that key (i.e. press **2** three times to access **C**). Press **>** to move to the next space, or wait for the cursor to automatically advance to the next position. To insert a space between letters, press **>**. To backspace and erase a mistake, press the **Backspace** softkey.



Note: The phone automatically uses an uppercase letter for the first letter of each word and a lowercase letter for all subsequent letters in the word. If necessary, use the "**ABC 4**" softkey to specify uppercase letters or lowercase letters when entering the name.

You can enter up to 16 letters in the **Enter Name:** field.
Press the **▼** key to move to the next field.

3. In the **Enter Number:** field, enter a number for the speeddial key using the key-pad keys. You can enter up to 16 numbers in the **Enter Number:** field

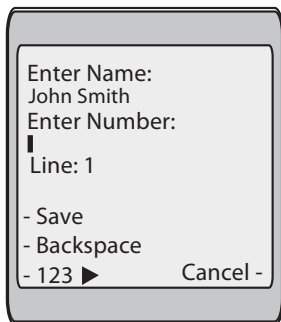

Note: When in the **Enter Number:** field, the phone automatically switches to the numbers softkey.

Press the ▼ key to move to the next field.

4. In the **Line:** field, select a line to apply to the speeddial key.

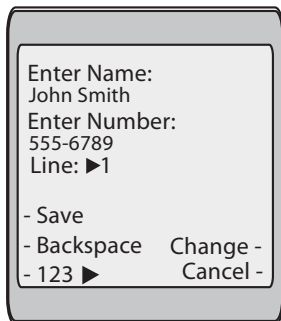

This is the line that the phone opens to dial the number after you press the speeddial key. By default, the phone uses Line 1 for the speeddial key. If you want to use a different line, press the **Change** softkey, or press the ► key to select another line.

5. Press the **Save** softkey to save the speeddial information to the speeddial key you selected.



Note: To delete or remove a softkey from the phone, you must access the phone's configuration using the Packet8 Web Phone UI and delete the speeddial information.



Use the following procedure to set a key to function as a speeddial.

1. Click on **Operation->Softkeys and XML**.
or
Click on **Operation->Expansion Module <N>**.

Key	Type	Label	Value	Line	Idle	Connected	Incoming	Outgoing	Busy
1	Speeddial	labtest	1111	2	<input checked="" type="checkbox"/>	<input checked="" type="checkbox"/>	<input checked="" type="checkbox"/>	<input checked="" type="checkbox"/>	<input checked="" type="checkbox"/>
2	Speeddial	Portal		1	<input checked="" type="checkbox"/>	<input checked="" type="checkbox"/>	<input checked="" type="checkbox"/>	<input checked="" type="checkbox"/>	<input checked="" type="checkbox"/>
3	Speeddial	Speed Dial	1111	1	<input checked="" type="checkbox"/>	<input checked="" type="checkbox"/>	<input checked="" type="checkbox"/>	<input checked="" type="checkbox"/>	<input checked="" type="checkbox"/>
4	Speeddial	Call Return	*69	1	<input checked="" type="checkbox"/>	<input checked="" type="checkbox"/>	<input checked="" type="checkbox"/>	<input checked="" type="checkbox"/>	<input checked="" type="checkbox"/>
5	Speeddial	Pickup	*08	1	<input checked="" type="checkbox"/>	<input checked="" type="checkbox"/>	<input checked="" type="checkbox"/>	<input checked="" type="checkbox"/>	<input checked="" type="checkbox"/>
6	Speeddial	CallForward	*72	1	<input checked="" type="checkbox"/>	<input checked="" type="checkbox"/>	<input checked="" type="checkbox"/>	<input checked="" type="checkbox"/>	<input checked="" type="checkbox"/>
7	Speeddial	CallForward	*73	1	<input checked="" type="checkbox"/>	<input checked="" type="checkbox"/>	<input checked="" type="checkbox"/>	<input checked="" type="checkbox"/>	<input checked="" type="checkbox"/>
8	Speeddial	DND On	*78	1	<input checked="" type="checkbox"/>	<input checked="" type="checkbox"/>	<input checked="" type="checkbox"/>	<input checked="" type="checkbox"/>	<input checked="" type="checkbox"/>
9	Speeddial	DND Off	*79	1	<input checked="" type="checkbox"/>	<input checked="" type="checkbox"/>	<input checked="" type="checkbox"/>	<input checked="" type="checkbox"/>	<input checked="" type="checkbox"/>
10	Speeddial	CLIRBlock	*97	1	<input checked="" type="checkbox"/>	<input checked="" type="checkbox"/>	<input checked="" type="checkbox"/>	<input checked="" type="checkbox"/>	<input checked="" type="checkbox"/>
11	Speeddial	Trace	*07	1	<input checked="" type="checkbox"/>	<input checked="" type="checkbox"/>	<input checked="" type="checkbox"/>	<input checked="" type="checkbox"/>	<input checked="" type="checkbox"/>
12	Speeddial	Clear MMR	*99	1	<input checked="" type="checkbox"/>	<input checked="" type="checkbox"/>	<input checked="" type="checkbox"/>	<input checked="" type="checkbox"/>	<input checked="" type="checkbox"/>
13	Speeddial	Cancel Call	*70	1	<input checked="" type="checkbox"/>	<input checked="" type="checkbox"/>	<input checked="" type="checkbox"/>	<input checked="" type="checkbox"/>	<input checked="" type="checkbox"/>
14	Speeddial	Unpark	*80	1	<input checked="" type="checkbox"/>	<input checked="" type="checkbox"/>	<input checked="" type="checkbox"/>	<input checked="" type="checkbox"/>	<input checked="" type="checkbox"/>
15	None			1	<input checked="" type="checkbox"/>	<input checked="" type="checkbox"/>	<input checked="" type="checkbox"/>	<input checked="" type="checkbox"/>	<input checked="" type="checkbox"/>
16	None			1	<input checked="" type="checkbox"/>	<input checked="" type="checkbox"/>	<input checked="" type="checkbox"/>	<input checked="" type="checkbox"/>	<input checked="" type="checkbox"/>
17	None			1	<input checked="" type="checkbox"/>	<input checked="" type="checkbox"/>	<input checked="" type="checkbox"/>	<input checked="" type="checkbox"/>	<input checked="" type="checkbox"/>
18	None			1	<input checked="" type="checkbox"/>	<input checked="" type="checkbox"/>	<input checked="" type="checkbox"/>	<input checked="" type="checkbox"/>	<input checked="" type="checkbox"/>
19	None			1	<input checked="" type="checkbox"/>	<input checked="" type="checkbox"/>	<input checked="" type="checkbox"/>	<input checked="" type="checkbox"/>	<input checked="" type="checkbox"/>
20	None			1	<input checked="" type="checkbox"/>	<input checked="" type="checkbox"/>	<input checked="" type="checkbox"/>	<input checked="" type="checkbox"/>	<input checked="" type="checkbox"/>

2. Click on the **Bottom Keys** tab or the **Top Keys** tab.
3. Select from "Key 1" through "Key 20" on the bottom tab or select from "Key 1" through "Key 10" on the top tab.
4. In the **Type** field, select **Speeddial** to apply to the softkey.
5. In the **Label** field, enter a label to apply to this softkey.
6. In the **Value** field, enter the phone number, extension, or speeddial prefix to apply to this key. If you enter a speeddial prefix, you must enter the "+" character at the end of the prefix number (for example, "123456+").
7. In the **Line** field, select a line to apply to this softkey. Valid values are **1 through 9**.
8. If configuring a softkey on the **Bottom Keys**, in the state fields, check (**enable**) or uncheck (**disable**) the states you want to apply to this softkey.
9. Click **Save Settings** to save your changes.

Do not Disturb (DND) Key

The IP phones have a feature you can enable called **Do not Disturb (DND)**. The DND function allows you to turn **Do not Disturb ON** and **OFF**.



Note: You can configure DND using the Packet8 Web Phone UI only.

If DND is ON, callers hear a busy signal or a message, depending on how your System Administrator set up the configuration server. The second line on the screen of the IP phone shows when DND is set.

If the phone shares a line with other phones, only the phone that has DND configured is affected.

You can set DND on the softkeys using the Packet8 Web Phone UI only. DND is not configurable from the IP phone UI.

Setting a Do Not Disturb (DND) Key



Packet8 Web Phone UI

Use the following procedure to set a key to function as **Do Not Disturb**.

1. Click on **Operation->Softkeys and XML** or Click on **Operation->Expansion Module <N>**.

Status		Softkeys Configuration									
System Information		Bottom Keys		Top Keys							
Key	Type	Label	Value	Line	Idle	Connected	Incoming	Outgoing	Busy		
1	Speedial	Interact	1111	2	<input checked="" type="checkbox"/>	<input checked="" type="checkbox"/>	<input checked="" type="checkbox"/>	<input checked="" type="checkbox"/>	<input checked="" type="checkbox"/>	<input checked="" type="checkbox"/>	
2	Speedial	Portal		1	<input checked="" type="checkbox"/>	<input checked="" type="checkbox"/>	<input checked="" type="checkbox"/>	<input checked="" type="checkbox"/>	<input checked="" type="checkbox"/>	<input checked="" type="checkbox"/>	
3	Speedial	Speedial	1111	1	<input checked="" type="checkbox"/>	<input checked="" type="checkbox"/>	<input checked="" type="checkbox"/>	<input checked="" type="checkbox"/>	<input checked="" type="checkbox"/>	<input checked="" type="checkbox"/>	
4	Speedial	Call Return	*60	1	<input checked="" type="checkbox"/>	<input checked="" type="checkbox"/>	<input checked="" type="checkbox"/>	<input checked="" type="checkbox"/>	<input checked="" type="checkbox"/>	<input checked="" type="checkbox"/>	
5	Speedial	Pickup	*68	1	<input checked="" type="checkbox"/>	<input checked="" type="checkbox"/>	<input checked="" type="checkbox"/>	<input checked="" type="checkbox"/>	<input checked="" type="checkbox"/>	<input checked="" type="checkbox"/>	
6	Speedial	CallFeedOn	*72	1	<input checked="" type="checkbox"/>	<input checked="" type="checkbox"/>	<input checked="" type="checkbox"/>	<input checked="" type="checkbox"/>	<input checked="" type="checkbox"/>	<input checked="" type="checkbox"/>	
7	Speedial	CallFeedOff	*73	1	<input checked="" type="checkbox"/>	<input checked="" type="checkbox"/>	<input checked="" type="checkbox"/>	<input checked="" type="checkbox"/>	<input checked="" type="checkbox"/>	<input checked="" type="checkbox"/>	
8	Speedial	DND On	*78	1	<input checked="" type="checkbox"/>	<input checked="" type="checkbox"/>	<input checked="" type="checkbox"/>	<input checked="" type="checkbox"/>	<input checked="" type="checkbox"/>	<input checked="" type="checkbox"/>	
9	Speedial	DND Off	*79	1	<input checked="" type="checkbox"/>	<input checked="" type="checkbox"/>	<input checked="" type="checkbox"/>	<input checked="" type="checkbox"/>	<input checked="" type="checkbox"/>	<input checked="" type="checkbox"/>	
10	Speedial	CLIOBlock	*87	1	<input checked="" type="checkbox"/>	<input checked="" type="checkbox"/>	<input checked="" type="checkbox"/>	<input checked="" type="checkbox"/>	<input checked="" type="checkbox"/>	<input checked="" type="checkbox"/>	
11	Speedial	Trace	*87	1	<input checked="" type="checkbox"/>	<input checked="" type="checkbox"/>	<input checked="" type="checkbox"/>	<input checked="" type="checkbox"/>	<input checked="" type="checkbox"/>	<input checked="" type="checkbox"/>	
12	Speedial	Clear MW	*99	1	<input checked="" type="checkbox"/>	<input checked="" type="checkbox"/>	<input checked="" type="checkbox"/>	<input checked="" type="checkbox"/>	<input checked="" type="checkbox"/>	<input checked="" type="checkbox"/>	
13	Speedial	Cancel CW	*70	1	<input checked="" type="checkbox"/>	<input checked="" type="checkbox"/>	<input checked="" type="checkbox"/>	<input checked="" type="checkbox"/>	<input checked="" type="checkbox"/>	<input checked="" type="checkbox"/>	
14	Speedial	Unpak	*80	1	<input checked="" type="checkbox"/>	<input checked="" type="checkbox"/>	<input checked="" type="checkbox"/>	<input checked="" type="checkbox"/>	<input checked="" type="checkbox"/>	<input checked="" type="checkbox"/>	
15	None			1	<input type="checkbox"/>	<input type="checkbox"/>	<input type="checkbox"/>	<input type="checkbox"/>	<input type="checkbox"/>	<input type="checkbox"/>	
16	None			1	<input type="checkbox"/>	<input type="checkbox"/>	<input type="checkbox"/>	<input type="checkbox"/>	<input type="checkbox"/>	<input type="checkbox"/>	
17	None			1	<input type="checkbox"/>	<input type="checkbox"/>	<input type="checkbox"/>	<input type="checkbox"/>	<input type="checkbox"/>	<input type="checkbox"/>	
18	None			1	<input type="checkbox"/>	<input type="checkbox"/>	<input type="checkbox"/>	<input type="checkbox"/>	<input type="checkbox"/>	<input type="checkbox"/>	
19	None			1	<input type="checkbox"/>	<input type="checkbox"/>	<input type="checkbox"/>	<input type="checkbox"/>	<input type="checkbox"/>	<input type="checkbox"/>	
20	None			1	<input type="checkbox"/>	<input type="checkbox"/>	<input type="checkbox"/>	<input type="checkbox"/>	<input type="checkbox"/>	<input type="checkbox"/>	

2. Click on the **Bottom Keys** tab or the **Top Keys** tab.
3. Select from "Key 1" through "Key 20" on the bottom tab or select from "Key 1" through "Key 10" on the top tab.
4. In the **Type** field, select **Do Not Disturb** to apply to the softkey.

- If configuring a softkey on the bottom keys, in the state fields, check (enable) or uncheck (disable) the states you want to apply to this softkey.
- Click to save your changes.

Setting a BLF Key



Packet8 Web Phone UI

- Click on Operation->Softkeys and XML.
or
Click on Operation->Expansion Module <N>.

Status

System Information

Operation

User Password

Phone Lock

Softkeys and XML

Directory

Reset

Basic Settings

Preferences

Call Forward

Softkeys Configuration

Bottom Keys
Top Keys

Key	Type	Label	Value	Line	Idle	Connected	Incoming	Outgoing	Busy
1	Speedial	labtest	1111	2	<input checked="" type="checkbox"/>	<input checked="" type="checkbox"/>	<input checked="" type="checkbox"/>	<input checked="" type="checkbox"/>	<input checked="" type="checkbox"/>
2	Speedial	Portal		1	<input checked="" type="checkbox"/>	<input checked="" type="checkbox"/>	<input checked="" type="checkbox"/>	<input checked="" type="checkbox"/>	<input checked="" type="checkbox"/>
3	Speedial	Speed Dial	1111	1	<input checked="" type="checkbox"/>	<input checked="" type="checkbox"/>	<input checked="" type="checkbox"/>	<input checked="" type="checkbox"/>	<input checked="" type="checkbox"/>
4	Speedial	Call Return	*69	1	<input checked="" type="checkbox"/>	<input checked="" type="checkbox"/>	<input checked="" type="checkbox"/>	<input checked="" type="checkbox"/>	<input checked="" type="checkbox"/>
5	Speedial	Pickup	*98	1	<input checked="" type="checkbox"/>	<input checked="" type="checkbox"/>	<input checked="" type="checkbox"/>	<input checked="" type="checkbox"/>	<input checked="" type="checkbox"/>
6	Speedial	CallFwdOn	*72	1	<input checked="" type="checkbox"/>	<input checked="" type="checkbox"/>	<input checked="" type="checkbox"/>	<input checked="" type="checkbox"/>	<input checked="" type="checkbox"/>
7	Speedial	CallFwdOff	*73	1	<input checked="" type="checkbox"/>	<input checked="" type="checkbox"/>	<input checked="" type="checkbox"/>	<input checked="" type="checkbox"/>	<input checked="" type="checkbox"/>
8	Speedial	DND On	*78	1	<input checked="" type="checkbox"/>	<input checked="" type="checkbox"/>	<input checked="" type="checkbox"/>	<input checked="" type="checkbox"/>	<input checked="" type="checkbox"/>
9	Speedial	DND Off	*79	1	<input checked="" type="checkbox"/>	<input checked="" type="checkbox"/>	<input checked="" type="checkbox"/>	<input checked="" type="checkbox"/>	<input checked="" type="checkbox"/>
10	Speedial	CLIDBlock	*07	1	<input checked="" type="checkbox"/>	<input checked="" type="checkbox"/>	<input checked="" type="checkbox"/>	<input checked="" type="checkbox"/>	<input checked="" type="checkbox"/>
11	Speedial	Trace	*07	1	<input checked="" type="checkbox"/>	<input checked="" type="checkbox"/>	<input checked="" type="checkbox"/>	<input checked="" type="checkbox"/>	<input checked="" type="checkbox"/>
12	Speedial	Clear MMR	*99	1	<input checked="" type="checkbox"/>	<input checked="" type="checkbox"/>	<input checked="" type="checkbox"/>	<input checked="" type="checkbox"/>	<input checked="" type="checkbox"/>
13	Speedial	Cancel CW	*70	1	<input checked="" type="checkbox"/>	<input checked="" type="checkbox"/>	<input checked="" type="checkbox"/>	<input checked="" type="checkbox"/>	<input checked="" type="checkbox"/>
14	Speedial	Unpark	*88	1	<input checked="" type="checkbox"/>	<input checked="" type="checkbox"/>	<input checked="" type="checkbox"/>	<input checked="" type="checkbox"/>	<input checked="" type="checkbox"/>
15	None			1	<input type="checkbox"/>	<input type="checkbox"/>	<input type="checkbox"/>	<input type="checkbox"/>	<input type="checkbox"/>
16	None			1	<input type="checkbox"/>	<input type="checkbox"/>	<input type="checkbox"/>	<input type="checkbox"/>	<input type="checkbox"/>
17	None			1	<input type="checkbox"/>	<input type="checkbox"/>	<input type="checkbox"/>	<input type="checkbox"/>	<input type="checkbox"/>
18	None			1	<input type="checkbox"/>	<input type="checkbox"/>	<input type="checkbox"/>	<input type="checkbox"/>	<input type="checkbox"/>
19	None			1	<input type="checkbox"/>	<input type="checkbox"/>	<input type="checkbox"/>	<input type="checkbox"/>	<input type="checkbox"/>
20	None			1	<input type="checkbox"/>	<input type="checkbox"/>	<input type="checkbox"/>	<input type="checkbox"/>	<input type="checkbox"/>

- Click on the **Bottom Keys** tab or the **Top Keys** tab.
- Select from "Key 1" through "Key 20" on the bottom tab or select from "Key 1" through "Key 10" on the top tab.
- In the **Type** field, select **BLF** to apply to the softkey.
- In the **Label** field, enter a label to apply to this softkey.
- In the **Value** field, enter the phone number or extension you want to monitor.
- In the **Line** field, select a line for which to apply this softkey. Valid values are 1 through 9.
- If configuring a softkey on the Bottom Keys, in the state fields, check (enable) or uncheck (disable) the states you want to apply to this softkey.
- Click to save your changes.

Flash Key

You can set a softkey to generate a flash event when it is pressed on the 6757i CT handset. You do this by setting the softkey to "Flash". The IP phone generates flash events only when a call is connected and there is an active RTP stream (for example, when the call is not on hold).

Setting a Flash Key



Packet8 Web Phone UI

1. Click on Operation->Softkeys and XML.

Key	Type	Label	Value	Line	Idle	Connected	Incoming	Outgoing	Busy
1	Speedial	labtest	1111	2	<input checked="" type="checkbox"/>	<input checked="" type="checkbox"/>	<input checked="" type="checkbox"/>	<input checked="" type="checkbox"/>	<input checked="" type="checkbox"/>
2	Speedial	Panel		1	<input checked="" type="checkbox"/>	<input checked="" type="checkbox"/>	<input checked="" type="checkbox"/>	<input checked="" type="checkbox"/>	<input checked="" type="checkbox"/>
3	Speedial	Speed Dial	1111	1	<input checked="" type="checkbox"/>	<input checked="" type="checkbox"/>	<input checked="" type="checkbox"/>	<input checked="" type="checkbox"/>	<input checked="" type="checkbox"/>
4	Speedial	Call Return	*60	1	<input checked="" type="checkbox"/>	<input checked="" type="checkbox"/>	<input checked="" type="checkbox"/>	<input checked="" type="checkbox"/>	<input checked="" type="checkbox"/>
5	Speedial	Pickup	*68	1	<input checked="" type="checkbox"/>	<input checked="" type="checkbox"/>	<input checked="" type="checkbox"/>	<input checked="" type="checkbox"/>	<input checked="" type="checkbox"/>
6	Speedial	CallFeedOn	*72	1	<input checked="" type="checkbox"/>	<input checked="" type="checkbox"/>	<input checked="" type="checkbox"/>	<input checked="" type="checkbox"/>	<input checked="" type="checkbox"/>
7	Speedial	CallFeedOff	*73	1	<input checked="" type="checkbox"/>	<input checked="" type="checkbox"/>	<input checked="" type="checkbox"/>	<input checked="" type="checkbox"/>	<input checked="" type="checkbox"/>
8	Speedial	DND On	*78	1	<input checked="" type="checkbox"/>	<input checked="" type="checkbox"/>	<input checked="" type="checkbox"/>	<input checked="" type="checkbox"/>	<input checked="" type="checkbox"/>
9	Speedial	DND Off	*79	1	<input checked="" type="checkbox"/>	<input checked="" type="checkbox"/>	<input checked="" type="checkbox"/>	<input checked="" type="checkbox"/>	<input checked="" type="checkbox"/>
10	Speedial	CLIRBlock	*87	1	<input checked="" type="checkbox"/>	<input checked="" type="checkbox"/>	<input checked="" type="checkbox"/>	<input checked="" type="checkbox"/>	<input checked="" type="checkbox"/>
11	Speedial	Trace	*87	1	<input checked="" type="checkbox"/>	<input checked="" type="checkbox"/>	<input checked="" type="checkbox"/>	<input checked="" type="checkbox"/>	<input checked="" type="checkbox"/>
12	Speedial	Clear MMR	*99	1	<input checked="" type="checkbox"/>	<input checked="" type="checkbox"/>	<input checked="" type="checkbox"/>	<input checked="" type="checkbox"/>	<input checked="" type="checkbox"/>
13	Speedial	Cancel CW	*70	1	<input checked="" type="checkbox"/>	<input checked="" type="checkbox"/>	<input checked="" type="checkbox"/>	<input checked="" type="checkbox"/>	<input checked="" type="checkbox"/>
14	Speedial	Unpak	*88	1	<input checked="" type="checkbox"/>	<input checked="" type="checkbox"/>	<input checked="" type="checkbox"/>	<input checked="" type="checkbox"/>	<input checked="" type="checkbox"/>
15	None			1	<input type="checkbox"/>	<input checked="" type="checkbox"/>	<input checked="" type="checkbox"/>	<input checked="" type="checkbox"/>	<input checked="" type="checkbox"/>
16	None			1	<input type="checkbox"/>	<input checked="" type="checkbox"/>	<input checked="" type="checkbox"/>	<input checked="" type="checkbox"/>	<input checked="" type="checkbox"/>
17	None			1	<input type="checkbox"/>	<input checked="" type="checkbox"/>	<input checked="" type="checkbox"/>	<input checked="" type="checkbox"/>	<input checked="" type="checkbox"/>
18	None			1	<input type="checkbox"/>	<input checked="" type="checkbox"/>	<input checked="" type="checkbox"/>	<input checked="" type="checkbox"/>	<input checked="" type="checkbox"/>
19	None			1	<input type="checkbox"/>	<input checked="" type="checkbox"/>	<input checked="" type="checkbox"/>	<input checked="" type="checkbox"/>	<input checked="" type="checkbox"/>
20	None			1	<input type="checkbox"/>	<input checked="" type="checkbox"/>	<input checked="" type="checkbox"/>	<input checked="" type="checkbox"/>	<input checked="" type="checkbox"/>

2. Click on the **Bottom** tab or the **Top** tab.
3. Select from "Key 1" through "Key 20" on the bottom tab or select from "Key 1" through "Key 10" on the top tab.
4. In the **Type** field, select **Flash**.
5. In the **Label** field, enter a label to display on the phone for the softkey.
6. Click to save your changes.

Services Key

By default, the 6757i CT has a Services key configured on key 1 of the top set of keys. However, you can use any softkey to configure a **Services** key.

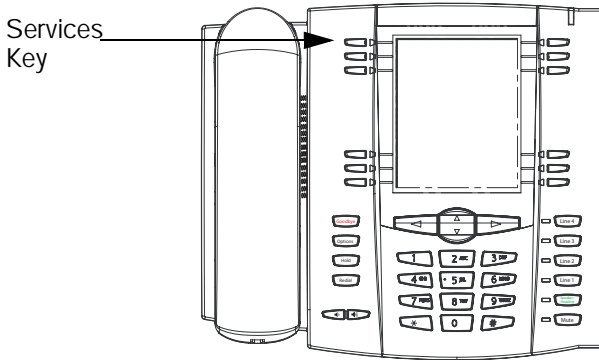

The Services key accesses enhanced features and services. Using the **Services** key, you can:

- Utilize a Caller List
- Utilize a Directory
- Utilize Voicemail



Note: Other than the Services Menu, you can also configure the Caller List and Phonebook on separate keys.

Reference

For more information about Caller List, Directory, and Voicemail, see the following:

- ["Callers List" on page 98](#)
- ["Phonebook" on page 67](#)
- ["Voicemail System" on page 108](#)

Setting Services Key



Packet8 Web Phone UI

Use the following procedure to configure a Services softkey on the 6757i CT phone. The following illustration shows the top softkeys on the 6757i CT.



Note: By default, Key 1 on the top set of softkeys is configured for Services.

1. Click on **Operation->Softkeys and XML**.
or
Click on **Operation->Expansion Module <N>**.

Key	Type	Label	Value	Line
1	Services			global
2	Directory			1
3	Callen List			1
4	Intercom			global
5	None			1
6	None			1
7	None			1
8	None			1
9	None			1
10	None			1

Services

XML Application URI:

XML Application Title:

BLF List URI:

2. Click on the **Bottom** tab or the **Top** tab.
3. Select from "**Key 1**" through "**Key 20**" on the bottom tab or select from "**Key 1**" through "**Key 10**" on the top tab.
4. In the **Type** field, select **Services**.
5. In the **Label** field, enter a label to apply to this softkey.
6. In the **Line** field, select the line you want to apply to this softkey. Valid values are 1 through 9.
7. If configuring a softkey on the Bottom Keys, in the state fields, check (**enable**) or uncheck (**disable**) the states you want to apply to this softkey.
8. Click to save your changes.

Directory Key

By default, the 6757i CT has a Directory key configured on key 2 of the top set of keys. However, using the Packet8 Web Phone UI, you can assign the Directory key to any softkey on the top or bottom keys on the phone.

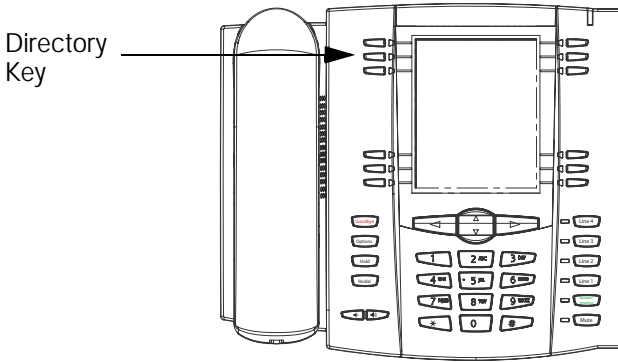

The **Phonebook** feature allows you to store frequently used names and numbers on the phone. You can also dial directly from a directory entry.

You can use the Directory key to access a Phonebook which contains a customized list of names with phone numbers and labels.

In addition to creating a Directory softkey, you can also download a Phonebook to your PC if required using the Packet8 Web Phone UI.

Reference

For more information about the Phonebook, see "[Phonebook](#)" on [page 67](#).

Setting Directory Key



Packet8 Web Phone UI

Use the following procedure to configure a Directory softkey on the 6757i CT phone. The following illustration shows the top softkeys on the 6757i CT.



Note: By default, Key 2 on the top set of softkeys is configured for Directory.

1. Click on **Operation->Softkeys and XML**.
or
Click on **Operation->Expansion Module <N>**.

Key	Type	Label	Value	Line
1	Service			enable
2	Directory			enable
3	Callen List			enable
4	Intercom			enable
5	None			enable
6	None			enable
7	None			enable
8	None			enable
9	None			enable
10	None			enable

Services

XML Application URI:

XML Application Title:

BLF List URI:

2. Click on the **Bottom** tab or the **Top** tab.
3. Select from "Key 1" through "Key 20" on the bottom tab or select from "Key 1" through "Key 10" on the top tab.
4. In the **Type** field, select **Directory**.
5. In the **Label** field, enter a label to apply to this softkey.
6. If configuring a softkey on the Bottom Keys, in the state fields, check (**enable**) or uncheck (**disable**) the states you want to apply to this softkey.
7. Click  to save your changes.

Phonebook

By default, the 6757i CT has a Phonebook key configured on key 3 of the top set of keys. However, using the Packet8 Web Phone UI, you can assign the Phonebook key to any softkey on the top or bottom keys on the phone.

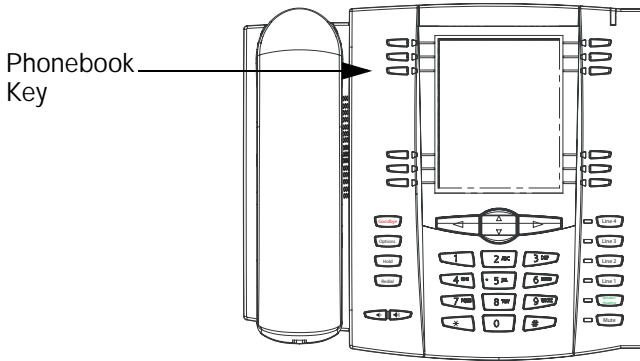

The Phonebook is a stored log of your incoming calls. You can use the Phonebook key to access a list of callers that called your phone.

Reference

For more information about the Phonebook, see ["Phonebook"](#) on [page 67](#).

Corporate Directory Key

By Default, the 6757i CT has a Corporate Directory key configured on key 1 of the bottom set of keys. However using the Packet8 Web Phone UI, you can assign the Corporate Directory key to any softkey on the top or bottom keys on the phone. Show diagram. The Corporate Directory feature allows you to quickly access the list of names with extension number of everyone in the company.

Corporate Directory Search

By default, the 6757i CT has a Corporate Directory Search key on 16 of the bottom set of keys. However, using the Packet8 Web Phone UI, you can assign the Corporate Directory Search key to any softkey on the top or bottom keys on the phone.

The Corporate Directory Search feature allow you to search for an extension number in your company using first, or last name.

Reference

For more information about the Corporate Direcotry, see ["Corporate Directory Key"](#) on [page 67](#).

Setting Callers List Key



Packet8 Web Phone UI

Use the following procedure to configure a Callers List softkey on the 6757i CT phone. The following illustration shows the top softkeys on the 6757i CT.



Note: By default, Key 3 on the top set of softkeys is configured for Callers List.

1. Click on **Operation->Softkeys and XML**.
or
Click on **Operation->Expansion Module <N>**.

Key	Type	Label	Value	Line
1	Services			global
2	Directory			1-20
3	Callers List			1-20
4	Intercom			global
5	None			1-20
6	None			1-20
7	None			1-20
8	None			1-20
9	None			1-20
10	None			1-20

Services

>XML Application URI:

>XML Application Title:

BLF List URI:

2. Click on the **Bottom** tab or the **Top** tab.
3. Select from "**Key 1**" through "**Key 20**" on the bottom tab or select from "**Key 1**" through "**Key 10**" on the top tab.
4. In the **Type** field, select **Callers List**.
5. In the **Label** field, enter a label to apply to this softkey.
6. If configuring a softkey on the Bottom Keys, in the state fields, check (**enable**) or uncheck (**disable**) the states you want to apply to this softkey.
7. Click  to save your changes.

Intercom Key

By default, the 6757i CT has an Intercom key configured on key 4 of the top set of keys. However, using the Packet8 Web Phone UI, you can assign the Intercom key to any softkey on the top or bottom keys on the phone.

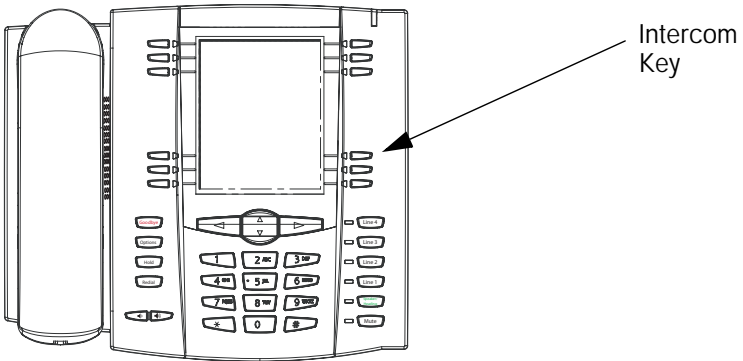

You can use the Intercom key to automatically connect with a remote extension for outgoing calls, and to answer an incoming Intercom call.

Reference

For more information about the Intercom key, see ["Intercom Key"](#) on [page 69](#).

Setting an Intercom Key



Packet8 Web Phone UI

Use the following procedure to configure an Intercom softkey on the 6757i CT phone. The following illustration shows the top softkeys on the 6757i CT.



Note: By default, Key 14 on the top set of softkeys is configured for Intercom.

1. Click on **Operation->Softkeys and XML**.
or
Click on **Operation->Expansion Module <N>**.

Key	Type	Label	Value	Line
1	Service			global
2	Directory			1-20
3	Call Log			1-20
4	Intercom			global
5	None			1-20
6	None			1-20
7	None			1-20
8	None			1-20
9	None			1-20
10	None			1-20

Services

XML Application URI:

XML Application Title:

BLF List URI:

2. Click on the **Bottom** tab or the **Top** tab.
3. Select from "**Key 1**" through "**Key 20**" on the bottom tab or select from "**Key 1**" through "**Key 10**" on the top tab.
4. In the "**Type**" field, select **Intercom**.
5. In the "**Label**" field, enter a label to apply to this softkey.
6. If configuring a softkey on the Bottom Keys, in the state fields, check (enable) or uncheck (disable) the states you want to apply to this softkey.
7. Click to save your changes.

None Key

You can set a key to force a blank entry on the IP phone display for a specific key. You do this by setting the key to **none**. The keys are added in order (from key 1 to key 20) after any hard-coded keys have been added. If a particular key is not defined, it is ignored. For more information about key behavior, see "Key Display Behavior" on page 52.

Setting a None Key



Packet8 Web Phone UI

Use the following procedure to configure a None key on the 6757i CT IP Phone.

1. Click on **Operation->Softkeys and XML**.
OR
Click on **Operation->Expansion Module <N>**.

Key	Type	Label	Value	Line	Ink	Connected	Incoming	Outgoing	Busy
1	BLFList	Lastest	1111	2	<input checked="" type="checkbox"/>	<input checked="" type="checkbox"/>	<input checked="" type="checkbox"/>	<input checked="" type="checkbox"/>	<input checked="" type="checkbox"/>
2	Speeddial	Portal		1	<input checked="" type="checkbox"/>	<input checked="" type="checkbox"/>	<input checked="" type="checkbox"/>	<input checked="" type="checkbox"/>	<input checked="" type="checkbox"/>
3	Speeddial	Speed Dial	1111	1	<input checked="" type="checkbox"/>	<input checked="" type="checkbox"/>	<input checked="" type="checkbox"/>	<input checked="" type="checkbox"/>	<input checked="" type="checkbox"/>
4	Speeddial	Call Return	*90	1	<input checked="" type="checkbox"/>	<input checked="" type="checkbox"/>	<input checked="" type="checkbox"/>	<input checked="" type="checkbox"/>	<input checked="" type="checkbox"/>
5	Speeddial	Pickup	*98	1	<input checked="" type="checkbox"/>	<input checked="" type="checkbox"/>	<input checked="" type="checkbox"/>	<input checked="" type="checkbox"/>	<input checked="" type="checkbox"/>
6	Speeddial	CallFwdOn	*72	1	<input checked="" type="checkbox"/>	<input checked="" type="checkbox"/>	<input checked="" type="checkbox"/>	<input checked="" type="checkbox"/>	<input checked="" type="checkbox"/>
7	Speeddial	CallFwdOff	*73	1	<input checked="" type="checkbox"/>	<input checked="" type="checkbox"/>	<input checked="" type="checkbox"/>	<input checked="" type="checkbox"/>	<input checked="" type="checkbox"/>
8	Speeddial	DND On	*79	1	<input checked="" type="checkbox"/>	<input checked="" type="checkbox"/>	<input checked="" type="checkbox"/>	<input checked="" type="checkbox"/>	<input checked="" type="checkbox"/>
9	Speeddial	DND Off	*79	1	<input checked="" type="checkbox"/>	<input checked="" type="checkbox"/>	<input checked="" type="checkbox"/>	<input checked="" type="checkbox"/>	<input checked="" type="checkbox"/>
10	Speeddial	CLIDBlock	*07	1	<input checked="" type="checkbox"/>	<input checked="" type="checkbox"/>	<input checked="" type="checkbox"/>	<input checked="" type="checkbox"/>	<input checked="" type="checkbox"/>
11	Speeddial	Trace	*97	1	<input checked="" type="checkbox"/>	<input checked="" type="checkbox"/>	<input checked="" type="checkbox"/>	<input checked="" type="checkbox"/>	<input checked="" type="checkbox"/>
12	Speeddial	Clear MM	*99	1	<input checked="" type="checkbox"/>	<input checked="" type="checkbox"/>	<input checked="" type="checkbox"/>	<input checked="" type="checkbox"/>	<input checked="" type="checkbox"/>
13	Speeddial	Cancel CW	*70	1	<input checked="" type="checkbox"/>	<input checked="" type="checkbox"/>	<input checked="" type="checkbox"/>	<input checked="" type="checkbox"/>	<input checked="" type="checkbox"/>
14	Speeddial	Unpak	*99	1	<input checked="" type="checkbox"/>	<input checked="" type="checkbox"/>	<input checked="" type="checkbox"/>	<input checked="" type="checkbox"/>	<input checked="" type="checkbox"/>
15	None			1	<input checked="" type="checkbox"/>	<input checked="" type="checkbox"/>	<input checked="" type="checkbox"/>	<input checked="" type="checkbox"/>	<input checked="" type="checkbox"/>
16	None			1	<input checked="" type="checkbox"/>	<input checked="" type="checkbox"/>	<input checked="" type="checkbox"/>	<input checked="" type="checkbox"/>	<input checked="" type="checkbox"/>
17	None			1	<input checked="" type="checkbox"/>	<input checked="" type="checkbox"/>	<input checked="" type="checkbox"/>	<input checked="" type="checkbox"/>	<input checked="" type="checkbox"/>
18	None			1	<input checked="" type="checkbox"/>	<input checked="" type="checkbox"/>	<input checked="" type="checkbox"/>	<input checked="" type="checkbox"/>	<input checked="" type="checkbox"/>
19	None			1	<input checked="" type="checkbox"/>	<input checked="" type="checkbox"/>	<input checked="" type="checkbox"/>	<input checked="" type="checkbox"/>	<input checked="" type="checkbox"/>
20	None			1	<input checked="" type="checkbox"/>	<input checked="" type="checkbox"/>	<input checked="" type="checkbox"/>	<input checked="" type="checkbox"/>	<input checked="" type="checkbox"/>

Services

XML Application URI:

XML Application Title:

BLF List URI:

2. Click on the **Bottom** tab or the **Top** tab.
3. Select from "Key 1" through "Key 20" on the bottom tab or select from "Key 1" through "Key 10" on the top tab.
4. In the **Type** field, select **None**.
5. If configuring a softkey on the Bottom Keys, in the state fields, check (**enable**) or uncheck (**disable**) the states you want to apply to this softkey.
6. Click to save your changes.

Empty Key

You can set a softkey to force a blank entry on the IP phone display for a specific softkey. You do this by setting the softkey to **empty**. The softkeys are added in order (from softkey1 to softkey 20) after any hard-coded keys have been added. If a particular softkey is not defined, it is ignored.

Setting an Empty Key



Packet8 Web Phone UI

Use the following procedure to configure an Empty softkey on the 6757i CT phone.

1. Click on **Operation->Softkeys and XML**.
or
Click on **Operation->Expansion Module <N>**.

Key	Type	Label	Value	Line	State	Connected	Incoming	Outgoing	Busy
1	BLFList	John	1111	2	<input checked="" type="checkbox"/>	<input checked="" type="checkbox"/>	<input checked="" type="checkbox"/>	<input checked="" type="checkbox"/>	<input checked="" type="checkbox"/>
2	Speedial	Portal		1	<input checked="" type="checkbox"/>	<input checked="" type="checkbox"/>	<input checked="" type="checkbox"/>	<input checked="" type="checkbox"/>	<input checked="" type="checkbox"/>
3	Speedial	Speed Dial	1111	1	<input checked="" type="checkbox"/>	<input checked="" type="checkbox"/>	<input checked="" type="checkbox"/>	<input checked="" type="checkbox"/>	<input checked="" type="checkbox"/>
4	Speedial	Call Return	*69	1	<input checked="" type="checkbox"/>	<input checked="" type="checkbox"/>	<input checked="" type="checkbox"/>	<input checked="" type="checkbox"/>	<input checked="" type="checkbox"/>
5	Speedial	Pickup	*90	1	<input checked="" type="checkbox"/>	<input checked="" type="checkbox"/>	<input checked="" type="checkbox"/>	<input checked="" type="checkbox"/>	<input checked="" type="checkbox"/>
6	Speedial	CallForward	*72	1	<input checked="" type="checkbox"/>	<input checked="" type="checkbox"/>	<input checked="" type="checkbox"/>	<input checked="" type="checkbox"/>	<input checked="" type="checkbox"/>
7	Speedial	CallForward	*73	1	<input checked="" type="checkbox"/>	<input checked="" type="checkbox"/>	<input checked="" type="checkbox"/>	<input checked="" type="checkbox"/>	<input checked="" type="checkbox"/>
8	Speedial	DND On	*78	1	<input checked="" type="checkbox"/>	<input checked="" type="checkbox"/>	<input checked="" type="checkbox"/>	<input checked="" type="checkbox"/>	<input checked="" type="checkbox"/>
9	Speedial	DND Off	*79	1	<input checked="" type="checkbox"/>	<input checked="" type="checkbox"/>	<input checked="" type="checkbox"/>	<input checked="" type="checkbox"/>	<input checked="" type="checkbox"/>
10	Speedial	CLIDBlock	*67	1	<input checked="" type="checkbox"/>	<input checked="" type="checkbox"/>	<input checked="" type="checkbox"/>	<input checked="" type="checkbox"/>	<input checked="" type="checkbox"/>
11	Speedial	Trace	*67	1	<input checked="" type="checkbox"/>	<input checked="" type="checkbox"/>	<input checked="" type="checkbox"/>	<input checked="" type="checkbox"/>	<input checked="" type="checkbox"/>
12	Speedial	Clear MW	*99	1	<input checked="" type="checkbox"/>	<input checked="" type="checkbox"/>	<input checked="" type="checkbox"/>	<input checked="" type="checkbox"/>	<input checked="" type="checkbox"/>
13	Speedial	Cancel CW	*70	1	<input checked="" type="checkbox"/>	<input checked="" type="checkbox"/>	<input checked="" type="checkbox"/>	<input checked="" type="checkbox"/>	<input checked="" type="checkbox"/>
14	Speedial	Unpark	*88	1	<input checked="" type="checkbox"/>	<input checked="" type="checkbox"/>	<input checked="" type="checkbox"/>	<input checked="" type="checkbox"/>	<input checked="" type="checkbox"/>
15	None			1	<input type="checkbox"/>	<input type="checkbox"/>	<input type="checkbox"/>	<input type="checkbox"/>	<input type="checkbox"/>
16	None			1	<input type="checkbox"/>	<input type="checkbox"/>	<input type="checkbox"/>	<input type="checkbox"/>	<input type="checkbox"/>
17	None			1	<input type="checkbox"/>	<input type="checkbox"/>	<input type="checkbox"/>	<input type="checkbox"/>	<input type="checkbox"/>
18	None			1	<input type="checkbox"/>	<input type="checkbox"/>	<input type="checkbox"/>	<input type="checkbox"/>	<input type="checkbox"/>
19	None			1	<input type="checkbox"/>	<input type="checkbox"/>	<input type="checkbox"/>	<input type="checkbox"/>	<input type="checkbox"/>
20	None			1	<input type="checkbox"/>	<input type="checkbox"/>	<input type="checkbox"/>	<input type="checkbox"/>	<input type="checkbox"/>

Services

XML Application URI:

XML Application Title:

BLF List URI:

2. Click on the **Bottom** tab or the **Top** tab.
3. Select from "Key 1" through "Key 20" on the bottom tab or select from "Key 1" through "Key 10" on the top tab.
4. In the **Type** field, select **Empty**.
5. If configuring a softkey on the Bottom Keys, in the state fields, check (**enable**) or uncheck (**disable**) the states you want to apply to this softkey.
6. Click to save your changes.

Phone Lock Key

You can configure a key on the IP Phone to use as a lock/unlock key. You assign the function of the key as **Phone Lock**.

Setting a Phone Lock Key



Packet8 Web Phone UI

Use the following procedure to configure a Phone Lock key on the 6757i CT IP Phone.

1. Click on **Operation->Softkeys and XML**.
or
Click on **Operation->Expansion Module <N>**.

Key	Type	Label	Value	Line	Idle	Connected	Incoming	Outgoing	Busy
1	Phone Lock			1	<input checked="" type="checkbox"/>	<input checked="" type="checkbox"/>	<input checked="" type="checkbox"/>	<input checked="" type="checkbox"/>	<input checked="" type="checkbox"/>
2	None			1	<input checked="" type="checkbox"/>	<input checked="" type="checkbox"/>	<input checked="" type="checkbox"/>	<input checked="" type="checkbox"/>	<input checked="" type="checkbox"/>
3	None			1	<input checked="" type="checkbox"/>	<input checked="" type="checkbox"/>	<input checked="" type="checkbox"/>	<input checked="" type="checkbox"/>	<input checked="" type="checkbox"/>
4	None			1	<input checked="" type="checkbox"/>	<input checked="" type="checkbox"/>	<input checked="" type="checkbox"/>	<input checked="" type="checkbox"/>	<input checked="" type="checkbox"/>
5	None			1	<input checked="" type="checkbox"/>	<input checked="" type="checkbox"/>	<input checked="" type="checkbox"/>	<input checked="" type="checkbox"/>	<input checked="" type="checkbox"/>
6	None			1	<input checked="" type="checkbox"/>	<input checked="" type="checkbox"/>	<input checked="" type="checkbox"/>	<input checked="" type="checkbox"/>	<input checked="" type="checkbox"/>
7	None			1	<input checked="" type="checkbox"/>	<input checked="" type="checkbox"/>	<input checked="" type="checkbox"/>	<input checked="" type="checkbox"/>	<input checked="" type="checkbox"/>
8	None			1	<input checked="" type="checkbox"/>	<input checked="" type="checkbox"/>	<input checked="" type="checkbox"/>	<input checked="" type="checkbox"/>	<input checked="" type="checkbox"/>
9	None			1	<input checked="" type="checkbox"/>	<input checked="" type="checkbox"/>	<input checked="" type="checkbox"/>	<input checked="" type="checkbox"/>	<input checked="" type="checkbox"/>
10	None			1	<input checked="" type="checkbox"/>	<input checked="" type="checkbox"/>	<input checked="" type="checkbox"/>	<input checked="" type="checkbox"/>	<input checked="" type="checkbox"/>
11	None			1	<input checked="" type="checkbox"/>	<input checked="" type="checkbox"/>	<input checked="" type="checkbox"/>	<input checked="" type="checkbox"/>	<input checked="" type="checkbox"/>
12	None			1	<input checked="" type="checkbox"/>	<input checked="" type="checkbox"/>	<input checked="" type="checkbox"/>	<input checked="" type="checkbox"/>	<input checked="" type="checkbox"/>
13	None			1	<input checked="" type="checkbox"/>	<input checked="" type="checkbox"/>	<input checked="" type="checkbox"/>	<input checked="" type="checkbox"/>	<input checked="" type="checkbox"/>
14	None			1	<input checked="" type="checkbox"/>	<input checked="" type="checkbox"/>	<input checked="" type="checkbox"/>	<input checked="" type="checkbox"/>	<input checked="" type="checkbox"/>
15	None			1	<input checked="" type="checkbox"/>	<input checked="" type="checkbox"/>	<input checked="" type="checkbox"/>	<input checked="" type="checkbox"/>	<input checked="" type="checkbox"/>
16	None			1	<input checked="" type="checkbox"/>	<input checked="" type="checkbox"/>	<input checked="" type="checkbox"/>	<input checked="" type="checkbox"/>	<input checked="" type="checkbox"/>
17	None			1	<input checked="" type="checkbox"/>	<input checked="" type="checkbox"/>	<input checked="" type="checkbox"/>	<input checked="" type="checkbox"/>	<input checked="" type="checkbox"/>
18	None			1	<input checked="" type="checkbox"/>	<input checked="" type="checkbox"/>	<input checked="" type="checkbox"/>	<input checked="" type="checkbox"/>	<input checked="" type="checkbox"/>
19	None			1	<input checked="" type="checkbox"/>	<input checked="" type="checkbox"/>	<input checked="" type="checkbox"/>	<input checked="" type="checkbox"/>	<input checked="" type="checkbox"/>
20	None			1	<input checked="" type="checkbox"/>	<input checked="" type="checkbox"/>	<input checked="" type="checkbox"/>	<input checked="" type="checkbox"/>	<input checked="" type="checkbox"/>

2. Click on the **Bottom** tab or the **Top** tab.
3. Select from "Key 1" through "Key 20" on the bottom tab or select from "Key 1" through "Key 10" on the top tab.
4. In the **Type** field, select **Phone Lock** from the list of options.
5. Click to save your changes.



Note: You can lock/unlock the phone using the new key you just configured, using the Packet8 Web Phone UI at the path **Operation->PhoneLock**, or using the **Phone Lock** option on the IP Phone UI at the path **Options->Phone Lock**. For more information about using the lock/unlock feature, see "[Locking/Unlocking a Phone](#)" on [page 44](#).

Using the Lock/Unlock Key on the IP Phone

After configuring a key as a lock/unlock key, refer to the following procedure to use the key on the IP phone.

Lock the Phone

1. Press the **LOCK** key. The phone locks. The LED for the key AND the Message Waiting Lamp illuminate steady ON. An **Unlock** label appears next to the key you just pressed.

Unlock the Phone

1. Press the **UNLOCK** key. A password prompt displays.
2. Enter your user password and press **ENTER**. The phone unlocks. The LED for the key AND the Message Waiting Lamp go OFF. The **Lock** label appears next to the key you just pressed.

Deleting a Key



Packet8 Web Phone UI

Use the following procedure to delete a key function on the 6757i CT IP Phone.

1. Click on **Operation->Softkeys and XML** or **Operation->Expansion Module <N>**.

Key	Type	Label	Value	Line	Idle	Connected	Incoming	Outgoing	Busy
1	Phone Lock			1	<input checked="" type="checkbox"/>	<input checked="" type="checkbox"/>	<input checked="" type="checkbox"/>	<input checked="" type="checkbox"/>	<input checked="" type="checkbox"/>
2	None			1	<input checked="" type="checkbox"/>	<input checked="" type="checkbox"/>	<input checked="" type="checkbox"/>	<input checked="" type="checkbox"/>	<input checked="" type="checkbox"/>
3	None			1	<input checked="" type="checkbox"/>	<input checked="" type="checkbox"/>	<input checked="" type="checkbox"/>	<input checked="" type="checkbox"/>	<input checked="" type="checkbox"/>
4	None			1	<input checked="" type="checkbox"/>	<input checked="" type="checkbox"/>	<input checked="" type="checkbox"/>	<input checked="" type="checkbox"/>	<input checked="" type="checkbox"/>
5	None			1	<input checked="" type="checkbox"/>	<input checked="" type="checkbox"/>	<input checked="" type="checkbox"/>	<input checked="" type="checkbox"/>	<input checked="" type="checkbox"/>
6	None			1	<input checked="" type="checkbox"/>	<input checked="" type="checkbox"/>	<input checked="" type="checkbox"/>	<input checked="" type="checkbox"/>	<input checked="" type="checkbox"/>
7	None			1	<input checked="" type="checkbox"/>	<input checked="" type="checkbox"/>	<input checked="" type="checkbox"/>	<input checked="" type="checkbox"/>	<input checked="" type="checkbox"/>
8	None			1	<input checked="" type="checkbox"/>	<input checked="" type="checkbox"/>	<input checked="" type="checkbox"/>	<input checked="" type="checkbox"/>	<input checked="" type="checkbox"/>
9	None			1	<input checked="" type="checkbox"/>	<input checked="" type="checkbox"/>	<input checked="" type="checkbox"/>	<input checked="" type="checkbox"/>	<input checked="" type="checkbox"/>
10	None			1	<input checked="" type="checkbox"/>	<input checked="" type="checkbox"/>	<input checked="" type="checkbox"/>	<input checked="" type="checkbox"/>	<input checked="" type="checkbox"/>
11	None			1	<input checked="" type="checkbox"/>	<input checked="" type="checkbox"/>	<input checked="" type="checkbox"/>	<input checked="" type="checkbox"/>	<input checked="" type="checkbox"/>
12	None			1	<input checked="" type="checkbox"/>	<input checked="" type="checkbox"/>	<input checked="" type="checkbox"/>	<input checked="" type="checkbox"/>	<input checked="" type="checkbox"/>
13	None			1	<input checked="" type="checkbox"/>	<input checked="" type="checkbox"/>	<input checked="" type="checkbox"/>	<input checked="" type="checkbox"/>	<input checked="" type="checkbox"/>
14	None			1	<input checked="" type="checkbox"/>	<input checked="" type="checkbox"/>	<input checked="" type="checkbox"/>	<input checked="" type="checkbox"/>	<input checked="" type="checkbox"/>
15	None			1	<input checked="" type="checkbox"/>	<input checked="" type="checkbox"/>	<input checked="" type="checkbox"/>	<input checked="" type="checkbox"/>	<input checked="" type="checkbox"/>
16	None			1	<input checked="" type="checkbox"/>	<input checked="" type="checkbox"/>	<input checked="" type="checkbox"/>	<input checked="" type="checkbox"/>	<input checked="" type="checkbox"/>
17	None			1	<input checked="" type="checkbox"/>	<input checked="" type="checkbox"/>	<input checked="" type="checkbox"/>	<input checked="" type="checkbox"/>	<input checked="" type="checkbox"/>
18	None			1	<input checked="" type="checkbox"/>	<input checked="" type="checkbox"/>	<input checked="" type="checkbox"/>	<input checked="" type="checkbox"/>	<input checked="" type="checkbox"/>
19	None			1	<input checked="" type="checkbox"/>	<input checked="" type="checkbox"/>	<input checked="" type="checkbox"/>	<input checked="" type="checkbox"/>	<input checked="" type="checkbox"/>
20	None			1	<input checked="" type="checkbox"/>	<input checked="" type="checkbox"/>	<input checked="" type="checkbox"/>	<input checked="" type="checkbox"/>	<input checked="" type="checkbox"/>

2. Click on the **Bottom** tab or the **Top** tab.
3. Select from "Key 1" through "Key 20" on the bottom tab or select from "Key 1" through "Key 10" on the top tab.
4. In the **Type** field, select **None**.
5. Click to save your changes. The softkey function is deleted from the IP phone memory.

Making Calls

This section describes ways to make calls on your 6757i CT phone, using your handset, speakerphone or headset.

Dialing a Number

First, take the phone off-hook by:

- lifting the handset
- pressing  or
- pressing a line/call appearance button

At the dial tone, enter the number you wish to call



Note: After dialing the number, the phone has a short delay before sending the call. To send the call immediately, you can press the "Dial" soft-key (if the handset is offhook) or the "#" key immediately after dialing the number. The phone sends the call without delay.

If you are unable to make calls within certain area codes, check with your System Administrator for any toll restrictions placed on your extension that may restrict your access to long distance area codes or dialling prefixes.

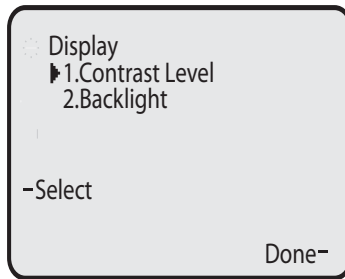

When your party picks up, a timer appears on your display that records the length of your call.

If the Live DialPad option is on, as soon as you press the first digit on the dial pad the phone automatically selects the next available line, go off-hook and dial as digits are pressed.

Pre-dialing a Number

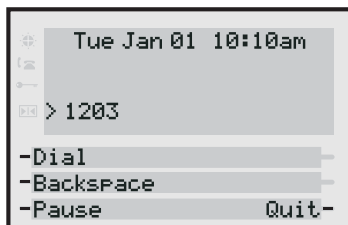

You can also make a call by pre-dialling a number. Pre-dialling lets you view a number before you dial. Use the **Backspace** softkey to correct any errors.

To Call an Outside Number

Pick up the phone or press . Dial 9 and then the number (7-digit if in same area code, or 9+1+area code+number).





Note: You will not hear a dial tone after pressing "9" when making an outside call.

To Call Another Extension



Pick up the phone or press . Dial the extension number.

Making a Call

1. Pick up the Handset, press the  button, or press the  button (when a headset is used), and listen for a dial tone.
2. Using the keypad, dial the desired telephone number. The number you are dialing will appear on the display as you dial. When making a call or talking on the phone, the "In Use" light will light up indicating the phone is in use. This light will also be lit whenever another phone on the same phone line is in use.

Receiving a Call

1. When you hear the phone ring, simply pick up the handset from the handset cradle. You may also press the [Speaker] button to answer the call to enable the speakerphone. Press the  button to answer using headset, or [Answer] softkey.



When you are finished talking, replace the handset in the handset cradle to end the call. If you have been talking using the speakerphone, press the  button to hang up. You may press the  button to hang up at any time.



Using Handsfree Speakerphone

The handsfree feature allows you to speak to someone without using the handset or headset. Your phone must be in either the Speaker or Speaker/Headset audio mode. For more information about setting the audio mode on your phone, see "Audio Mode" on [page 32](#).



IP Phone UI

- To dial using handsfree, first press  and enter a number at the dial tone.
- To answer a call on your phone using handsfree, press  or the line/call appearance button.

- If you are in Speaker audio mode, lift the handset and press  to switch between handsfree and handset.
- If you are in Speaker/Headset audio mode, press  to switch between handsfree and headset.
- When the handset is on hook, press  to disconnect the call.

When handsfree is on, the speaker light turns on.

Using a Headset

The 6757i CT accepts headsets through the modular RJ22 jack on the back of the phone. Contact your telephone equipment retailer or distributor to purchase a compatible headset, or go to www.Packet8.net.



Note: Customers should read and observe all safety recommendations contained in headset operating guides when using any headset.

Advanced Volume Controls for the Headset Mic

On the 6757i CT, there are 3 options for the headset microphone volume. For more information about the headset microphone, see "[Headset Mic Volume](#)" on [page 33](#).



IP Phone UI

To change this volume:

1. Press  to enter the Options list.
2. Select Preferences and press **Select**.
3. Use ▼ to scroll down to **Set Audio** and press **Select**.
4. Press ▼ to scroll down to **Headset/Mic Volume** and press **Select**.
5. Press ▼ to scroll down to **Headset/Mic Volume** and press **Select**.
6. Use ▼ to scroll down the list to select your desired volume.
7. Press **Enter** to save the setting.
8. Press **Done** to save changes and exit.
9. If you do not wish to save changes, press **Cancel** to return to the previous screen.





Note: By default, the volume for the headset microphone is set to medium.

To Make and Receive Calls Using a Headset



IP Phone UI

1. Ensure that you have selected a headset audio mode by accessing the Options list (under option **Preferences->Set Audio->Audio Mode on the IP Phone**).
2. Plug the headset into the jack.
3. Press the  key to obtain a dial tone or to answer an incoming call.
Depending on the audio mode selected from the options menu, a dial tone or an incoming call is received on either the headset or the handsfree speaker-
phone.
4. Press the  key to end the call.

Using Intercom

On the 6757i CT, you can use the **Intercom** key to automatically connect with a remote extension. By default, the Intercom key is configured as Key 4 on the bottom set of softkeys.

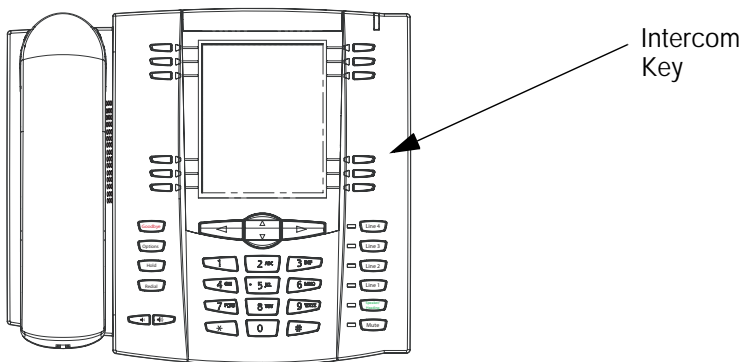

Using the Icom Key



IP Phone UI

1. Press the **Icom** key.
2. Enter the intercom number of the person you wish to Intercom for that extension.
3. After a beep tone, your phone automatically connects with the remote extension and you can speak through its speaker.
4. To cancel Intercom, press  or the **Cancel** key.

- When you are finished speaking, hang up the phone by placing the handset back on-hook or by pressing  or the line/call appearance button for the active call. When you hang up, the remote phone also hangs up.

You can set specific incoming Intercom call features on the 6757i CT IP phone using the Packet8 Web Phone UI. The following table describes these features.



Incoming Intercom Features in Packet8 Web Phone UI	Description
Microphone Mute	Allows you to enable or disable the microphone on the IP phone for Intercom calls made by the originating caller.
Auto Answer	Allows you to enable or disable the IP phone to automatically answer an Intercom call. If auto-answer is enabled on the IP phone, the phone plays a tone (if Play Warning Tone is enabled) to alert the user before answering the Intercom call. If auto-answer is disabled, the phone rejects the incoming Intercom call and sends a busy signal to the caller.
Play Warning Tone	Allows you to enable or disable a warning tone to play when the phone receives an incoming Intercom call on an active line.
Allow Barge In	Allows you to enable or disable how the phone handles incoming Intercom calls while the phone is on an active call.

For more information about the incoming Intercom features and for procedures on setting these features, see "[Incoming Intercom Call Features](#)" on [page 151](#).

Redial



IP Phone UI

- Press  to dial the most recent number you dialed from the phone.
- If you are off-hook and press , the last number you called is called back.
- If you are on-hook and press , a **Redial Phonebook** appears on-screen.

The redial list is available during active calls. It stores up to the last 100 numbers you called, allowing you to scroll through and select the number you wish to redial.







Note: Your System Administrator can set your Redial key to speedial a specific number. Contact your System Administrator for more information.

Accessing the Redial List



IP Phone UI

1. If you are off-hook and press  , the telephone automatically dials the last number you called.
2. If you are not on the phone, press  to display the most recently dialed number and use ▲ ▼ to scroll through the list to view the other numbers.
3. Press ▼ to see the second most recently dialed number, or ▲ to see the oldest call on your list.
4. To dial the displayed number press  , or lift the handset or press any line keys
5. Press  or the  key to cancel.



Note: The redial list is available during active calls. It also stores up to the last 100 numbers you called, allowing you to scroll through and select the number you wish to redial.

Deleting from the Redial List.



Note: You cannot delete individual entries in the Redial List.



IP Phone UI

Delete All Items



1. Press .
2. Press the **Delete** Key, then press the **Delete** Key again at the prompt to erase all items.

Mute

You can use the Mute  key to mute the handset, headset, or speakerphone. When you use the mute key on your phone, you cannot be heard on an active call or on a conference. For muted calls, the handsfree LED flashes and the Mute key LED is ON.



IP Phone UI

You can use the Mute  key to mute the handset, headset, or speakerphone. The speaker light flashes slowly and you can hear the caller, but they cannot hear you. To switch mute on or off, press .



Note: If you place a muted call on hold, the phone automatically takes the call off mute when you reconnect to the call.

Receiving Calls

When a call is ringing at your extension, the inbound caller's extension and name display to the screen. The line/call appearance light flashes quickly for the incoming call.

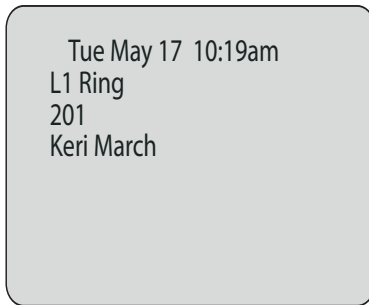



Answering an Incoming Call



IP Phone UI

To answer the call

- For handsfree operation, press  or the line/call appearance button for the incoming call.
- Press  for handsfree or headset operation.



Note: The audio mode setting you have selected in the options list under **Headset Settings** determines if the call goes to handsfree or headset operation. For more information, see the section "[Customizing Your Phone](#)" on [page 25](#).

- Lift the handset for handset operation.

If the phone is already connected to a call, pressing the line/call appearance button for the new incoming call automatically places the connected call on hold and answers the new call. To reconnect to a party, press the line/call appearance button for that call.

If you cannot answer the call, the caller goes to voicemail if voicemail has been configured for your extension.



Note: The  button can be used to cancel the call pickup procedure.

Handling Calls

When you are connected to a call, you can use the softkeys or hard keys on the phone to place a call on hold, transfer a call, or conference.

Placing a Call on Hold

You can place an active call on hold by pressing the Hold  key. When you place a call on hold, only your phone can retrieve the call.



IP Phone UI

To place a call on hold

1. Connect to the call (if not already connected).
2. Press the Hold  key.

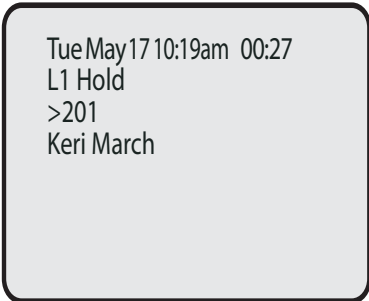

Tue May 17 10:19am 00:27
L1 Hold
>201
Keri March

The line/call appearance light begins to flash slowly and after a short time the phone beeps softly to remind you that you still have a call on hold. The screen displays **Call Held** with the line number the call is held at the phone.



Note: If you are connected to another call, the phone does not beep to remind you that you still have a call on hold.

When on Hold

To let your caller know that they are still on hold, music plays softly (if this has been set up for your system). The call/line appearance light for the line you are on remains solid to indicate that you are still connected.

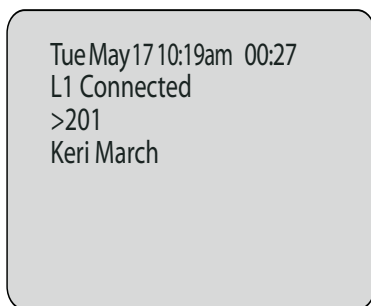

Automatic Hold

When juggling between calls, you do not have to press the hold button to go from one call to the next. The phone automatically puts your current call on hold as soon as you press a new line/call appearance button. If you have more than one call on hold, you can reconnect to a held call by pressing the line/call appearance button where that call is being held. Press  to disconnect the call.

Retrieving a Held Call

If you have more than 1 call on hold, you can scroll through the held call information by pressing 3 and 4 navigation keys. To reconnect to a call press the line/call appearance button where that call is being held. If you press the call/line appearance button again, you disconnect from the call.

Transferring Calls

Blind Transfer

A blind transfer is when you transfer a call directly to another extension without consulting with the person receiving the call. To do this, simply complete the transfer immediately after you have entered the number. The call goes directly to the extension or outside line you transferred to. If the party you are transferring the call to does not answer, the transferred call rings back to your extension.

Consultative Transfer

You also have the option to consult with the person you are transferring the call to, before you complete the transfer. To do this, simply remain on the line until the receiving party answers the call. After consulting with the receiving party, you can either complete the transfer or cancel the transfer to go back to the original call.



IP Phone UI

When you lift the handset on the phone, the **Transfer** key displays on the bottom set of softkeys by default. Use this key to transfer calls.



Screen that displays when handset is lifted

Use the following procedure to transfer a call to another extension. Use the following illustration as a reference.

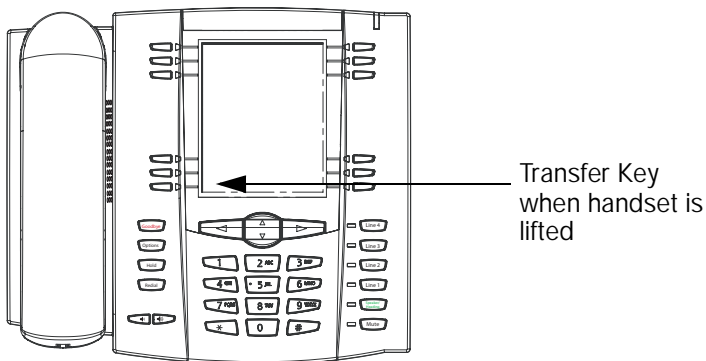

To transfer a call to another extension

1. Connect to Party 1 (if not already connected). Party 1 is the party you want to transfer.
2. Press the **Transfer** key. You should hear a dial tone as a second line opens up.
3. Press a line/call appearance button followed by the extension number (or the outside number) to Party 2. This is the Party for which you want to transfer Party 1
4. To complete a **blind** transfer, press the **Transfer** Key again before the receiving end answers. To complete a consultative transfer, remain on the line to speak with Party 2, before pressing the **Transfer** Key again to transfer Party 1 to Party 2. To cancel the transfer, select **Cancel** on the display screen or press .

Conferencing Calls

The 6757i CT IP phone offers two methods of conferencing:

- Local conferencing (default method).

When you lift the handset on the phone, the **Conference** key displays on the bottom set of softkeys by default. Use this key to create conference calls.



Screen that displays when handset is lifted

Local Conferencing

The 6757i CT phone supports up to 3 parties (including yourself) in a conference call. This is called Local Conferencing and is the default method of conferencing on the 6757i CT.



Note: Your System Administrator can set your Conference key to speed-dial a specific number. Contact your System Administrator for more information.



IP Phone UI

Use the following procedure to create a conference call using local conferencing. Use the following illustration as a reference.

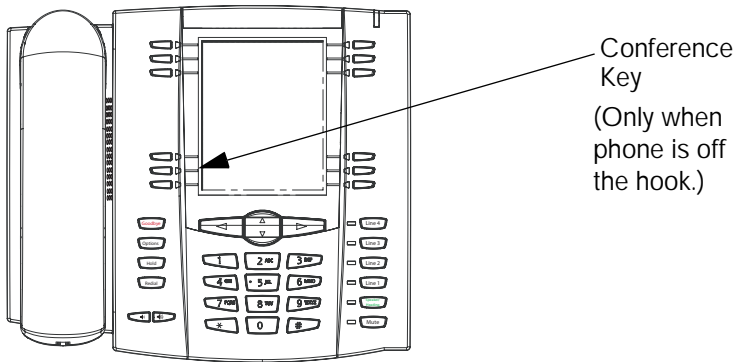

1. When you begin a conference, you are the first party in the conference (Party 1). Pick up the handset or press the speakerphone key. A line opens up.

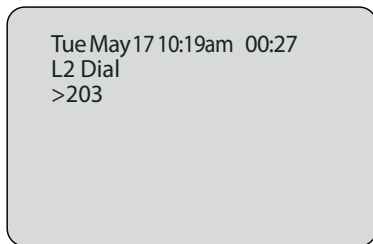

2. Call Party 2 by dialing their number (or answer an incoming call of a Party).
3. Wait for Party 2 to answer. When Party 2 answers, you can consult with them before adding them to the conference.
4. Press the **Conf** Key. A new line opens.

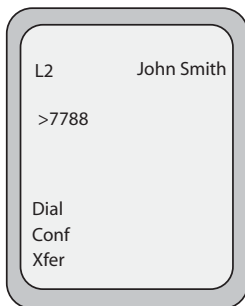

5. Enter the phone number of Party 3.

6. Wait for Party 3 to answer. When Party 3 answers, you can consult with them before adding them to the conference.
7. Press the **Conf** key again to add Party 3 to the conference. Party 1 (which is yourself), Party 2, and Party 3 are all connected to a single conference.
8. To drop a party from the conference, press the **Conf** key once more.



Note: You can use ▲ and ▼ to scroll through and see the numbers and names (if available) of the parties in the conference call. When a name is displayed, pressing ► drops the displayed party from the call.

Joining Two Active Calls in a Single Conference



IP Phone UI

1. Begin with active calls on two different lines (for example, Line 1 and Line 2 have active calls).
2. Press the **Line** key for which you want to conference the two calls together (for example, Line 1).
3. Press the **Conf** key.
4. Press the **Line** key that has the second active call (for example, Line 2).
5. Press the **Conf** key. The two active calls link into a conference call on Line 1.



Note: You can use ▲ and ▼ to scroll through and see the numbers and names (if available) of the parties in the conference call. When a name is displayed, pressing ► drops the displayed party from the call.

Conference Bridge

A key business tool, the conference bridge allows users with an extension and voicemail passwords to schedule and manage conference calls.

Basic functionality includes the ability to create and log into conference bridges. There are also administrator modes that allow calling out and dropping parties from the bridge.

Conference bridge supports up to 20 connected callers. An unlimited number of conference bridges can be in session at the same time.

To Call into a Conference

Internal:

1. Call into the Conference Bridge by pressing **More** then **Conf Bridge** on your phone.
2. Dial **556** from your extension.

External:

1. Call direct DID to Conference Bridge (only if a DID is assigned to Conference Bridge).
2. Call in Auto Attendant and select Menu Option that is assigned to Conference Bridge.* (e.g. Option 4 > Conference Bridge)



Note: Conference Bridge must be configured to one of the Menu Options in the Auto Attendant before accessing from the outside.

Conference Menu Options

Enter a Conference - (Option 1):

1. Enter your extension then press #.
2. Enter conference ID then press #.
3. Please record first and last name then press #.

Create a Conference - (Option 2):

Enter your extension then press #.

Enter your password then press #. (Voicemail Password)

- Create a conference that expires in 2 weeks press **1**
- Create a non expiring conference press **2**
- Create a conference with a custom expiration date press **3**

Delete Existing Conference - (Option 3):

1. Enter your extension then press #.
2. Enter your password then press #. (Voicemail Password)
3. Enter the conference ID you want to delete then press #.

Ending Calls



IP Phone UI

To end a call, you first need to connect or reconnect to the call if not already connected (for example, if your caller is on hold). Press  or the line/call appearance button of the active call to end the call. If connected through the handset, you can also place the handset back on hook to end the call.

Managing Calls

The 6757i CT has several features that make it easier to manage calls, and to keep track of your caller history, as well as your business and personal contacts. These features include:

- Phonebook
- Callers List
- Call Forwarding
- Missed Calls Indicator
- Voicemail

Phonebook

The Phonebook is your personal phone book, conveniently stored within your phone. You can enter up to 200 entries into the 6757i CT Directory by adding them manually, or by saving the number and name from other lists stored on your phone. You can also dial directly from a directory entry. On the 6757i CT, you access the Directory by pressing Key 2 which is the **Directory** key.

Accessing Your Directory



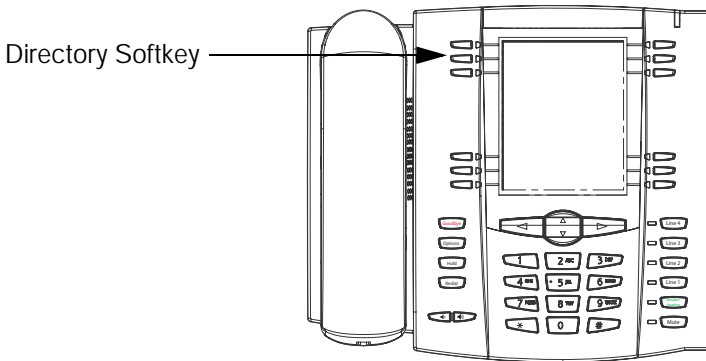

IP Phone UI

Use the following procedure to access your Phonebook. Use the following illustration as a reference.

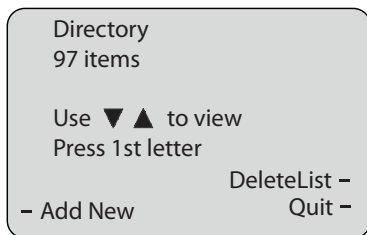

1. Press the **Directory** Key. The directory displays the number of entries in your list. If the Phonebook is empty, **Directory Empty/Use Save to add** displays. The following is an example of the Phonebook header screen with 97 entries in the List.



2. You can access entries by pressing ▲ and ▼ to scroll through the list.
3. To search for an entry by name, press the dialpad number corresponding to the first letter of the name (for example, press 7 for the letter P). Continue to press the dial pad number to access other letters on the same key (for example, press 7 three times for 'Ron'). If there are multiple entries under the same letter, you can use ▲ and ▼ to scroll through the list, or continue to press the next letters of the name to find a better match.
4. To dial the displayed number press  or just lift the handset or press any line keys
5. Press the **Directory** Key to cancel.

Sorting Entries and Quick Search Feature

You can sort multiple numbers according to preference and perform a quick-search feature that allows you to enter the first letter that corresponds to a name in the Directory to find specific line items. The phone displays the first name with this letter.



Note: The quick-search feature in the Phonebook works only when the Directory is first accessed.

Managing the Phonebook

From the Phonebook in the IP Phone UI, you can perform the following:

- Add a new entry
- Edit an entry
- Delete an entry
- Save entries to the Phonebook
 - Save from the Display
 - Save from the Caller List
 - Save from the Redial List

Adding/Editing Entries in the Phonebook

You can store a maximum of 7 numbers associated with a unique name. You can apply pre-defined labels to the entry which include, Office, Home, Cell, and Pager, or create your own labels. The following table indicates the maximum characters for each line and field in the Phonebook.

Phonebook Limitations	
Maximum length of a line	255 characters
Maximum length of a name	16 characters
Maximum length of a label	14 characters
Maximum length of a URI	45 characters
Maximum number of directory entries in the NVRAM	200 entries

The following examples illustrate the IP Phone UI screens you can use to add/edit entries in the Phonebook.

Name
|
Number
Line: 1 ▼ more
- Save
- Backspace
- abc ► Cancel -

Screen 1

Label ▲ more
Office |
- Save
- Backspace Label -
- abc ► Cancel -

Screen 2

Adding Names, Numbers, Labels

On Screen 1:

- You can add names using the **abc** softkey.
- You can add numbers (up to 7 numbers per name) using the numbers on the phone's keypad.
- Use the **Backspace** softkey when required.
- Use the **Save** softkey when you are finished adding the name and number(s).
- You can exit from Screen 1 at any time without saving by pressing the **Cancel** softkey.



Note: Use the ▲ ▼ keys to toggle between Screen 1 and Screen 2.

On Screen 2:

- You can add a label or URI using the **abc** softkey; or you can populate the Label field with a pre-defined label (Office, Home, Cell, Pager) by pressing the **Label** softkey.
- Use the **Backspace** softkey when required.
- Use the **Save** softkey when you are finished adding the Label.
- You can exit from Screen 2 at any time without saving by pressing the **Cancel** softkey.

Editing Names, Numbers, and Labels

On Screen 1, when the cursor is in the **Line** field, softkey 5 displays a **Change** softkey. The following example illustrates a Directory entry for "Steve Smith", with a phone number and an **Office** label. Since the cursor is in the **Line** field, the **Change** softkey displays.



The following example shows the same Directory entry without a label.

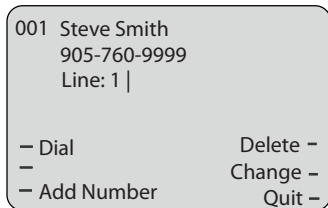

- You can use the **Dial** softkey to automatically dial the number in the Directory entry.
- You can use the **Add Number** softkey to add additional numbers to the

current Directory entry (up to 7 numbers per name).

- You can use the **Delete** softkey to delete a number or to delete multiple numbers in an entry.
- You can use the **Change** softkey to change a number or a name.
- You can use the **Quit** softkey to quit the editing of the current Directory entry.

Scrolling Multiple Screens Per Entry

If there are multiple numbers for an entry, the ◀ and ▶ keys display for you to scroll multiple screens. The following examples show **Screen 1** as Steve Smith's Office number, **Screen 2** as Steve Smith's Home number, and **Screen 3** as Steve Smith's Cell number. The first scroll ▶ indicates there are multiple number entries for the name. The ◀ and ▶ indicates you can scroll forward or backward between screens. The ◀ indicates this is the last number entry for the name.

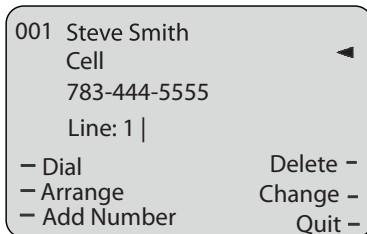
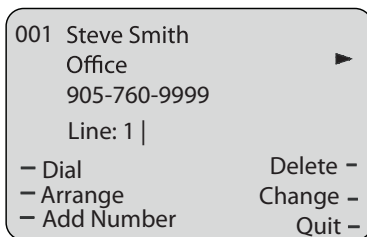

Arranging Multiple Screens

You can use the **Arrange** softkey to move the number/label/line forward or backward between screens for the specified name. If there is a label assigned to the entry, the following screen displays after pressing the **Arrange** softkey.

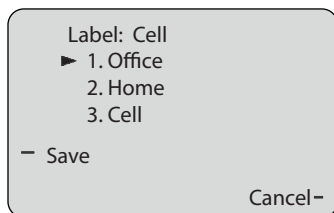

- Pressing the **Save** softkey in the above screen places the Cell label, the Cell number, and line associated with the Cell number, into the first position. So the first screen to display for the entry would be the Cell number screen. If no label is assigned to the entry, the numbers would be arranged in the order you specify.

The following example illustrates the new arrangement of Steve Smith's number.



Note: The **Office** label moves to the second position and the **Home** label moves to the last position.

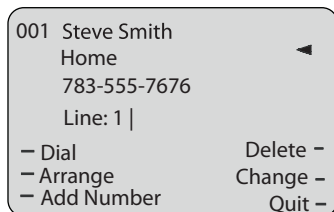
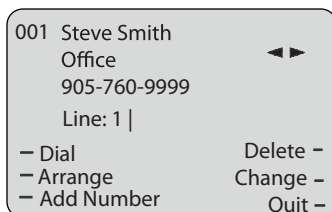
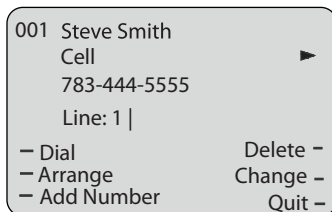

Saving Entries to the Phonebook

You can save entries (names and numbers) from other sources to your Directory using any of the following methods:

- Save from the Display
- Save from the Caller List
- Save from the Redial List

Saving from the Display



IP Phone UI

You can save the name and/or number displayed on your screen during a call to the Phonebook using the following procedure. Use the following illustration as a reference.

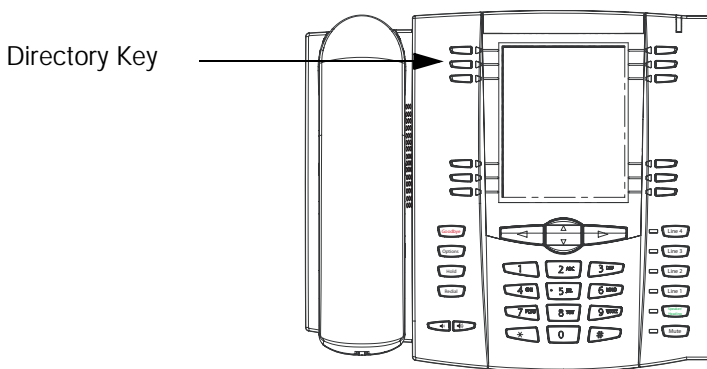

Deleting Single and Multiple Numbers in an Entry

You use the Delete softkey to delete a single number or multiple numbers for an entry. For a single number assigned to a name, pressing the **Delete** softkey displays the following screen.

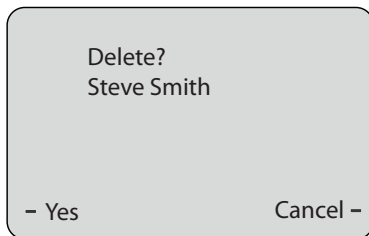

- You can press **Yes** to delete the directory entry (name, number, label, and line) from the Phonebook.
- You can press **Cancel** to cancel the delete function.

For multiple numbers assigned to a name, pressing the **Delete** softkey displays the following screen.

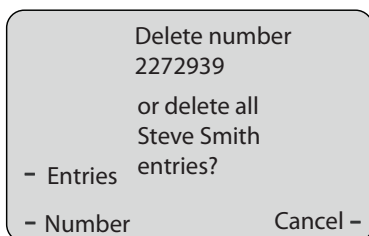

- You can press **Entries** to delete the directory entry (name, all numbers, labels, and lines associated with the name) from the Phonebook.
- You can press **Number** to delete only a specific number associated with a name.
- You can press **Cancel** to cancel the delete function.

The 6757i CT IP phone has a **Phonebook** feature that allows you to store frequently used numbers on the phone. You can also dial directly from a directory entry. You can press the **Dir** key on the idle screen to access the Phonebook.

From the Phonebook in the IP Phone UI, you can add, delete, change, or move entries as required. The following is an example of the Phonebook header screen with 97 entries in the List.

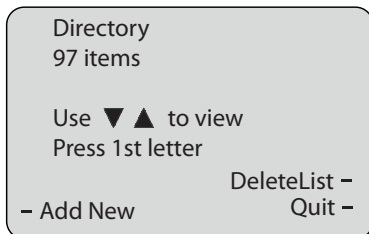

Sorting Entries and Quick Search Feature

You can also sort multiple numbers according to preference and perform a quick-search feature that allows you to enter the first letter that corresponds to a name in the Directory to find specific line items. The phone displays the first name with this letter. The quick-search feature in the Phonebook works only when the Directory is first accessed.



Note: The quick-search feature in the Phonebook works only when the Directory is first accessed.

Downloading the Phonebook to Your PC

You can download the Phonebook to your PC via the Packet8 Web Phone UI. The phone stores the *directorylist.csv* file to your PC in comma-separated value (CSV) format.

You can use any spreadsheet application to open the file for viewing. The following is an example of a Phonebook in a spreadsheet application.

	A	B	C	D	E	F
1	John	41373	2			
2	Tim	41376	1			
3	Carol	4443245	1			
4	Tom	41356	3			
5						
6						
7						
8						
9						
10						
11						
12						

The file displays the name, phone number, and line number for each Directory entry.



Note: Your System Administrator can populate your IP phone Phonebook with server directory files. Contact your System Administrator for more details.

Download the Phonebook

Use the following procedure to download the Phonebook to your PC using the Packet8 Web Phone UI.



Packet8 Web Phone UI

1. Click on **Operation->Directory**.

Status
System Information

Operation
User Password
Phone Lock
Softkeys and XML
Directory
Reset

Basic Settings
Preferences
Call Forward

Directory

Files Available for Download

Directory List

Callers List

Upload Files

2. In the **Phonebook** field, click on . A File Download message displays.
3. Click **OK**.

4. Enter the location on your computer where you want to download the Phonebook and click **SAVE**. The *directorylist.csv* file downloads to your computer.
5. Use a spreadsheet application to open and view the Phonebook.

Accessing the Phonebook

Use the following procedures to access the Phonebook.



IP Phone UI

1. Press the **Services** key on the phone to display the **Services** menu, and select **Phonebook**. or press the **Directory** softkey (default key is key 2 on the Top Keys).
2. Use the ▲ ▼ keys to scroll through the line items in the Phonebook.
3. To dial a displayed entry from the Phonebook, pick up the handset, press the  handsfree key, or press the **Dial** softkey.
4. To exit the Phonebook, press the **Quit** softkey.

Callers List

The Callers List is a stored log of your incoming calls. The 6757i CT telephone stores information up to 200 incoming calls in the Callers List. Your telephone logs the number and name (if available) of the caller, when they last called, and the number of times they tried to reach you.

When the Callers List is full, the oldest call records are deleted to accommodate the information for new callers.

If the telephone number of an incoming or outgoing call matches a number that you have programmed with a name in a softkey or the Directory, the Callers List displays the name and number.

The display shows you how many callers have been added to the list since you last checked it.

Corporate Directory Listing





Use the following procedure to access the Corporate Directory List.

1. Press Directory key and use the arrow keys to scroll to the person for whom you are searching.
2. Press Dial key to initiate the call.

To look up a name in the Corporate Directory Listing:

1. Press Look Up. You can search by First or Last name.
2. Use the arrow keys and the corresponding letter key to enter First or Last name. For example, press 2 three times to produce a "C". You can search for truncated names to select from a list. For example, spell out Wil to search for William, Wilton, etc.
3. Press Look up.
4. Press Select and then Dial to initiate the call.
5. To cancel, press Exit at any time during the process.

Caller's List Screen Display

Display Item	Description
450-349-0438	Indicates you have returned the call from the Callers List.
N MAR 04 3:30pm 2x	"N" indicates a new call.
XX New Callers	When you're not on the telephone and not in the Callers list, the display shows you how many callers have been added to the list since you last checked it.
	Indicates an unanswered call in the Callers List.
	Indicates an answered call in the Callers List.
	Indicates a Call Waiting call in the Callers List.
	Indicates an incoming Call Waiting call.
John Burns 9054550055 Jun 8 2:41pm 2X	"2x" indicates this caller has called twice. The display shows the date and time of the last call from that caller.

You can view, scroll, and delete line items in the Callers List from the IP phone UI. You can also directly dial from a displayed line item in the Callers List.

Accessing the Callers List



IP Phone UI

Use the following procedure to access the Callers List. Use the following illustration as a reference.

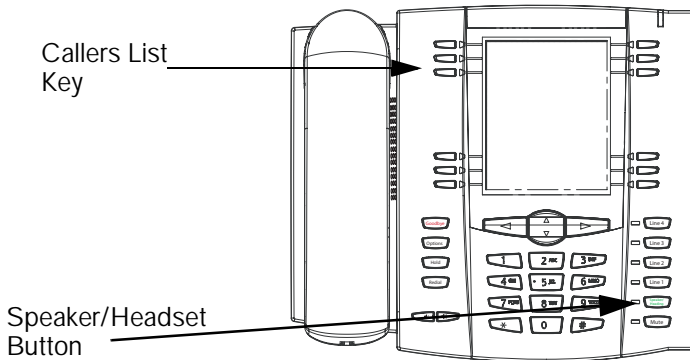

1. Press the **Callers List** key or press the **Services** key if your System Administrator has configured the Services key to access the Callers List.
2. Use the ▲ and ▼ keys to scroll through the line items in the Callers List.



Note: To the left of a line item, a  icon displays with the handset ON or OFF the receiver. The ON receiver indicates the call came in as a missed call. The OFF receiver indicates the call came in and was answered.

3. To delete all entries in the Callers List, press the **Delete** softkey at the **Callers List** header.

To delete a line item from the Callers List, select the line item you want to delete and press the **Delete** softkey.

4. To cancel a delete function, press the ▲ and ▼ **Scroll** keys.
5. To save a line item to a softkey for speeddialing, press the **Save** softkey and enter the line number at the **Save to?** prompt that is already configured for speeddialing at a softkey.
6. To dial a displayed entry from the Callers List, pick up the handset, press the  handsfree button, or press a line key.

7. To exit the Callers List, press the **Callers List** key.

Editing Entries in the Callers List

Important: The Caller List does not save changes. Editing in the Callers List is generally used if you plan to call the number and need to add a prefix.

If a dialpad key is pressed when a number and/or a name is displayed in the Callers List, the cursor automatically adds the digit at the left side of the number to enable the entry of the prefix.

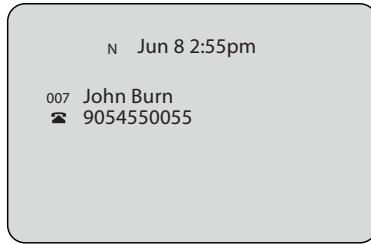

IP Phone UI

Use the following procedure to edit the Callers List. Use the following illustration as a reference.

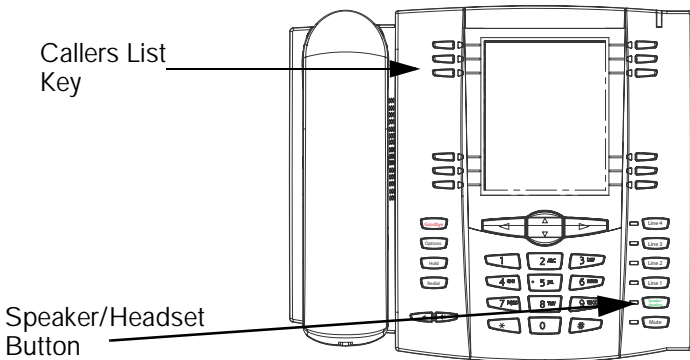

1. Press the **Callers List Key**.
2. Press **▲** and **▼** to find the entry you want to edit. Press **▼** to view the most recent call, or **▲** to see the oldest call on your list.
3. Press any key on the dialpad to begin editing.
4. To move the cursor one digit to the right, press **▶**. To erase one digit to the left of the cursor, press **◀**.
5. To dial the displayed number press , or just lift the handset, or press any line key.

Deleting Entries from the Callers List

You can delete individual items from the Callers List, or you can delete all items in the Callers List.



IP Phone UI

Use the following procedure to delete an individual item from the Callers List. Use the following illustration as a reference.

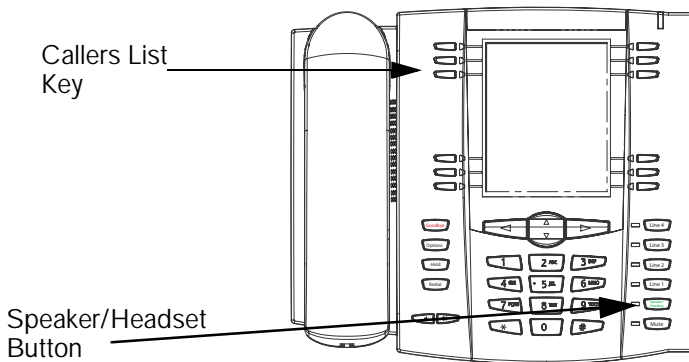

1. Press the **Callers List Key**.
2. Use **▲** and **▼** keys to find the item you want to delete.
3. Press the **Delete** softkey.
4. Press the **Delete** softkey again at the prompt to erase the item.



IP Phone UI

Use the following procedure to delete all items from the Callers List.

1. Press the **Callers List Key**.
2. Press the **Delete** softkey.
3. Press the **Delete** softkey again at the prompt to erase all items.

Downloading the Callers List to Your PC

You can download the Callers List to your PC for viewing using the Packet8 Web Phone UI. When you download the Callers List, the phone stores the *callerlist.csv* file to your computer in comma-separated value (CSV) format.

You can use any spreadsheet application to open the file for viewing. The following is an example of a Callers List in a spreadsheet application. This file displays the name, phone number, and the line that the call came in on.

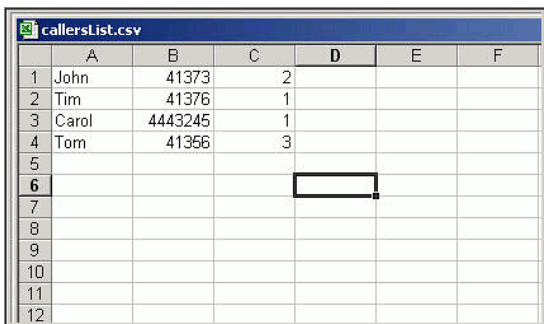

	A	B	C	D	E	F
1	John	41373	2			
2	Tim	41376	1			
3	Carol	4443245	1			
4	Tom	41356	3			
5						
6						
7						
8						
9						
10						
11						
12						

Download the Callers List

Use the following procedure to download the Callers List to your PC using the Packet8 Web Phone UI.

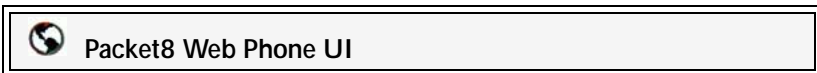

1. Click on **Operation->Directory**.

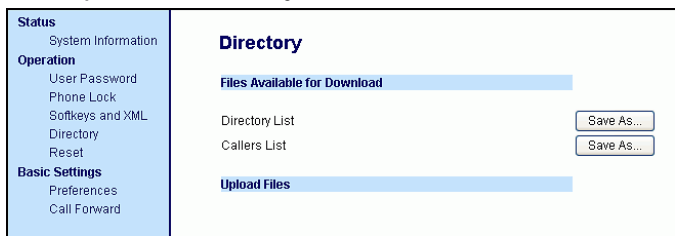

2. In the Callers List field, click on **Save As...**. A File Download message displays.
3. Click **OK**.
4. Enter the location on your computer where you want to download the Callers List and click **SAVE**. The *callerlist.csv* file downloads to your computer.
5. Use a spreadsheet application to open and view the Callers List.

Call Forwarding

The call forwarding feature on the IP phone allows incoming calls to be forwarded to another destination. The phone sends the SIP message to the SIP proxy, which then forwards the call to the assigned destination.

Call forwarding is disabled by default. You can enable call forwarding on a global basis or on an individual line-basis, for each line. If you have configured call forwarding on an individual line, the settings for this line are used; otherwise, the phone-wide call forward settings are used.

You can enable call forwarding on all phones (global settings) or on specific lines (local settings) of a single phone. For local settings, you can set call forwarding on up to 9 individual lines.

For global and local call forwarding, you can set the following:

- Call forward mode
- Destination number
- Number of rings before forwarding the call (from 1 to 9 rings)

The following are the call forward modes you can set:

Call Forward Mode	Description
Off (Packet8 Web Phone UI only)	Disables call forward
All	Phone forwards all incoming calls immediately to the specified destination.
Busy	Phone forwards incoming calls if the line is already in use.
No Answer	Phone forwards the call if it is not answered in the specified number of rings
Busy No Answer	Phone forwards the call if either the line is already in use or the call is not answered in the specified number of rings.



Note: You can set the global call forward settings using the IP phone UI or the Packet8 Web Phone UI. However, you must use the Packet8 Web Phone UI to set the per-line call forward settings. The per-line settings override the settings for global call forwarding.

You can also set global call forward mode from the Packet8 Self Service Portal. Please note that the per-line settings override the Packet8 Self Service Portal settings.

Setting Call Forwarding

Use the following procedure to set global call forwarding.

For Global Call Forward Settings



IP Phone UI

1. Press  on the phone to enter the Options List.
2. Select **Call Forward** and press **Select**.
3. Enter the **Call Forward** number destination for which you want your incoming calls to be forwarded.



Note: If you leave the **Number** field blank, call forwarding is disabled.

4. Select a **Call Mode** that you want to set on your phone using the **Change** softkey.
5. Enter the **Number of Rings** you want to set before the call is forwarded. Valid values are **1** to **9**.



Note: **Number of Rings** field applies to **No Answer** and **Busy No Answer** modes only.

6. Press **Done** to save the settings.

The following example shows the idle screen on the IP Phone with Call Forwarding set to **No Answer** mode.

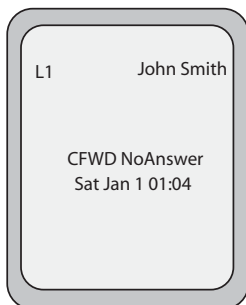



1. Click on **Basic Settings**->**Call Forward**.

Status
System Information

Operation
User Password
Phone Lock
Softkeys and XML
Directory
Reset

Basic Settings
Preferences
Call Forward

Phone-side Call Forward Settings

Global Settings

Mode:

Number:

Number of Rings:

Local Line	Mode	Forward Number	Number of Rings
Line 1	<input type="text" value="Global"/>	<input type="text"/>	<input type="text" value="1"/>
Line 2	<input type="text" value="Global"/>	<input type="text"/>	<input type="text" value="1"/>
Line 3	<input type="text" value="Global"/>	<input type="text"/>	<input type="text" value="1"/>
Line 4	<input type="text" value="Global"/>	<input type="text"/>	<input type="text" value="1"/>
Line 5	<input type="text" value="Global"/>	<input type="text"/>	<input type="text" value="1"/>
Line 6	<input type="text" value="Global"/>	<input type="text"/>	<input type="text" value="1"/>
Line 7	<input type="text" value="Global"/>	<input type="text"/>	<input type="text" value="1"/>
Line 8	<input type="text" value="Global"/>	<input type="text"/>	<input type="text" value="1"/>
Line 9	<input type="text" value="Global"/>	<input type="text"/>	<input type="text" value="1"/>

For Global Call Forward Settings:

2. In the **Mode** field, select the mode you want to set on your phone.



Note: To disable call forwarding in the Packet8 Web Phone UI, set the mode to **OFF** and remove the phone number in the **Number** field.

3. In the **Number** field, enter the call forward number for which you want your calls to be call forwarded.
4. In the **Number of Rings** field, enter the number of rings you want to set before the call is forwarded. Valid values are **1** to **9**.
5. Click to save the Call Forward settings. The changes are global and are immediately applied to the phone.

For Per-Line Call Forward Settings:

1. Select a line to set Call Forwarding on.
2. In the "Mode" field, select the mode you want to set on this line.



Note:

1. To disable call forwarding in the Packet8 Web Phone UI, set the mode to **OFF** and remove the phone number in the "**Forward Number**" field.
2. To force a line to use the global settings, set the "**Mode**" field to **Global**.

3. In the **Forward Number** field, enter the call forward number for which you want your calls on this line to be call forwarded.
4. In the **Number of Rings** field, select the number of rings on the line before the call is forwarded. Valid values are **1** to **9**.
5. Click  to save the Call Forward settings. The changes are global and are immediately applied to the phone.

The following example shows the idle screen on the IP Phone with Call Forwarding set to **No Answer** mode.

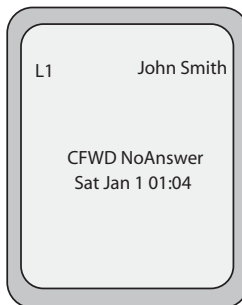

Missed Calls Indicator

The IP phone has a "missed calls" indicator that increments the number of missed calls to the phone. This feature is accessible from the IP phone UI only.

The number of calls that have not been answered increment on the phone's idle screen as **<number> New Calls**. As the number of unanswered calls increment, the phone numbers associated with the calls are stored in the Callers List. The user can access the Callers List and clear the call from the list. Once the user accesses the Callers List, the **<number> New Calls** on the idle screen is cleared.



IP Phone UI

Use the following procedure to access and clear missed calls from the Callers List. Once you display the Callers List, the <number> **New Calls** indicator clears. Use the following illustration as a reference.

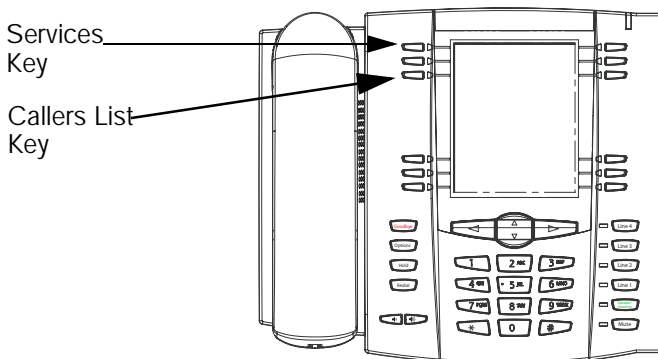

1. Press **Callers List** key on the phone or press the **Services** key and select **Callers List** from the menu.
2. Use the ▲ and ▼ keys to scroll through the line items in the Callers List to find the line items that have the b icon with the receiver ON. These are the missed calls to the phone.
3. To clear a line item from the Callers List, select the line item you want to delete and press the **Clear** softkey. The line item is deleted from the Callers List.

Voicemail System

Virtual Office has a feature-rich, business-class voicemail solution that gives users the ability to manage their calls when not available to answer the phone, by providing callers messaging options. In the voicemail system, users can also route their calls to an alternate number.

To get started, record your first and last name, internal and external greetings, and set your password. Your default password will be nothing. Press # after the prompt asks for a password. It is important to record your first and last name to appear in the dial by name and company directory from the auto-attendant, and one number access greeting.

To Log into Voicemail

Internal

1. Dial the access number 555 or press the **Voicemail** soft key on the Virtual Office Extension.
2. Enter your password then press #.

From another Virtual Office extension

1. Dial 500.
2. Enter your extension number then press #.
3. Enter voicemail Password then press #.

External:

1. Dial your personal DID phone number (not the main company number).
4. Enter # during the voicemail greeting.
5. Enter the voicemail password then press #.

Password Entered Incorrectly: A message saying that the password is invalid is followed by another chance to enter the password. Three password failure attempts will lock the user out of the voicemail system. Hang up and try again. If you continue to have difficulties, call Packet8 tech support with your phone number, email address on file, and problem.



Note: At any time during the menus, you may press the desired keys to interrupt voicemail prompts.

Managing Voicemail

Voicemail can be a powerful tool when you are not available to answer the phone. Different greetings and routing can be accomplished with voicemail. The following section includes listening, saving, deleting, and forwarding message controls, and also includes creating, changing, and setting personal name and greeting options.

Complete Voicemail Menu Tree

To listen to your messages, press 1

Once logging into voicemail, a summary of old and new messages is played, and you will be prompted to proceed. The system will automatically start playing the most recent new message and then the oldest saved messages.

- Press 1 for new messages.
- Press 2 for old and new messages. To replay message, press 1.
 - To listen to next message, press 2.
 - To delete message, press 3.
 - To play previous message, press 4.
 - To call to sender, press 5.

Voicemail Call Return enables you to return a call from voicemail without dialing the number. Simply press **5** while listening to a voicemail, if caller ID is recognized Virtual Office will call the person back. To return to voicemail while still on the call press ***** and you will be returned to that voicemail.

- To return to the main menu, press *****.
- To enable voicemail internationally, contact Tech Support at 1.888.898.8733
 - Press **3** for group messages (this prompt is only played if you belong to a group extension).
 - For the main menu, press *****.

To establish or change a greeting, press 2

- To record your first and last name, press **1**. (This will be the name that callers hear if they select Dial By Name or Company Directory from the Auto Attendant. If no name is recorded, your name will not be heard on the company auto-attendant directory.)
- To record your internal greeting, press **2** (played only to internal callers).
- To record your external greeting, press **3** (played only to external callers).
- To record your after business hours greeting, press **4**.
- To record your lunch time greeting, press **5**.
- To record your meeting greeting, press **6**.
- To record your weekend greeting, press **7**.
- To record your vacation greeting, press **8**.
- To return to the previous menu, press *****.
- To exit, press **9**.

To change user preferences, press 3

- Password **1**.
- Do not disturb **2**.
- Call waiting **3**.
- Busy, ring no answer, Internet outage handling **4**.
 - Email notification **6**.
 - To return to the previous menu, press *****.

To establish or change forwarding rules, press 4

- Listen to forwarding rule, press **1**.
- Change forwarding rule, press **2**.
- To set forwarding rule, press **3**.
- To delete forwarding rule, press **4**.
- To return to main menu, press *****.
- To exit, press **9**.

To set a specific greeting to play, press 5

- Business hours greeting, press 1.
- After business hours greeting, press 2.
- Lunch time greeting, press 3.
- Meeting greeting, press 4.
- Weekend greeting, press 5.
- Vacation greeting, press 6.
- To listen to the current greeting, press 0.
- Return to the previous menu, press *.

To turn on/off the announcement only mode, press 6

To exit, press 9

To place a call from voicemail press #

Calling out of voicemail enables users to take advantage of Packet8 competitive international rates by dialing any number from inside voicemail. While accessing your voicemail, press * then press #. You will hear dial tone. Press 9 and dial the number to initiate your call. If on a cellular or mobile phone, you can access our low international calling rates by dialing into your voicemail to originate call.



Note: Contact Packet8 Tech Support to enable this feature.

Message Playback Control

When listening to messages, the system gives the user several options:

- To hear more options, press 0.
- Press 1 to obtain more information about the message. The following will be heard:
 - External or internal message
 - Priority type
 - From Caller ID or extension
 - Timestamp for message.
- Press 2 to forward the message to another extension.
- Press 3 to call the sender.
- Press * to return to main menu.



Note: At any time during the menus, you may press the desired keys to interrupt voicemail prompts.

Forwarding Messages

1. A user can forward a message to another user to share information.
2. Log into voicemail and select the message that is to be forwarded.
3. Press 0 after listening to the message.
4. Select 2 to forward message.
5. Enter the extension numbers where the message should be sent.

Personal Voicemail Greetings

Virtual Office allows an array of greetings to be recorded for different activities. Users can select which greeting callers will hear when they are not able to answer a call.

To Record Your Greetings into Voicemail

From voicemail's main menu, select 2 and then follow the prompts to record each greeting personally.

- To record your first and last name, press 1.



Note: It is important to record your first and last name to be listed in both the dial by name and the company directory from the auto-attendant and one number access greeting.

-
- To record your internal greeting, press 2.
 - To record your external greeting, press 3.
 - To record your after business hours, press 4.
 - To record your lunchtime greeting, press 5.
 - To record your meeting greeting, press 6.
 - To record your weekend greeting, press 7.
 - To record your vacation greeting, press 8.

Selecting the Voicemail Greeting to Play

From the voicemail main menu, select 5 and then follow the prompts to select which greeting callers will hear.

- Business hours greeting, press 1.
- After business hours greeting, press 2.
- Lunch time greeting, press 3.
- Meeting greeting, press 4.
- Weekend greeting, press 5.
- Vacation greeting, press 6.

Cordless Handset

The following sections describe the 6757i CT cordless handset keys and key functions, and how they help you make and manage your calls and caller information.

Handset Keys

The following illustration and table identify the keys on the key panel of your 6757i CT handset that you can use for handling calls.

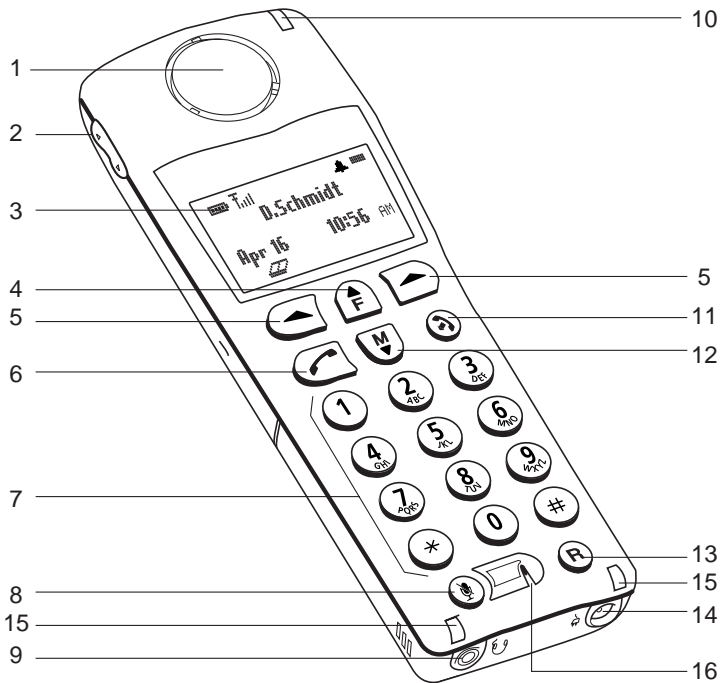

Handset Key Descriptions

Function #	Function Description
1	Receiver
2	Volume key During Ringing: Adjusts ringer volume During a call: Adjusts receiver volume During text mode (not in a call): Moves cursor right/left
3	Display
4	Features f Key List Access key to the programmed Feature Key List Scrolls up when in the various lists Adds a space during editing
5	Softkeys Activates feature or option shown on the display above the keys
6	Call key Used to obtain dial tone Also used as a Hold key
7	Dialpad
8	Mute Key When used, prevents the caller from hearing you
9	Headset Jack
10	Status Light
11	Release key To end calls and go on hook Exits Menu and the various lists
12	Menu Key Access key to the different Options Scrolls down when in the various lists Used as Backspace during editing
13	Redial Key Displays the last 10 numbers dialed
14	Charging Jack
15	Charging Contacts
16	Microphone

When in an idle state, pressing the Menu key $\bar{\Delta}$ of the handset presents the following list of options. Once in the menu list the user can scroll up $\bar{\uparrow}$ and down $\bar{\Delta}$ using the scrolling keys to see each option.

Item #	Menu list
1	Intercom
2	Language
3	Ring tone
4	Custom name
5	Timer Off
6	Vibrate Off
7	Handset pairing
8	Key lock Off
9	Backlight Off
10	Silent Alert



Note: The display returns to idle if no action/activity is initiated within 20 seconds.

Accessing Options on the Handset

Pressing the $\bar{\Delta}$ key accesses the **Options List** menu. This action results in displaying a Menu list header with brief list navigation instructions.



Navigation of the menu is performed using the down arrow ($\bar{\Delta}$ key) or the up arrow ($\bar{\uparrow}$ key). Shortcut to the menu item can also be performed by pressing the corresponding menu item number. You can press a two digit numbered item within a one second time span as a short cut to select the item.

Pressing the γ key quits the Menu and return to the idle mode or call mode.

Intercom

The 6757i CT supports Intercom function between a 6757i CT base and any of its paired cordless handsets, and vice versa.

Pressing **Select** while viewing this option brings up a list of base and paired handsets available for Intercom. To select a handset or base to Intercom, navigate to the desired handset or the base using the **▲** key or the **▼** key. Then press the Call softkey. Shortcut to any handset or base in the list is permitted by pressing the corresponding numeric key digit; the order of the list is numbered from zero (0) for the base and four (4) for the 4th handset in the list.



Note: Your System Administrator can configure outgoing Intercom calls using the Icom button. Contact your System Administrator for more information.

Reference

For more information about using the Intercom feature, see ["Using Intercom"](#) on page 78.

Ring Tone

There are several selectable Ring tones available on the 6757i CT handset. A check mark beside the ring tone number indicates the currently selected ring tone.



Reference

For more information about selecting a ring tone on the handset, see ["Ring Tones and Tone Sets"](#) on page 25.

Custom Name

Custom name allows the user to personalize the name/label for the cordless handset. In a multi-handset environment, this is an ideal option to personalize each handset to its user or extension number.



Handset UI

1. Press **Å** .
2. Navigate to **Custom Name** or press **4** .
3. Press the **Change** softkey.
4. Press the **Edit** softkey. If a custom name already exists, the **Delete** softkey is presented.
5. Using the keypad, type out a new label or use the scroll keys **Ï** and **Å** to move the cursor to the desired display position or to erase text.
6. The **ChCase** softkey is available to toggle between upper and lower case text entry.
7. Press the **Save** softkey to save the name.
8. Press the **Goodbye y** key to return to the main idle screen.



Note: In editing mode, the Volume Bar can be used in place of the **Ï** and **Å** keys to control the screen cursor. Pressing the Lower end volume bar for Backspace/Erase; and pressing the Higher end volume bar to add a Space.

Call timer

When the call timer is enabled, the timer starts from the first call and continues until all calls have been released.



Note: The call timer is not usable for call accounting since the timer continues to increment even when the call is on hold.

Vibrate

The Vibrate option allows the handset to signal an incoming call by vibrating as well as ringing. By default, this option is always Off.



Handset UI

- To enable this feature, press the **Change** softkey. The display indicates "**Vibrate On**" and "**-confirmed-**" and quickly returns to the previous menu display.
- Once the Vibrate is On, **p** icon is shown beside the ringer icon on the top right line of the display.
- Pressing the **y** key returns you to the main idle display screen.

Handset Pairing

All handsets must be paired to a 6757i CT base before it can be used. For more information on pairing the handset, see "[Pairing and Unpairing Cordless Handset to Base](#)" on [page 133](#).

Key Lock On or Off

The key lock option enables the user to lock the keypad keys. This prevents accidental activation of the phone.



Handset UI

To lock the keys from the key lock option page:

- Press **Change** softkey to turn Key lock ON or OFF. The screen displays **Key lock On** or **Key lock Off -confirmed-**.
- Pressing the **y** key returns you to the main idle display screen.



Note: You can activate the Key Lock Off or On by pressing only the **Å** and then the ***** key from the idle screen.

Backlight

The Backlight option allows the user to turn on or off the backlit light on the LCD display.



Handset UI

- Press **Change** softkey to turn Backlight ON or OFF.

Once the Backlight option is chosen, the screen displays **Backlight On** or **Backlight Off -confirmed-**.

Silent Alert

The Silent Alert option activates an internal hardware vibrator instead of a regular ringer during an incoming call. By default, the Silent Alert is automatically set to Off.



Handset UI

To activate Silent Alert from the option display:

- Press **Change** softkey to turn alert On or Off. The display shows **-confirmed-**.

Once the Alert is On,  icon is shown on the top line of the display.



Notes:

- 1.You can activate or deactivate the Silent alert by pressing only the **Å** key and then the **#** key.
- 2.The Ringer Icon does not appear on the display when the Silent alert is On.

Finding the Phones IP Address using the Handset

You can find the IP address of the IP phone's Base Unit using the handset. Use the following procedure to find the IP address.



Handset UI

1. Press the **Å** key to enter the Options List when the phone is not in use.
2. Use the scroll keys **Å** and **Ī** to scroll to the **Network** option.
3. Press **r** to select the **Network** option.
4. Use the scroll keys **Å** and **Ī** to scroll through the network status until the IP address of the phone appears in the display.
5. Press **y** when done.

Feature Keys on the Handset

You can program up to 15 feature keys on the 6757i CT handset with specific functions using the Packet8 Web Phone UI. The following table identifies the functions available for all 15 handset keys and the default functions for each key.

Key Function	Description	Default for:
Line 1	Line 1 key - Selects line one	Handset Key 1
Line 2	Line 2 key - Selects line two	Handset Key 2
Line 3	Line 3 key - Selects line three	Handset Key 3
Line 4	Line 4 key - Selects line four	Handset Key 4
Icom	Intercom key – Enter handset list to select handset to call	Handset Key 5
Dir	Directory key – Activate directory feature	Handset Key 6
Callers	Callers key – Activate callers feature	Handset Key 7
Xfer	Transfer key - Activate transfer feature	Handset Key 8
Conf	Conference key - Activate conference feature	Handset Key 9
Public	Public key – Toggle between public & private call mode	Handset Key 10
None	No function is selected – this key is empty, no label	Handset Key 11 and 12
Line 5	Line 5 key (if available) - Selects line five	Handset Key 13
Line 6	Line 6 key (if available) - Selects line six	Handset Key 14
Line 7	Line 7 key (if available) - Selects line seven	Handset Key 15
Line 8	Line 8 key (if available) - Selects line eight	
Line 9	Line 9 key (if available) - Selects line nine	

Feature Key Programming Guidelines

The following are guidelines to use when programming the feature keys on the handset:

- All handsets paired with the same Base Station have the same programmed functions since the web interface applies the functions to all the handsets paired with that base.
- A newly registered handset or handset that was out-of-range during the programming needs to perform an "off-hook and on-hook" sequence in order for the newly programmed function to be broadcast to the affected handsets. Simply press the \checkmark key from the idle state to go off-hook. Then, press the y key to go back on-hook.
- Duplicate functions can exist in the feature key as there is no filtering or duplicate checking done on the handset or the base.

- If no line keys are programmed for the feature key, the handset is restricted to Intercom calls only.
- If all 12 programmable functions have been programmed to **None**, the user is presented with a **List empty** message when the feature key is pressed.



- For security reasons, the user has 180 seconds (3 minutes) to complete the programming. Otherwise, the phone displays the following error:
**** Error **: Session expired, Please reload page.**
- For security reasons, the user must submit the page from the same browser that was used to load the page. If the user tries to submit the page from any other IP address, the following error displays:
**** Error ** Session invalid. Different Client IP Addresses. – Please reload page.**

Programming Feature Keys

You can program up to 15 feature keys on the 6757i CT IP phone using the Packet8 Web Phone UI. Use the following procedure to program the feature keys on your 6757i CT Base Station and all paired handsets.



Packet8 Web Phone UI

1. Open your web browser and enter the phone's IP address or host name into the address field.
2. At the prompt, enter your username and password and click .



Note: For a user, the default user name is "user" and the password field is left blank

3. Click on **Operation->Handset Keys**.

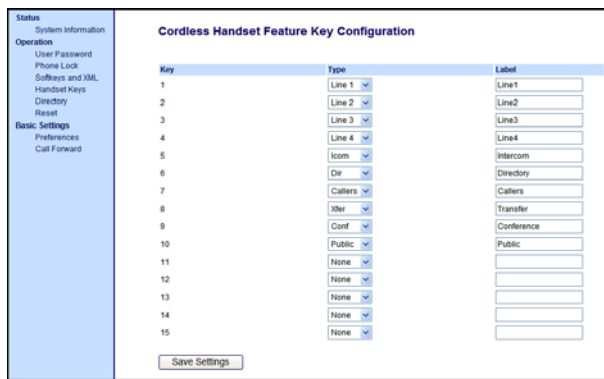

4. Select the handset key you want to program.
5. Select the function for that handset key from the **Key Function** field.
6. Click to save the function you selected to the handset key. The key programming information is sent to the 480i Base Station and to all the cordless handsets associated with that Base Station. Any key programmed to **None** does not appear in the handset's list.

Idle Mode

During idle mode (i.e. no incoming call, no active call, or no call on hold), the handset name, date & time, status messages, and status icons are present on the display.





Note: The phone name label (Angela in the diagram above) can be edited in the Options list.

Handset Icons and Status Messages

Screen Icons

Icon	Description
b	Battery Charge State 4 bars for battery full and the battery icon flashes when charging.
m	Reception (Radio Link) On - Within Range: Ready for use OFF - Out of range/no radio link
h	Feature Key Activation Indicates the phone is off hook or a call is in progress.
p	Silent Alerter Silent alerter activated
~ b	Ringer Volume This icon is available only when the phone is in idle mode to indicate the ringer volume level. The box goes from empty to fully black to represent from off to low to high volume.
l b	Receiver Volume This icon is available only when the phone goes off-hook to indicate the receiver audio volume. The box goes from empty to fully black to represent from low to high volume; there are 10 volume levels total.

Icon	Description
	Phonebook This icon located just above the softkey allows access to the Phonebook feature.
	Callers List This icon located just above the softkey allows access to the Callers List feature.

Status Messages

Display Message	Description
Microphone mute	Indicates when the Mute button has been Activated
Out of range	Appears briefly when pressing a key if out of range of the base station

Multifunction Handset LED Indicator

The multifunction Handset LED provides the following user feedback:

- **Flash: Message Waiting Indicator** – Slow
- **Flash: Alerting** – Rapid
- **Flash: Mute** – intermittent
- **Flash: Hold** – Intermediate
- **Solid:** On an active call

Handset Keys

Softkeys ({ or })

Your 6757i CT cordless handset has two softkeys directly under the LCD display. The softkey menus change depending on the phone's state, displaying relevant softkeys only. These softkeys are pre-programmed for the call handling and extension management features.

Talk /Hold Key

The Talk/Hold key  is a multi-purpose key with the following uses:

- To initiate a call by seizing the line or through pre-dial.
- To answer a call during ringing.
- To place a call on hold during an active call.

Hold √ Key

- Press the hold key √ while on a call to place the call on hold. While a call is on hold, and if there are no other active calls, the LED flashes at the hold rate and the display presents the **Call is on Hold** prompt. In addition, a held call reminder tone is played in the form of a short ring burst (flash ring).



Note: The handset is equipped with an auto-hold feature. While on an active call, pressing any other line key results in the current line being placed on hold and the new line being seized.

Release Key (y)

The release key is a multi-purpose key with the following uses:

- To end a call.



Note: You can also place the handset in the charger cradle to end the call.

- To silent the ringing during an incoming call.
- To exit feature such as Menu (options), Directory, Callers, Redial or Predial.



Note: Pressing this key in a feature does not terminate an active call.

Mute Key (æ)

Use the mute key when you want to be able to hear a caller but have them not hear you. Press the æ key to mute the handset. Press the æ key again to disengage mute. The "Microphone Mute" prompt displays when mute is activated.

Redial Key (β)

The Redial key displays a list of the last 10 calls made from the handset. Use the ĩ and Å to scroll through the list.

Feature Key List (ĩ)

The 6757i CT cordless handset supports a programmable feature key list for easy access to common features. The available features include line keys, Intercom, directory, callers log, transfer, conference, and public/private call mode. For more information about the feature keys, see "[Feature Keys on the Handset](#)" on [page 120](#).

Menu List (Å)

The Menu list allows access to Intercom calling, and personalization of handset including ring tone, vibrate, backlight and silent alert. Please refer to the section, "[Accessing Options on the Handset](#)" on [page 115](#).

Battery Charging

The handset is powered by a nickel metal hydride battery pack. To install and charge the battery:

1. Slide the cover of the battery compartment.
2. Place the battery pack in the compartment with the connector wires pointing towards the bottom of the handset.
3. Connect the battery terminal wire to the charging pins located in the compartment.
4. Slide the cover of the battery compartment back onto the handset.
5. Place the handset, face up, in the charging cradle. The handset should easily slide into the charging cradle. If it does not, check the battery compartment cover to ensure it is in the proper position.

To confirm that the battery is charging, check the battery icon symbol on the handset display to see if the lines inside the icon are flashing left to right.



Note: The battery must be charged for a minimum of six hours prior to initial usage of the phone.

Handset Battery Indicator & Status

The display provides "at a glance" information on the handset battery.

Icon	Description
d c b a	The bars indicate the battery charge level – 4 for full, needs recharging when only 1 bar appears.
f	The bars flash when the battery is being recharged on the charger stand.



Note: The handset is designed to recharge the batteries automatically, when required and placed on the charger stand. The battery icon does not flash and the handset does not charge every time it is placed on the stand. If a defective battery is replaced, the battery icon is not identified until the new battery is charged for at least 2 minutes.

Volume Control

The volume key, located on the side of the handset, controls both the receiver and ringer volume.



Note: The Volume key can also be used to adjust the right/left cursor to add spaces or to erase characters on the display when editing or creating names, key labels etc.



Handset UI

To adjust the receiver volume:

- While on a call, press the top of the key to increase the receiver volume and press the bottom of the key to decrease the volume. The receiver volume icon indicates the current volume level. In absence of a PBX, the receiver volume returns to the default setting after each call. However, the PBX directive can direct the handset default to the volume.

To adjust the ringer volume:

- When the handset is not being used for a call, press the top of the key to increase the ringer volume and press the bottom of the key to decrease the ringer volume. The handset ringer sounds on each adjustment to reflect the new setting and the ringer volume icon shows the current level chosen.

Directory – Cordless Handset

Entering Characters and Numbers in the Directory

Editing keys

During alphanumeric entry, the volume control keys become edit keys. They provide backspace and forward-space capability to the unit. For Backspace/Erase, press the Lower end of the volume bar. To add a space or to erase from left to right, press the Higher end of the volume bar.



Note: The Down scroll key (marked $\bar{\Delta}$) or the Up scroll key (marked $\bar{\nabla}$) are also used to provide backspace and forward space respectively.

General Record Editing

To accommodate adding and editing, use the available characters as labelled on the keypad. Pause key and special characters are also available:

○ Key / Pause key

To allow the user to enter pause characters, the pause key is the ○ digit key in alphanumeric editing mode. Characters appear in the following order: 0, p.

1 Key

In the alphanumeric mode, the 1 digit key accesses several special characters. Characters appear in the following order:

1	@	.	:	;	=	-	,	-	`	&	()
---	---	---	---	---	---	---	---	---	---	---	---	---

As can be seen, these special characters are accessible through the 1 key allow URI and IP address data entry.



Note: To enter the dot/period in the IP address format, the star * key is used when in numeric "123" editing mode. Alternatively, in text "abc" or "ABC" editing mode, use the 1 key to access the ".".

"123" –p"abc"p–"ABC" softkey

You can use the left softkey to toggle from numeric "123" editing mode to lower case text "abc" editing mode, to upper case text "ABC" editing mode.

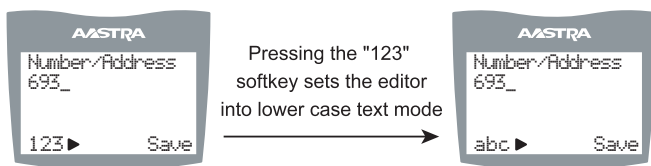

Switch from Numeric to Lower Case Alphanumeric Mode

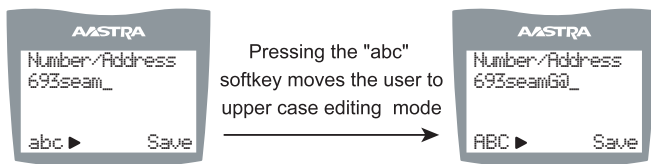

Continued Editing in Lower Case Text mode Then Switch to Upper Case Text Mode

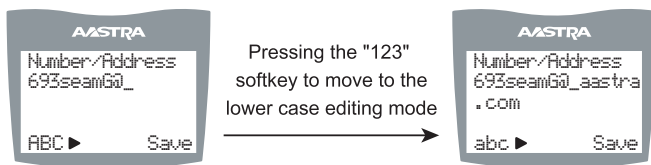

Cycle Edit Mode Back to Lower Case and Finish Address Entry

Adding a Record to the Directory

The directory can store up to 50 names and numbers, which display in alphabetical order. If no name is entered, the entries are sorted by number, at the beginning of the directory.



Handset UI

To add an item to the directory:

1. Press the  key from the idle mode as shown below.



2. Press the **Add** key.



3. Enter the Number/Address information. For more information on entering characters/numbers in the Directory, see ["Entering Characters and Numbers in the Directory"](#) on page 126.
4. Press **Save** to advance to the name entry screen.



Pressing "Save" softkey moves to the name editing mode



5. Enter a name for the Number/Address information. The name can have up to 15 characters, including spaces. For more information on entering characters/numbers in the Directory, see ["Entering Characters and Numbers in the Directory"](#) on page 126.
6. Press the **Save** softkey. The display shows **Item Saved**.

Callers List - Cordless Handset

The Callers list stores the last 50 calls received. Items are stored in chronological order with new items being first in the list. Each call received is stored, no collapsing of records, and can be deleted or saved to a directory. Oldest call records are automatically removed from the list when the list is full and new items are received.

The following figure shows the header screen. On this screen, there is the title, the number of total items, the number of new items, instructions for viewing the items and two softkeys – **Exit** and **Delete**. The **Exit** key quits the list and the **Delete** key deletes the entire Callers list.



If there are no new items, then the **x New** line is not displayed. Once items are viewed, they are marked as old and do not show up in the new item count or in the new item scroll List.

Once in the list, items are displayed as shown in the next figure.

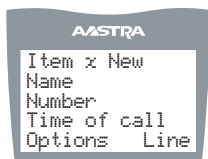

The above screen shows the item number, the name and number of the caller, and the time the call was received. Also shown are two softkeys – **Options** and **Line**.

Options allow the user to save to directory or delete the record.

Dialing from Callers List



Handset UI

1. To dial a caller back, press the **Line** softkey. You are taken to the feature list where you can choose the configured line to place the call.
2. Scroll to the desired line and press **Select**. The call is placed on that line over the cordless link.

Saving Item to Directory



1. From the **Options** softkey in the Callers List, scroll to the **Save to Directory** Item.
2. Press the **Select** softkey. The following screen displays upon successful saving to the directory.



Deleting Item from Callers List

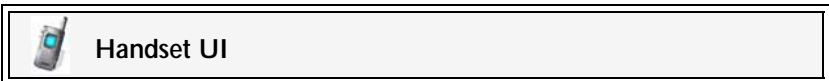

1. From the **Options** softkey of the Callers List, scroll to the **Delete Item**.
2. Press the **Select** softkey.



You are prompted to confirm the delete action by pressing the **Delete** softkey.



3. Press **Delete** to remove the item.

Making Calls from Cordless Handset

Pre-dialling a Number



Handset UI

1. Press the **v** key to obtain dial tone and use the Keypad to dial the number. You can also make a call by pre-dialling a number. Pre-dialling lets you view a number before you dial.
2. If the number is correct, press the **v** key to dial the number.
3. If the number is incorrect, use the **Ã** key or press down on the volume key to erase digits from right to left. Calls can also be made directly from the Directory.

Using a Headset

The 6757i CT cordless handset accepts headsets through the 2.5 mm audio jack on the bottom of the phone. Contact your telephone equipment retailer or distributor to purchase a compatible headset, or go to www.Packet8.net/store. Customers should read and observe all safety recommendations contained in headset operating guides when using any headset.

Receiving Calls



Handset UI

- When a call is ringing at your extension, the handset displays the **Inbound Call** screen.
- Press the **v** key to answer an incoming call or lift the handset out of the charging cradle.

Call Privacy

In the 6757i CT multi-handset system, it is possible to connect several cordless handsets together with each other or with the base as extensions to a call. This is just like an analog system with extension phones going off hook to join a call in progress. However, because this system is actually intended for use in an enterprise environment, some method of call privacy is required.

All calls, base or handset, begin in the private mode. In this mode, no extensions are allowed to join that handset or base call. A user interface provides the ability to toggle between the **Private** and **Public** modes. See the next section for information about using the **Public** and **Private** keys.

Public Feature Key

A feature key is available in the feature list for the user to press, to toggle between the **Private** and **Public** modes for a call. Pressing the **Public** feature key in the feature list anytime during a call, puts the call into the public call mode. When the call is in public call mode, the triangle indicator lights in front of the **Public** label in the feature list. This also causes that feature key to appear on an available softkey but with a different label – **Private**. The user can then press the **Private** softkey to toggle the call back to private, or he can navigate into the feature list and press the **Public** feature key.

Either way, the triangle indicator clears and the call goes back to **Private** mode. The following illustrations show the handset screens during public and private calling.



Private Call in Progress



Feature List View with the Public Key Selected but not Invoked



Public Call in Progress

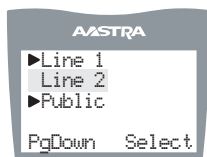

Feature List View with the Public Key Invoked but not Selected

In the figure above, the left screen depicts a call that is public. The user can press the **Private** softkey at any time to make the call private – i.e. no extensions are allowed to join. In the right screen, the right pointing triangle indicates the current call is in public mode. The user could also select this feature key to return the call to private.



Note: Any local caller on the call can convert the call. For instance, if one cordless caller is on an external call, he can press the **Public** feature key to make the call public. At that point up to three other handsets can join in on the call. If any of those joining handsets presses the **Private** softkey, the call is made private and no other users can join the call unless the call was made public again.

Ending Calls



Handset UI

- To end a call, you first need to connect to the call, if not already connected, and press the  key.
- You can also place the handset back on the charging cradle to end the call.

Pairing and Unpairing Cordless Handset to Base

Pairing Handset

All handsets must be paired to a Base Station. This is performed from both the base and the cordless handset. Successful pairing adds the handset name to the handset list on the base and synchronize the handset list from the base to the newly paired handset. A total of 4 handsets can be paired to a single 6757i CT base.



Note: When performing the handset pairing, it is recommended that the handset be within 3 feet of the 6757i CT base.



Handset UI

1. On the 6757i CT base unit press .
2. Select **Preferences**.
3. Select **Handset Pairing**.

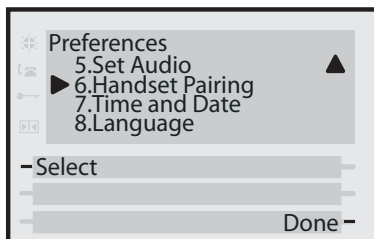

4. Select Pair.

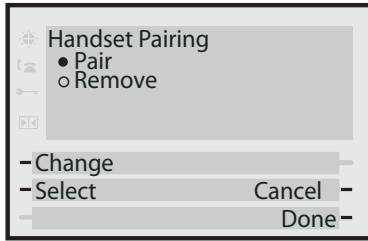

Note: If there are already 4 handsets paired to the base, you cannot select the Pair option.

5. On the 6757i CT cordless handset press \hat{A} .

6. Select Hset Pairing.



Note: If the handset has already been paired, the softkey is labelled as Remove instead of Pair.

Ensure the handset being paired is within close proximity to the base. It is recommended that the handset be within 3 feet from the 6757i CT base.



Note: It is recommended that both steps 6 and 7 be executed at the same time.

7. On the 6757i CT base, select Done.

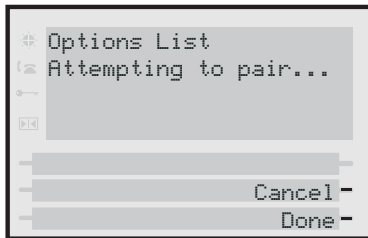

8. On the 6757i CT cordless handset, press the softkey for Pair.



Upon success or failure of pairing, one of the following displays on the handset and base, respectively:



Successful Pairing of Handset



Failed Pairing of Handset

Unpairing Handset

Unpairing of the handset can be done from either the cordless handset or the base. However, if the handset being removed is out of range from the base, the unpairing is only performed local to the device where the removal process was initiated.

If the unpairing is only successful from the local device, the unpairing procedure needs to be completed from the other device.



Handset UI

1. On the 6757i CT base press .
2. Select **Handset Pairing**.

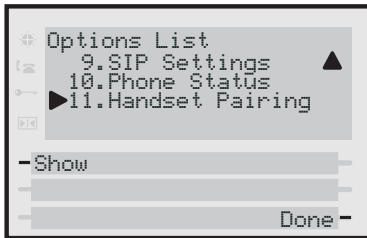

3. Select **Remove**.

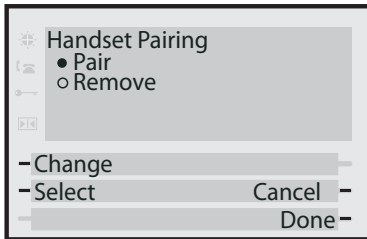

4. Select **Done**. The following screen displays on the base phone.

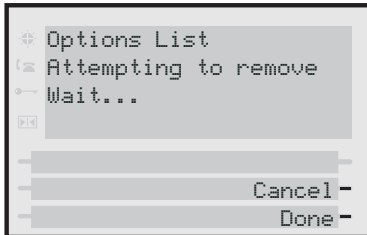

Upon success or failure of unpairing, one of the following screens displays on

the base phone.

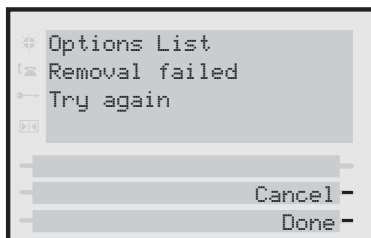

Failed Removal

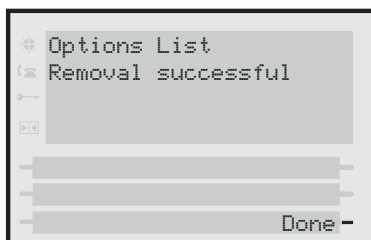

Successful Removal

5. If required, on the 6757i CT cordless handset press \tilde{A} .
6. Select **Hset pairing**.



Note: If the handset is not paired, the softkey is labeled as **Pair** instead of **Remove**.

7. Press the **Remove** softkey.



Upon success or failure of unpairing, one of the following screens displays on

the handset.



Successful Removal Attempts



Failed Removal Attempts



Note: Unpairing of the handset returns it to factory default state. All data including the functions in the Feature key are removed.

Additional Features

This section describes additional features you can use on the 6757i CT phone.

Suppressing DTMF Playback

A feature on the IP phones allows you to enable or disable the suppression of DTMF playback when a number is dialed from the softkeys.

When suppression of DTMF playback is disabled, and you press a softkey, the IP phone dials the stored number and displays each digit as dialed in the LCD window.

When the suppression of DTMF playback is enabled, the IP phone dials the stored number and displays the entire number immediately in the LCD window, allowing the call to be dialed faster.

DTMF playback suppression is disabled by default. Suppressing DTMF playback can be configured using the Packet8 Web Phone UI.



Use the following procedure to configure suppression of DTMF playback.



Note: Suppress DTMF Playback is disabled by default.

1. Click on **Basic Settings**->**Preferences**.

Status	System Information
Operation	
User Password	
Phone Lock	
Softkeys and XML	
Directory	
Reset	
Basic Settings	
Preferences	
Call Forward	

Preferences	
General	
Park Call:	<input type="text"/>
Pick Up Parked Call:	<input type="text"/>
Suppress DTMF Playback	<input type="checkbox"/> Enabled
Display DTMF Digits	<input type="checkbox"/> Enabled
Play Call Waiting Tone	<input checked="" type="checkbox"/> Enabled
Stuttered Dial Tone	<input checked="" type="checkbox"/> Enabled
XML Beep Support	<input checked="" type="checkbox"/> Enabled
Status Scroll Delay (seconds)	<input type="text" value="5"/>
Incoming Call Interrupts Dialing	<input type="checkbox"/> Enabled
Goodbye Key Cancels Incoming Call	<input checked="" type="checkbox"/> Enabled

2. Go to the **General** section.
3. Enable the **Suppress DTMF Playback** field by checking the check box. (Disable this field by unchecking the box). Default is disabled.
4. Click  to save your settings.

Display DTMF Digits

A feature on the 6757i CT phone allows users to enable or disable DTMF (dual-tone multi-frequency) digits to display to the IP phone when using the keypad to dial, or when dialing from a softkey.

DTMF is the signal sent from the phone to the network that you generate when you press the phone's touch keys. This is also known as "touchtone" dialing. Each key you press on your phone generates two tones of specific frequencies. One tone is generated from a high-frequency group of tones and the other from a low frequency group.

If you enable the Display DTMF Digits parameter, the digits you are dialing from the keypad or from a softkey display to the IP phone's LCD display. This parameter is disabled by default (no digits display when dialing).

You can enable the **Display DTMF Digits** parameter using the Packet8 Web Phone UI.

Configuring Display of DTMF Digits



Packet8 Web Phone UI

Use the following procedure to configure the display of DTMF digits on the IP phone.



Note: Display DTMF Digits is disabled by default.

1. Click on **Basic Settings->Preferences->General**.

Status System Information Operation User Password Phone Lock Softkeys and XML Directory Reset Basic Settings Preferences Call Forward	Preferences General Park Call: <input type="text"/> Pick Up Parked Call: <input type="text"/> Suppress DTMF Playback <input type="checkbox"/> Enabled Display DTMF Digits <input type="checkbox"/> Enabled Play Call Waiting Tone <input checked="" type="checkbox"/> Enabled Stuttered Dial Tone <input checked="" type="checkbox"/> Enabled XML Beep Support <input checked="" type="checkbox"/> Enabled Status Scroll Delay (seconds) <input type="text" value="5"/> Incoming Call Interrupts Dialing <input type="checkbox"/> Enabled Goodbye Key Cancels Incoming Call <input checked="" type="checkbox"/> Enabled
------------------------------------------------------------------------------------------------------------------------------------------------------------------------------------------	------------------------------------------------------------------------------------------------------------------------------------------------------------------------------------------------------------------------------------------------------------------------------------------------------------------------------------------------------------------------------------------------------------------------------------------------------------------------------------------------------------------------------------------------------------------------------------------------------------------------------------------------------------------------

2. Enable the **Display DTMF Digits** field by checking the check box. Disable this field by unchecking the box). Default is disabled.
3. Click to save your settings.

Enable/Disable Call Waiting

The call waiting feature notifies the user on an active call of a new incoming call. You can disable the call waiting feature, so that the new incoming call is automatically rejected by the phone with a busy message.

If you disable call waiting on the phone, and the user is on a call, any further incoming calls receive busy unless **Call Forward Busy** or **Call Forward No Answer and Busy** is configured on the phone (for information on "[Call Forwarding](#)", see [page 104](#).) It then forwards the call according to the rule configured. The phone can only:

- transfer the currently active call

or

- accept transferred calls if there are no active calls.

If call waiting is disabled:

- Intercom calls are treated as regular incoming calls and are rejected.
- pre-dialing with live dialpad disabled still accepts incoming calls.
- the **Incoming Call Interrupts Dialing** parameter is ignored because the incoming call is automatically rejected (for information on "[Incoming Call Interrupts Dialing](#)" see [page 146](#)).
- the Missed Calls List does not get updated with details of calls.
- the Blind Transfer feature on the phone may not work if two calls are made to the phone at one time.

You can disable call waiting using the configuration files or the Packet8 Web Phone UI.

Enabling/Disabling Call Waiting



Packet8 Web Phone UI

Use the following procedure to enable or disable Call Waiting on the IP phone.



Note: Call Waiting is enabled by default.

1. Click on **Basic Settings**->**Preferences**->**General**.

Status System Information Operation User Password Phone Lock Softkeys and XML Directory Reset Basic Settings Preferences Call Forward	<h3>Preferences</h3> <p>General</p> <p>Park Call: <input type="text"/></p> <p>Pick Up Parked Call: <input type="text"/></p> <p>Suppress DTMF Playback <input type="checkbox"/> Enabled</p> <p>Display DTMF Digits <input type="checkbox"/> Enabled</p> <p>Play Call Waiting Tone <input checked="" type="checkbox"/> Enabled</p> <p>Stuttered Dial Tone <input checked="" type="checkbox"/> Enabled</p> <p>XML Beep Support <input checked="" type="checkbox"/> Enabled</p> <p>Status Scroll Delay (seconds) <input type="text" value="5"/></p> <p>Incoming Call Interrupts Dialing <input type="checkbox"/> Enabled</p> <p>Goodbye Key Cancels Incoming Call <input checked="" type="checkbox"/> Enabled</p>
------------------------------------------------------------------------------------------------------------------------------------------------------------------------------------------	----------------------------------------------------------------------------------------------------------------------------------------------------------------------------------------------------------------------------------------------------------------------------------------------------------------------------------------------------------------------------------------------------------------------------------------------------------------------------------------------------------------------------------------------------------------------------------------------------------------------------------------------------------------------------------------------------------------------

2. Call Waiting is enabled by default. If required, disable the **Call Waiting** field by unchecking the check box.
3. Click  to save your settings.

Play Call Waiting Tone

You can enable or disable the playing of a call waiting tone when a caller is on an active call and a new call comes into the phone.

You can configure this feature using the Packet8 Web Phone UI.

Configuring Call Waiting Tone



Packet8 Web Phone UI

Use the following procedures to configure a call waiting tone on the IP phone.



Note: "Play Call Waiting Tone" is enabled by default.

1. Click on **Basic Settings->Preferences->General**.

Status System Information	Preferences
Operation User Password Phone Lock Softkeys and XML Directory Reset	General
Basic Settings Preferences Call Forward	Park Call: <input type="text"/>
	Pick Up Parked Call: <input type="text"/>
	Suppress DTMF Playback <input type="checkbox"/> Enabled
	Display DTMF Digits <input type="checkbox"/> Enabled
	Play Call Waiting Tone <input checked="" type="checkbox"/> Enabled
	Stuttered Dial Tone <input checked="" type="checkbox"/> Enabled
	XML Beep Support <input checked="" type="checkbox"/> Enabled
	Status Scroll Delay (seconds) <input type="text" value="5"/>
	Incoming Call Interrupts Dialing <input type="checkbox"/> Enabled
	Goodbye Key Cancels Incoming Call <input checked="" type="checkbox"/> Enabled

2. A call waiting tone is enabled by default. If required, disable the **Play Call Waiting Tone** field by unchecking the check box.
3. Click to save your settings.

Stuttered Dial Tone

You can enable or disable the playing of a stuttered dial tone when there is a message waiting on the IP phone.

You can configure this feature using the Packet8 Web Phone UI.

Configuring Stuttered Dial Tone



Packet8 Web Phone UI

Use the following procedures to configure stuttered dial tone on the IP phone.



Note: Stuttered Dial Tone is enabled by default.

1. Click on **Basic Settings->Preferences->General**.

Status System Information Operation User Password Phone Lock Softkeys and XML Directory Reset Basic Settings Preferences Call Forward	<h3>Preferences</h3> <p>General</p> <p>Park Call: <input type="text"/></p> <p>Pick Up Parked Call: <input type="text"/></p> <p>Suppress DTMF Playback <input type="checkbox"/> Enabled</p> <p>Display DTMF Digits <input type="checkbox"/> Enabled</p> <p>Play Call Waiting Tone <input checked="" type="checkbox"/> Enabled</p> <p>Stuttered Dial Tone <input checked="" type="checkbox"/> Enabled</p> <p>XML Beep Support <input checked="" type="checkbox"/> Enabled</p> <p>Status Scroll Delay (seconds) <input type="text" value="5"/></p> <p>Incoming Call Interrupts Dialing <input type="checkbox"/> Enabled</p> <p>Goodbye Key Cancels Incoming Call <input checked="" type="checkbox"/> Enabled</p>
------------------------------------------------------------------------------------------------------------------------------------------------------------------------------------------	----------------------------------------------------------------------------------------------------------------------------------------------------------------------------------------------------------------------------------------------------------------------------------------------------------------------------------------------------------------------------------------------------------------------------------------------------------------------------------------------------------------------------------------------------------------------------------------------------------------------------------------------------------------------------------------------------------------------

2. Stuttered dial tone is enabled by default. If required, disable the **Stuttered Dial Tone** field by unchecking the check box.
3. Click to save your settings.

Status Scroll Delay

Using the Packet8 Web Phone UI, you can specify a scroll delay option that allows you to set the time delay, in seconds, between the scrolling of each status message on the phone. You can specify this setting in the **Status Scroll Delay (seconds)** field at the path **Basic Settings->Preferences->General**. The default time is 5 seconds for each message to display before scrolling to the next message. You can increase or decrease this time as required. Setting and saving the value in the Packet8 Web Phone UI applies to the phone immediately.

Configuring Status Scroll Delay



Packet8 Web Phone UI

Use the following procedures to specify a status scroll delay on the IP phone.

1. Click on **Basic Settings->Preferences->General**.

Status	
System Information	
Operation	
User Password	
Phone Lock	
Softkeys and XML	
Directory	
Reset	
Basic Settings	
Preferences	
Call Forward	

Preferences	
General	
Park Call:	<input type="text"/>
Pick Up Parked Call:	<input type="text"/>
Suppress DTMF Playback	<input type="checkbox"/> Enabled
Display DTMF Digits	<input type="checkbox"/> Enabled
Play Call Waiting Tone	<input checked="" type="checkbox"/> Enabled
Stuttered Dial Tone	<input checked="" type="checkbox"/> Enabled
XML Beep Support	<input checked="" type="checkbox"/> Enabled
Status Scroll Delay (seconds)	<input type="text" value="5"/>
Incoming Call Interrupts Dialing	<input type="checkbox"/> Enabled
Goodbye Key Cancels Incoming Call	<input checked="" type="checkbox"/> Enabled

2. Enter a value in the **Status Scroll Delay (seconds)** field. Valid values are: 1 to 25 seconds. Default is 5 seconds.
3. Click to save your settings.

Incoming Call Interrupts Dialing

If you are dialing a call on your phone and another call comes in while you are dialing, you can allow the incoming call to interrupt dialing by enabling a parameter called **Incoming Call Interrupts Dialing**. You can enable or disable this parameter in the Packet8 Web Phone UI at the path **Basic Settings->Preferences->General**.

When you enable this field in the Packet8 Web Phone UI, an incoming call automatically interrupts the outgoing call during dialing and allows the phone to ring for you to answer the incoming call.

When you disable this parameter, which is the default, the phone does not interrupt the outgoing call during dialing and instead rings the incoming call on another free line (or sends busy signal if all remaining lines are busy). You have a choice to ignore the incoming call, or answer the incoming call on another line, via the **Ignore** and **Answer** softkeys that display. If you choose to answer the incoming call, you can answer the call, finish the call, and then hang up. You can still go back to the original outgoing call and finish dialing out.



Note: If you disable this field, and the phone receives an incoming call while you are dialing an outgoing call, you can pick up the call and perform transfer or conference as required.

Configuring Incoming Call Interrupts Dialing



Packet8 Web Phone UI

Use the following procedures to configure **Incoming Call Interrupts Dialing** on the IP Phone.



Note: Incoming Call Interrupts Dialing is disabled by default.

1. Click on **Basic Settings->Preferences->General**.

The screenshot shows the 'Preferences' page with the 'General' tab selected. The left sidebar contains a navigation menu with categories: Status (System Information), Operation (User Password, Phone Lock, Softkeys and XML, Directory, Reset), and Basic Settings (Preferences, Call Forward). The main content area lists various settings:

Preferences	
General	
Park Call:	<input type="text"/>
Pick Up Parked Call:	<input type="text"/>
Suppress DTMF Playback	<input type="checkbox"/> Enabled
Display DTMF Digits	<input type="checkbox"/> Enabled
Play Call Waiting Tone	<input checked="" type="checkbox"/> Enabled
Stuttered Dial Tone	<input checked="" type="checkbox"/> Enabled
XML Beep Support	<input checked="" type="checkbox"/> Enabled
Status Scroll Delay (seconds)	<input type="text" value="5"/>
Incoming Call Interrupts Dialing	<input type="checkbox"/> Enabled
Goodbye Key Cancels Incoming Call	<input checked="" type="checkbox"/> Enabled

2. Enable the **Incoming Call Interrupts Dialing** field by checking the check box. (Disable this field by unchecking the box). Default is disabled.
3. Click  to save your settings.

Goodbye Key Cancels Incoming Calls

The 6757i CT has a feature that allows you to configure the **Goodbye** key to drop a second incoming call or ignore incoming calls presented to the phone when you are on an active call. The parameter is called **Goodbye Key Cancels Incoming Call** and is configurable via the Packet8 Web Phone UI.

If you enable this parameter, which is the default, pressing the **Goodbye** key rejects calls coming into the phone while you are on an active call. When you disable this parameter, pressing the **Goodbye** key hangs up the active call.

If you disable this feature, and the phone receives another call when an active call is already present., the phone displays a softkey 1 as **Answer** and softkey 2 as **Ignore**.

Configuring Goodbye Key to Cancel Incoming Calls



Packet8 Web Phone UI

Use the following procedure to configure the **Goodbye** key to cancel incoming calls on the IP phone.



Note: Goodbye Key Cancels Incoming Call is enabled by default.

1. Click on **Basic Settings->Preferences->General**.

Status System Information Operation User Password Phone Lock Softkeys and XML Directory Reset Basic Settings Preferences Call Forward	<h3>Preferences</h3> <p>General</p> <p>Park Call: <input type="text"/></p> <p>Pick Up Parked Call: <input type="text"/></p> <p>Suppress DTMF Playback <input type="checkbox"/> Enabled</p> <p>Display DTMF Digits <input type="checkbox"/> Enabled</p> <p>Play Call Waiting Tone <input checked="" type="checkbox"/> Enabled</p> <p>Stuttered Dial Tone <input checked="" type="checkbox"/> Enabled</p> <p>XML Beep Support <input checked="" type="checkbox"/> Enabled</p> <p>Status Scroll Delay (seconds) <input type="text" value="5"/></p> <p>Incoming Call Interrupts Dialing <input type="checkbox"/> Enabled</p> <p>Goodbye Key Cancels Incoming Call <input checked="" type="checkbox"/> Enabled</p>
------------------------------------------------------------------------------------------------------------------------------------------------------------------------------------------	----------------------------------------------------------------------------------------------------------------------------------------------------------------------------------------------------------------------------------------------------------------------------------------------------------------------------------------------------------------------------------------------------------------------------------------------------------------------------------------------------------------------------------------------------------------------------------------------------------------------------------------------------------------------------------------------------------------------

2. The **Goodbye Key Cancels Incoming Call** field is enabled by default. If required, disable this field by unchecking the check box.
3. Click to save your settings.



IP Phone UI

IF	THEN
<p>Goodbye Key Cancels Incoming Call is enabled AND a second call comes in while you are on an active call,</p>	<p>press the Goodbye key to reject the second incoming call.</p>
<p>Goodbye Key Cancels Incoming Call is disabled AND a second call comes in while you are on an active call,</p>	<p>press the Goodbye key to hang up on the active call so you can answer the second incoming call.</p>
<p>Goodbye Key Cancels Incoming Call is disabled AND a second call comes in while you are on an active call,</p>	<p>press the Ignore softkey to ignore the second incoming call and remain on the active call OR press the Answer softkey to answer the second incoming call.</p>

Message Waiting Indicator

You can configure the Message Waiting Indicator (MWI) to illuminate for a specific line or for all lines. For example, if you configure the MWI LED on line 3 only, the LED illuminates if a voicemail is pending on line 3. If you configure the MWI LED for all lines, the LED illuminates if a voicemail is pending on any line on the phone (lines 1 through 9).

You configure the MWI indicator using the Packet8 Web Phone UI.

Configuring Message Waiting Indicator



Packet8 Web Phone UI

Use the following procedure to configure the message waiting indicator on a specific line or on all lines on the IP phone.



Note: Message Waiting Indicator Line parameter is set to **ALL** lines by default.

1. Click on **Basic Settings->Preferences->General**.

Status System Information Operation User Password Phone Lock Softkeys and XML Directory Reset Basic Settings Preferences Call Forward	<h3>Preferences</h3> <p>General</p> <p>Park Call: <input type="text"/></p> <p>Pick Up Parked Call: <input type="text"/></p> <p>Suppress DTMF Playback <input type="checkbox"/> Enabled</p> <p>Display DTMF Digits <input type="checkbox"/> Enabled</p> <p>Play Call Waiting Tone <input checked="" type="checkbox"/> Enabled</p> <p>Stuttered Dial Tone <input checked="" type="checkbox"/> Enabled</p> <p>XML Beep Support <input checked="" type="checkbox"/> Enabled</p> <p>Status Scroll Delay (seconds) <input type="text" value="5"/></p> <p>Incoming Call Interrupts Dialing <input type="checkbox"/> Enabled</p> <p>Goodbye Key Cancels Incoming Call <input checked="" type="checkbox"/> Enabled</p>
------------------------------------------------------------------------------------------------------------------------------------------------------------------------------------------	----------------------------------------------------------------------------------------------------------------------------------------------------------------------------------------------------------------------------------------------------------------------------------------------------------------------------------------------------------------------------------------------------------------------------------------------------------------------------------------------------------------------------------------------------------------------------------------------------------------------------------------------------------------------------------------------------------------------

2. The **Message Waiting Indicator Line** field is set to **ALL** lines by default. If required, change the setting to a specific line by selecting a line from the list. **Valid values are All and lines 1 through 9.**
3. Click to save your settings.

Incoming Intercom Call Features

Incoming Intercom

By default, the IP phone allows incoming Intercom calls to be automatically answered without having to set up an Intercom key on your phone. The phone automatically plays a warning tone when it receives an incoming Intercom call. It also mutes the microphone. If the Intercom call comes into the phone while an active call is already present, the phone puts the active call on hold and answers the Intercom call.

You can change the behavior of how the phone handles incoming Intercom calls by enabling/disabling specific parameters using the Packet8 Web Phone UI. The following table describes these features.

Incoming Intercom Features in Packet8 Web Phone UI	Description
Microphone Mute	Allows you to enable or disable the microphone on the IP phone for Intercom calls made by the originating caller.
Auto Answer	Allows you to enable or disable the IP phone to automatically answer an Intercom call. If auto-answer is enabled on the IP phone, the phone plays a tone (if Play Warning Tone is enabled) to alert the user before answering the Intercom call. If auto-answer is disabled, the phone rejects the incoming Intercom call and sends a busy signal to the caller. Note: Your Administrator can set a time period delay before the phone automatically answers. Contact your System Administrator for more information.
Play Warning Tone	Allows you to enable or disable a warning tone to play when the phone receives an incoming Intercom call on an active line.
Allow Barge In	Allows you to enable or disable how the phone handles incoming Intercom calls while the phone is on an active call.

Microphone Mute

You can mute or unmute the microphone on the IP phone for Intercom calls made by the originating caller. If you want to mute the Intercom call, you enable this feature. If you want to unmute (or hear the Intercom call), you disable this feature. **Microphone Mute** is enabled by default.

Auto-Answer/Play Warning Tone

The auto-answer feature on the IP phone allows you to enable or disable automatic answering for an Intercom call. If **Auto-Answer** is enabled, the phone automatically answers an incoming Intercom call. If **Play Warning Tone** is also enabled, the phone plays a tone to alert you before answering the Intercom call. If **Auto-Answer** is disabled, the phone rejects the incoming Intercom call and sends a busy signal to the caller.

Auto-Answer and **Play Warning Tone** are enabled by default.



Note: Your Administrator can set a time period delay before the phone automatically answers. Contact your System Administrator for more information.

Allow Barge In

You can configure whether or not the IP phone allows an incoming Intercom call to interrupt an active call. The **Allow Barge In** parameter controls this feature. When you enable this parameter, which is the default value, an incoming Intercom call takes precedence over any active call, by placing the active call on hold and automatically answering the Intercom call. When you disable this parameter, and there is an active call, the phone treats an incoming Intercom call like a normal call and plays the call warning tone. **Allow Barge In** is disabled by default.

Configuring Incoming Intercom Settings



Packet8 Web Phone UI

Use the following procedure to configure incoming Intercom call settings on the IP phone.

1. Click on **Basic Settings->Preferences->Incoming Intercom Settings**.

<ul style="list-style-type: none"> Status System Information Operation User Password Phone Lock Softkeys and XML Directory Reset Basic Settings Preferences Call Forward 	<h3>Preferences</h3> <h4>Incoming Intercom Settings</h4> <ul style="list-style-type: none"> Auto-Answer <input type="checkbox"/> Enabled Microphone Mute <input checked="" type="checkbox"/> Enabled Play Warning Tone <input checked="" type="checkbox"/> Enabled Allow Barge In <input checked="" type="checkbox"/> Enabled
---------------------------------------------------------------------------------------------------------------------------------------------------------------------------------------------------------------------------------------------------------------------------------------------------	-------------------------------------------------------------------------------------------------------------------------------------------------------------------------------------------------------------------------------------------------------------------------------------------------------------------------------------------------------------------------

- The **Auto-Answer** field is enabled by default. The automatic answering feature is turned on for the IP phone for answering Intercom calls. To disable this field, uncheck the box.

 **Note:** If the Auto-Answer field is not checked (disabled), the phone rejects the incoming Intercom call and sends a busy signal to the caller.

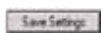
- The **Microphone Mute** field is enabled by default. The microphone is muted on the IP phone for Intercom calls made by the originating caller. To disable this field, uncheck the box.
- The **Play Warning Tone** field is enabled by default. If **Auto-Answer** is enabled, the phone plays a warning tone when it receives in incoming Intercom call. To disable this field, uncheck the box.
- The **Allow Barge In** field is disabled by default. If **Allow Barge In** is enabled, the phone puts an active call on hold and answers the incoming Intercom call. To enable the field, check the box.
- Click  to save your settings.

Model 536EM and 560EM Expansion Modules

The 6757i CT IP Phone offers optional 536EM and 560EM Expansion Modules that attach to the right side of the phone to provide additional softkeys.

Model 536EM

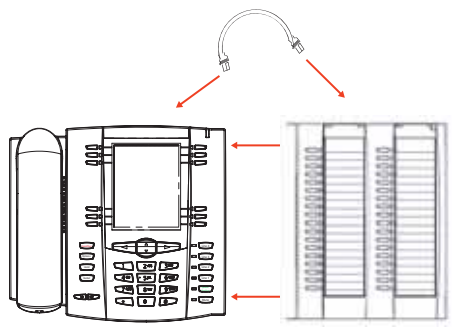

The 536EM provides 18 softkeys in each column (totaling 36 keys) on the keypad. Each key provides an LED for indicating call status. The 536EM provides a paper label for convenient key labeling.

Model 560EM

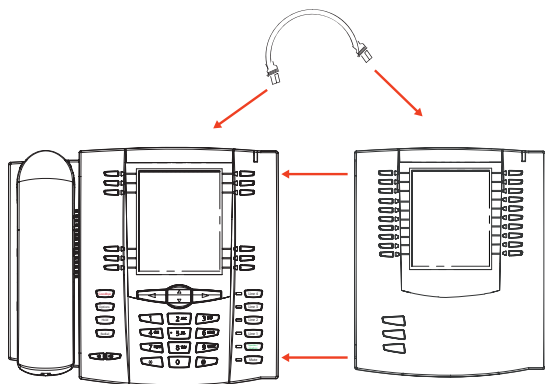

The 560EM provides 10 softkeys in each column (totaling 20 keys) on the keypad. The 560M also provides 3 keys at the bottom left of the unit. These keys represent **Page 1**, **Page 2**, and **Page 3** of the LCD display. The 560EM has 20 keys available on each page (totaling 60 softkeys). Each key provides an LED for indicating call status. The 560EM provides an LCD for displaying key labels.

The softkeys support the following features:

- Busy Lamp Fields (BLFs) (maximum of 50)
- Speeddial
- Shared Call Appearance
- Phone Lock

You can configure the softkeys using the Packet8 Web Phone UI.

Reference

For more information about configuring the expansion module softkeys with these functions, see the "[Softkeys](#)" on [page 48](#).

Using the Expansion Modules

536EM Expansion Module

After configuring the softkeys on the 536EM Expansion Module, you can record the name of the softkey on the paper labels provided with the Expansion Module. Press the softkey you want to use when applicable.

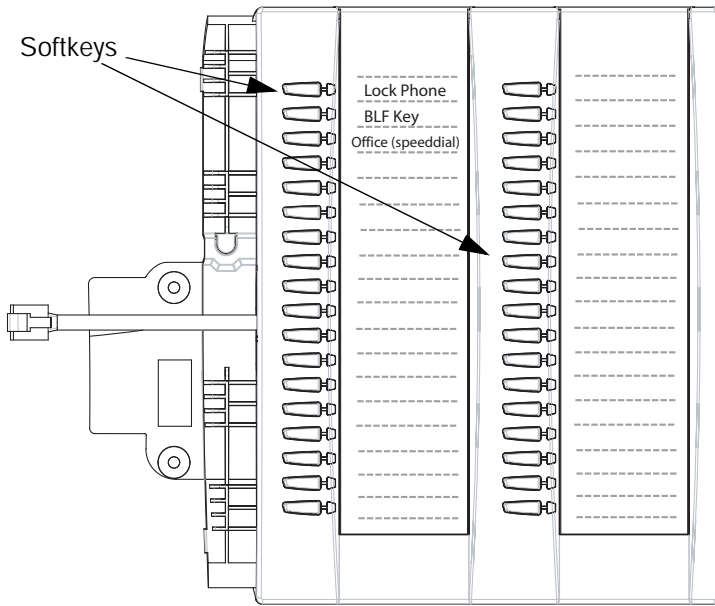

560EM Expansion Module

The 560EM Expansion Module screen displays softkeys in column format. The function keys on the bottom left of the Module allow you to display 3 full screens of softkeys. Each screen consists of 2 columns with the following default headings on each page:

- Page 1 List 1 and List 2
- Page 2 List 3 and List 4
- Page 3 List 5 and List 6.

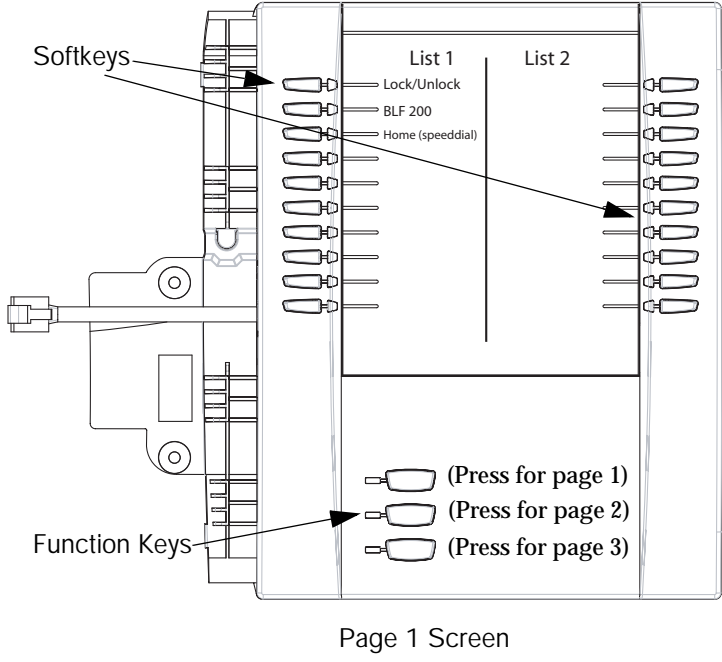

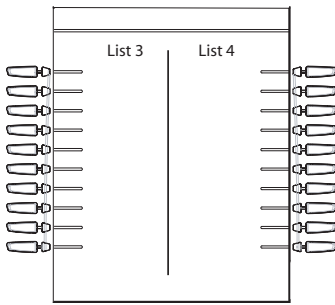

Page 2 Screen

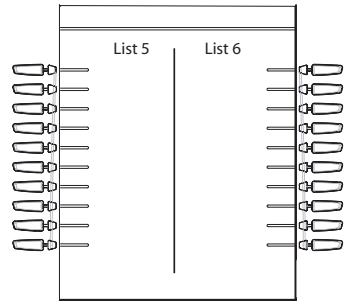

Page 3 Screen

To use the 560EM, press the function key for the page you want to display to the LCD (page 1, page2, or page 3), and press the applicable softkey.



Note: Your System Administrator can customize the headings on each 560EM Expansion Module screen. Contact your System Administrator for more information.

References

For more information about configuring softkeys, see "[Softkeys](#)" on [page 48](#).



You can purchase the 536EM and 560EM modules by going to www.Packet8.net.

Troubleshooting Solutions

Why is my display blank?

Ensure that power is being provided to your phone. If your network does not provide inline power over Ethernet, you can obtain an additional accessory, the Packet8 PoE (Power over Ethernet) inline power supply, to provide power over Ethernet locally to your phone. See the section **Connecting to the Network and to Power** in the *Packet8 6755i User Reference Manual* for details.

Why is my speakerphone not working?

If you press the  button and the speaker light flashes and you do not hear dial tone through the speaker phone, the Set Audio option in the phone's Options list has been set up for headset use. Press  a second time and if the light goes out, the phone has been set up to be used only with a headset or handset. If the light stays on steady and you hear dial tone, the phone has been set up so that you can alternate between the speakerphone and the headset by pressing . See the section "Customizing Your Phone" on page 25 for instructions on how to change the Set Audio option.

Why can't I get a dial tone?

Check for any loose connections and that the phone has been installed properly. For installation instructions, please refer to the **Installation and Setup** section in the *Packet8 6755i User Reference Manual* provided with your phone.

Why doesn't my phone ring?

Check the ring volume on your phone. It may be turned down or turned off. To adjust the ringer volume setting, press the volume button when the phone is on-hook and idle. For more information, refer to the **Adjusting Volume** section in the *Packet8 6755i User Reference Manual* provided with your phone.

Why is my handset not working?

Check to ensure that the handset cord is fully connected to both the phone and handset. See the section **Connecting a Handset or Headset** in the *Packet8 Packet8 6755i User Reference Manual* for information.

What are services, and how do I use them?

Services on the IP phone include:

- Callers List
- Phonebook
- Voicemail

See the section, "[Setting Services Key](#)" on [page 64](#) more information about the options available under "Services".

How do I find the IP address of my phone?

Instructions on where to find the IP address of your phone can be found in this guide in the section, "[Finding Your Phone's IP Address](#)" on [page 23](#).

Why does my phone display the No Service message?





The phone displays the **No Service** message if the SIP settings have not been set up correctly. Contact your System Administrator for more information.

How do I change my user password?

You can change the user password from the IP phone UI or the Packet8 Web Phone UI.



IP Phone UI

1. Press  on the phone to enter the Options List.
2. Select **User Password** and press .
3. Enter the current user password and press .
4. Enter the new user password and press .
5. Re-enter the new user password and press . A message, "*Password Changed*" displays on the screen.



Packet8 Web Phone UI

1. Click on **Operation->User Password**.

Status System Information	Reset User Password Please enter the current and new passwords Current Password <input type="text"/> New Password <input type="text"/> Password Confirm <input type="text"/> <input type="button" value="Save Settings"/>
Operation User Password Phone Lock Softkeys and XML Programmable Keys Directory Reset	
Basic Settings Preferences Call Forward	

2. In the **Current Password** field, enter the current user password.



Note: By default, the user name is "user" (all lowercase) and the password field is left blank. If you have forgotten your password, contact your System Administrator for assistance.

3. In the **New Password** field, enter the new user password.
4. In the **Password Confirm** field, enter the new user password again.
5. Click  to save your changes.







For information about changing your password, see "[User Password](#)" on [page 40](#).

Why does my phone display Bad Encrypted Config?

The IP phone displays **Bad Encrypted Config** because encrypted configuration files are enabled but the decryption process has failed. Report this error to your System Administrator.

How do I restart the IP phone?

IP Phone UI

1. Press the  button on the phone to enter the Option List.
2. Use the  key to scroll down the list of options to **Phone Status** and press the  key to select.
3. Press the  key to scroll to the **Restart Phone** option.
4. Press the  key to confirm and restart the phone. If you do not wish to restart your phone, press the  key to cancel.



Note: Your phone is out of service temporarily during the restart and downloading process.

Packet8 Web Phone UI

1. Click on **Operation->Reset**.

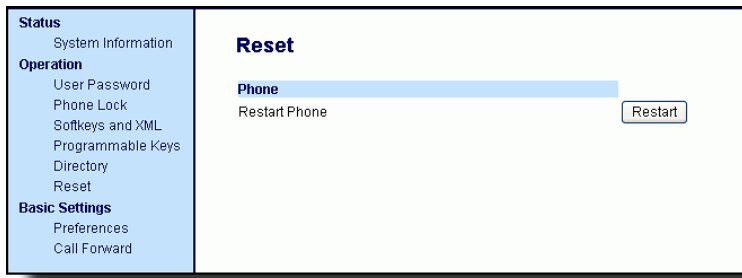

2. Click .
3. Click **OK** at the confirmation prompt.

How do I lock my phone?

You can lock your phone to prevent the phone from being used or configured using any of the following:





- At the path **Options**->**Phone Lock** on the IP Phone UI.
- At the path **Operations**->**Phone Lock** on the Packet8 Web Phone UI.
- At a configured key on the phone. For more information about configuring a Lock/Unlock key on your phone, see "[Phone Lock Key](#)" on [page 73](#).

Use the following procedures to lock an IP phone and prevent it from being used or configured.





IP Phone UI

Lock the Phone

1. Press  on the phone to enter the Options List.
2. Select **Phone Lock** and press .
3. Press  to set the phone to lock.
4. Press  on the phone. The following message displays:
Phone is locked.

Unlock the Phone

1. Press  on the phone to enter the Options List.
2. Enter your user password and press . The phone unlocks.



Packet8 Web Phone UI

1. Click on **Operation**->**Phone Lock**.

Status System Information	Phone Lock
Operation User Password Phone Lock Softkeys and XML Programmable Keys Directory Reset	Lock or unlock the phone Emergency Dial Plan <input type="text" value="9911/9999/9112/9110"/> Lock the phone? <input type="button" value="Lock"/> Reset User Password <input type="button" value="Reset"/> <input type="button" value="Save Settings"/>
Basic Settings Preferences Call Forward	

Lock the Phone

2. In the **Lock the Phone?** field, click . The phone locks dynamically and displays the following message: **Phone is locked.**

Unlock the Phone

3. Click on **Operation->Phone Lock.**
4. In the "**Unlock the Phone?**" field, click . The phone unlocks dynamically and displays the following message: **Phone is unlocked.**

Appendix A - Time Zone Codes

The following table identifies the time zone name and time zone code to use on the IP phone.

Time Zone Name/Time Zone Code Table

Time Zone Name	Time Zone Code
AD-Andorra	CET
AG-Antigua	AST
AI-Anguilla	AST
AL-Tirane	CET
AN-Curacao	AST
AR-Buenos Aires	ART
AS-Pago Pago	BST
AT-Vienna	CET
AU-Lord Howe	LHS
AU-Tasmania	EST
AU-Melbourne	EST
AU-Sydney	EST
AU-Broken Hill	CST
AU-Brisbane	EST
AU-Lindeman	EST
AU-Adelaide	CST
AU-Darwin	CST
AU-Perth	WST
AW-Aruba	AST
BA-Sarajevo	EET
BB-Barbados	AST
BE-Brussels	CET
BG-Sofia	EET
BM-Bermuda	AST
BO-La Paz	BOT
BR-Noronha	FNT
BR-Belem	BRT
BR-Fortaleza	BRT
BR-Recife	BRT
BR-Araguaina	BRS
BR-Maceio	BRT
BR-Sao Paulo	BRS
BR-Cuiaba	AMS
BR-Porto Velho	AMT
BR-Boa Vista	AMT
BR-Manaus	AMT
BR-Eirunepe	ACT
BR-Rio Branco	ACT
BS-Nassau	EST
BY-Minsk	EET
BZ-Belize	CST

Appendix A - Time Zone Codes

Time Zone Name	Time Zone Code
CA-Newfoundland	NST
CA-Atlantic	AST
CA-Eastern	EST
CA-Saskatchewan	EST
CA-Central	CST
CA-Mountain	MST
CA-Pacific	PST
CA-Yukon	PST
CH-Zurich	CET
CK-Rarotonga	CKS
CL-Santiago	CLS
CL-Easter	EAS
CN-China	CST
CO-Bogota	COS
CR-Costa Rica	CST
CU-Havana	CST
CY-Nicosia	EES
CZ-Prague	CET
DE-Berlin	CET
DK-Copenhagen	CET
DM-Dominica	AST
DO-Santo Domingo	AST
EE-Tallinn	EET
ES-Madrid	CET
ES-Canary	WET
FI-Helsinki	EET
FJ-Fiji	NZT
FK-Stanley	FKS
FO-Faeroe	WET
FR-Paris	CET
GB-London	GMT
GB-Belfast	GMT
GD-Grenada	AST
GF-Cayenne	GFT
GI-Gibraltar	CET
GP-Guadeloupe	AST
GR-Athens	EET
GS-South Georgia	GST
GT-Guatemala	CST
GU-Guam	CST
GY-Guyana	GYT
HK-Hong Kong	HKS
HN-Tegucigalpa	CST
HR-Zagreb	CET
HT-Port-au-Prince	EST
HU-Budapest	CET
IE-Dublin	GMT
IS-Reykjavik	GMT
IT-Rome	CET

Time Zone Name	Time Zone Code
JM-Jamaica	EST
JP-Tokyo	JST
KY-Cayman	EST
LC-St Lucia	AST
LI-Vaduz	CET
LT-Vilnius	EET
LU-Luxembourg	CET
LV-Riga	EET
MC-Monaco	CET
MD-Chisinau	EET
MK-Skopje	CET
MQ-Martinique	AST
MS-Montserrat	AST
MT-Malta	CET
MX-Mexico City	CST
MX-Cancun	CST
MX-Merida	CST
MX-Monterrey	CST
MX-Mazatlan	MST
MX-Chihuahua	MST
MX-Hermosillo	MST
MX-Tijuana	PST
NI-Managua	CST
NL-Amsterdam	CET
NO-Oslo	CET
NR-Nauru	NRT
NU-Niue	NUT
NZ-Auckland	NZS
NZ-Chatham	CHA
PA-Panama	EST
PE-Lima	PES
PL-Warsaw	CET
PR-Puerto Rico	AST
PT-Lisbon	WET
PT-Madeira	WET
PT-Azores	AZO
PY-Asuncion	PYS

Appendix A - Time Zone Codes

Time Zone Name	Time Zone Code
RO-Bucharest	EET
RU-Kaliningrad	EET
RU-Moscow	MSK
RU-Samara	SAM
RU-Yekaterinburg	YEK
RU-Omsk	OMS
RU-Novosibirsk	NOV
RU-Krasnoyarsk	KRA
RU-Irkutsk	IRK
RU-Yakutsk	YAK
RU-Vladivostok	VLA
RU-Sakhalin	SAK
RU-Magadan	MAG
RU-Kamchatka	PET
RU-Anadyr	ANA
SE-Stockholm	CET
SG-Singapore	SGT
SI-Ljubljana	CET
SK-Bratislava	CET
SM-San Marino	CET
SR-Paramaribo	SRT
SV-El Salvador	CST
TR-Istanbul	EET
TT-Port of Spain	AST
TW-Taipei	CST
UA-Kiev	EET
US-Eastern	EST
US-Central	CST
US-Mountain	MST
US-Pacific	PST
US-Alaska	AKS
US-Aleutian	HAS
US-Hawaii	HST
UY-Montevideo	UYS
VA-Vatican	CET
YU-Belgrade	CET

Limited Warranty

This warranty applies only to products purchased and used in the United States.

What Is Covered?

Any defect in materials or workmanship for one year. (See Packet8 Virtual Office terms and conditions.)

Support

Web/FAQs: www.packet8.net/support/faqs

Email: virtualoffice@packet8.net

Phone: 888-898-8733 and press option [1] for Virtual Office, then option [2] for support.

Outside the U.S.: 408-687-4120

Warning!

Toll fraud is committed when individuals unlawfully gain access to a customer's telecommunication system. This is a criminal offense. Currently, we do not know of any telecommunications system that is immune to this type of criminal activity. 8x8, Inc. will not accept liability for any damages, including long distance charges, which result from unauthorized and/or unlawful use. Although 8x8, Inc. has designed security features into its products and services, it is your sole responsibility to use the security features and to establish security practices within your organization, including training, security awareness, and call auditing to eliminate security risks.

Notice

While every effort has been made to ensure accuracy, 8x8, Inc. will not be liable for technical or editorial errors or omissions contained within this documentation. The information contained in this documentation is subject to change without notice.

This documentation may be used only in accordance with the terms of the 8x8, Inc. License Agreement.

If you've read this owner's manual and consulted the online Troubleshooting section at www.Packet8.net and still have problems, please call 1-888-898-8733 for technical assistance.