

# NAUTICAST- INLAND AIS

## AUTOMATIC IDENTIFICATION SYSTEM - INLAND

### Installation Manual

P/N 2662

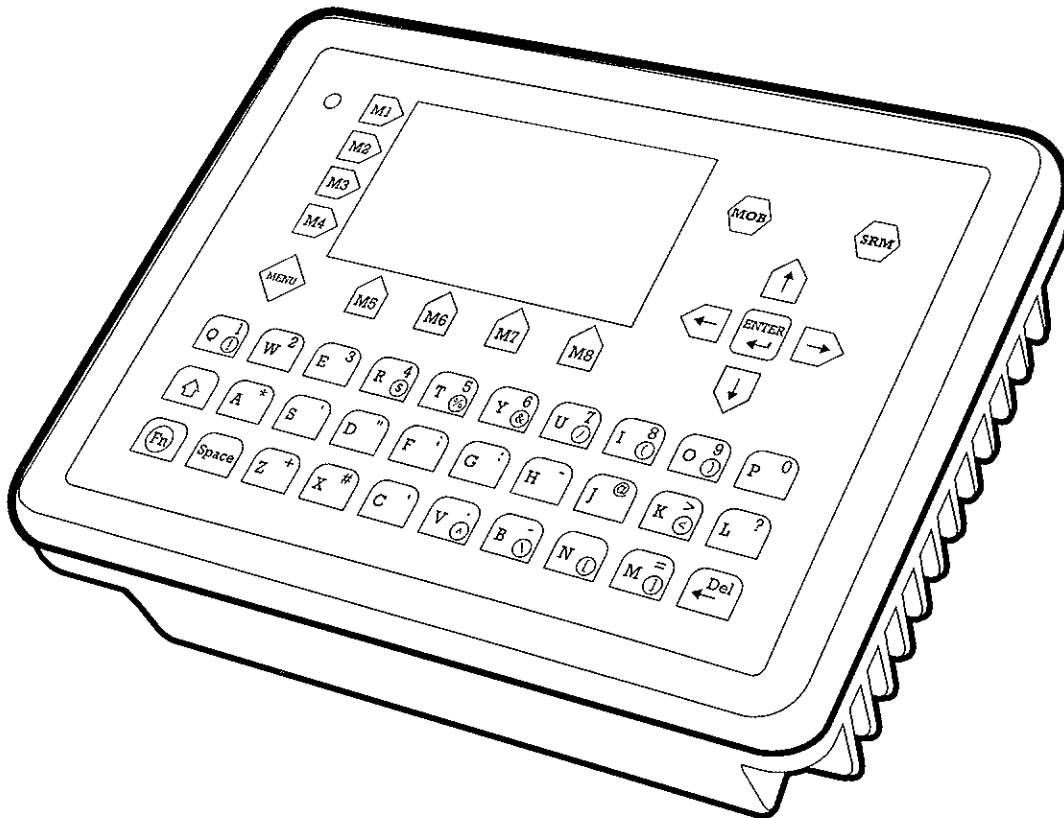

ACR Electronics, Inc.  
5757 Ravenswood Road  
Fort Lauderdale, FL 33312  
+1(954) 981-3333  
Fax +1 (954) 983-5087  
[www.acrelectronics.com](http://www.acrelectronics.com)  
Email: [Info@acrelectronics.com](mailto:Info@acrelectronics.com)

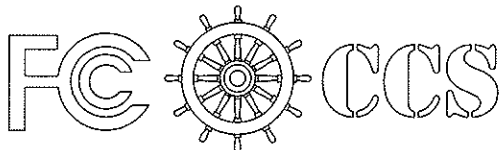

## **Please read this first!**

### Warning:

Although ACR strives for accuracy in all its publications; this material may contain errors or omissions, and is subject to change without prior notice. ACR shall not be made liable for any specific, indirect, incidental or consequential damages as a result of its use. ACR components may only be used in safety of life devices or systems, with the express written approval of ACR, as the failure of such components could cause the failure of the ACR device or system. If these fail, it is reasonable to assume that the safety of the user or other persons may be endangered.

Copying of this document, and giving it to others and the use or communication of the contents thereof, are forbidden without express authority. Offenders are liable to the payment of damages.

**Weitergabe sowie Vervielfältigung dieser Unterlage, Verwertung und Mitteilung ihres Inhaltes nicht gestattet, soweit nicht ausdrücklich zugestanden. Zuwiderhandlungen verpflichten zu Schadenersatz.**

Toute communication ou reproduction de ce document, toute exploitation ou communication de son contenu sont interdites, sauf autorisation expresse. Tout manquement à cette règle est illicite et expose son auteur au versement de dommages et intérêts.

Sin nuestra expresa autorización, queda terminantemente prohibida la reproducción total o parcial de este documento, así como su uso indebido y/o su exhibición o comunicación a terceros. De los infractores se exigirá el correspondiente resarcimiento de daños y perjuicios.

1	GENERAL INTRODUCTION .....	1
1.1	Description of AIS .....	1
1.2	AIS in an Operational Environment .....	2
1.3	AIS Networks .....	3
2	NAUTICAST .....	4
2.1	System Overview .....	4
3	INSTALLATION .....	5
3.1	Installation Requirements .....	5
3.2	Installation Overview .....	5
3.3	General Interface Description .....	7
3.4	Interface NMEA Description: .....	8
3.4.1	Sensor - Interface CH1, CH2, CH3 .....	8
3.4.2	ECDIS – Presentation Interface CH 4 .....	8
3.4.3	Pilot Port CH 5 .....	9
3.4.4	Long Range CH 8 .....	9
3.4.5	DGPS – DGNSS Channel 9 .....	10
3.4.6	Alarm Circuit – BIIT Channel 10 .....	10
3.4.7	Proprietary Sentences .....	10
3.5	Sensor Interface Definitions .....	11
3.5.1	Talker drive circuits .....	11
3.5.2	Listener Receiver Circuits .....	11
3.5.3	Electrical isolation .....	11
3.5.4	Maximum voltage on the bus .....	11
3.5.5	Data transmission .....	11
3.6	Sensor notes .....	12
3.7	Sensor Hardware Installation .....	13
3.7.1	Installation of an RS422 serial interface: .....	13
3.8	Sensor Software Configuration .....	14
3.8.1	Introduction .....	14
3.8.2	Set up Sensor Speed, Checksum (CRC) and NMEA Talker and Sentence ID .....	14
3.8.3	Real-Time Analysis of NMEA Data Streams .....	17
3.8.4	Sensor Monitoring for Problem Analysis .....	19
3.8.5	Priority Handling of Sensor Sentence .....	20
3.8.6	Supported NMEA-0183 Sentences .....	20
3.8.7	Calculated Values .....	24
3.8.8	Versions of NMEA Sentences .....	24
3.9	Pin-Description AIS-Cable / Socket 50-Pins: .....	25
3.10	Pin-Description AIS-Connector: .....	26
3.11	Pin-Description Communication-Cable / Socket 50-Pins .....	27
3.12	Communication Cable RS232 (Sub-D 50 Socket) .....	28
3.13	Installation of VHF / GPS Antennas .....	29
3.13.1	VHF Antenna Installation .....	29
3.13.2	GNSS Antenna installation .....	30
3.14	Power Supply .....	31
4	STARTING THE NAUTICAST .....	32
4.1	Initial Set Up of the NAUTICAST for operation .....	32
4.2	Entering the MMSI / IMO / DAC / ESN Numbers .....	33
4.3	Entering Ship Settings .....	36
4.4	Entering Voyage Related Data .....	38
4.5	Service and User Passwords .....	41
5	TROUBLESHOOTING .....	44
5.1	Reading and understanding Alarms: .....	44
5.2	Alarm Codes .....	45
5.3	Text Messages .....	46
5.4	Restarting the NAUTICAST .....	46
6	ACCESSORIES .....	47
7	TECHNICAL INFORMATION .....	48
8	CONTACT AND SUPPORT INFORMATION .....	49
9	APPENDIX .....	50
9.1	Samples for battery calculation .....	50
9.1.1	Typical Installation .....	50
9.1.2	RM GMDSS Compact-Console Area A3 with 250 W MF/HF .....	51
9.1.3	RM GMDSS Compact-Console Area A3 with 400 W MF/HF .....	51
9.2	Drawings and Approvals .....	52

## History of Changes

Date	Version	Rev.	Status	Comments	Responsible
2005-11-01	1.0.0	A	Released		A. Lesch
2006-07-14	1.0.1	B	Released	Editorial work	M. D'Arcangelo
2006-10-11	1.0.2	C	Released	Character Change-out Edits	M.D'Arcangelo

# 1 General Introduction

## 1.1 Description of AIS

### What does the abbreviation AIS stand for?

AIS stands for: "Automatic Identification System"

### What is AIS?

According to IALA regulations, AIS is defined as follows:

Very simply, the AIS is a broadcast Transponder system, operating in the VHF maritime mobile Band. It is capable of sending ship information such as identification, position course, speed and more, to other ships and to shore. It can handle multiple reports at rapid update rates and uses Self-Organizing Time Division Multiple Access (SOTDMA) technology to meet these high broadcast rates and ensure reliable and robust ship to ship operation.

### What are the performance standards of AIS?

The IMO defines the performance standards as follows:

- Ship to Ship working
- Ship to Shore working, including Long Range Application
- Automatic and continuous operation
- Provision of information messaging
- Utilization of maritime VHF channels

### Which modules make up an AIS-Transponder?

The Modules:

- DGPS / GPS receiver
- VHF Radio
- Antenna
- Computer (CPU)
- Power Supply

Appropriate application software connects the individual modules.

### In which modes does AIS function?

AIS are required to function flawlessly in a variety of modes. The relevant regulations require:

The system shall be capable of

- An "**autonomous and continuous**" mode for operation in all areas. This mode shall be capable of being switched to/from one of the following alternate modes by a competent authority;
- An "**assigned**" mode for operation in an area subject to a competent authority responsible for traffic monitoring such that the data transmission interval and/or time slots may be set remotely by that authority;
- A "**polling or controlled**" mode, where the data transfer occurs in response to interrogation from a ship or competent authority.

## 1.2 AIS in an Operational Environment

This illustration depicts a typical AIS System, where two or more AIS equipped vessels (and shore based systems) are automatically communicating with each other.

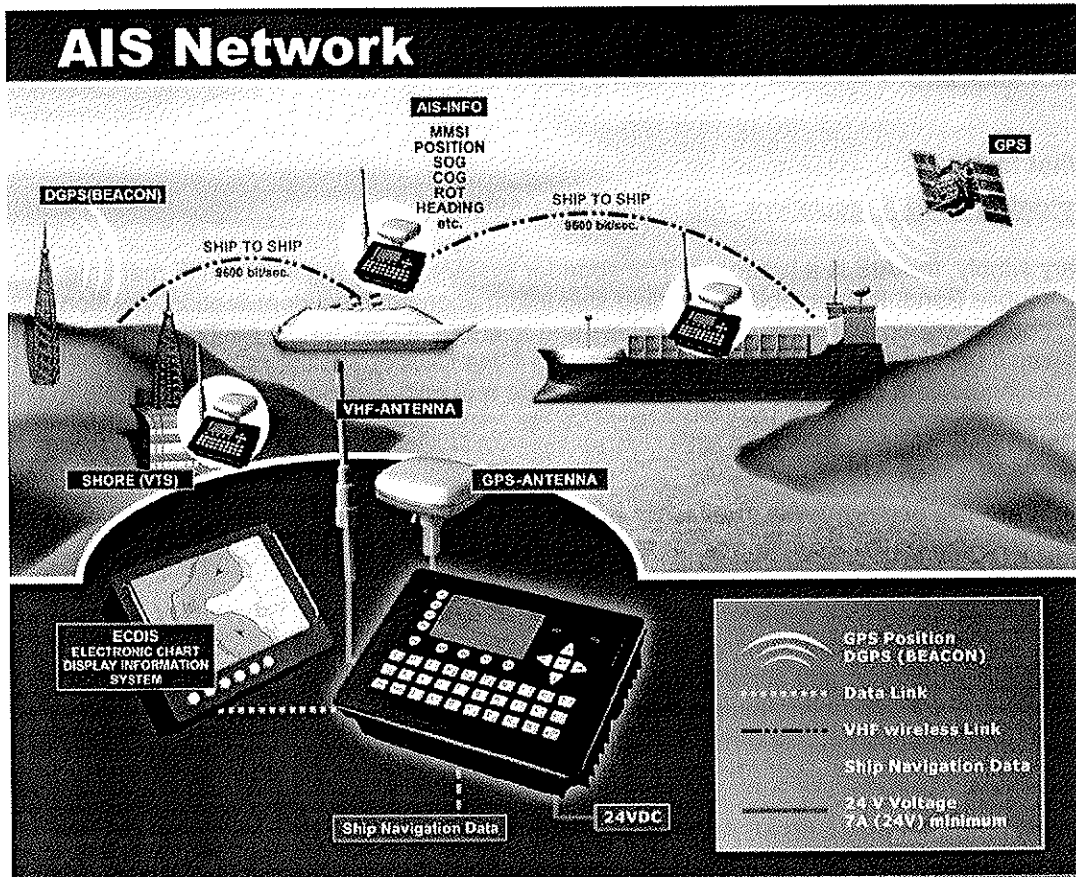

On the bottom, a typical NAUTICAST installation in a common environment is shown. The NAUTICAST is connected to the vessels emergency power supply, and in connection with the VHF, and GPS-Antennas, the minimal requirements for Transponder operation are fulfilled.

Both vessels in the above illustration are equipped with a NAUTICAST (or any other certified AIS-Transponder). Due to "Time – Synchronization" they use the same organization of free and allocated windows (Slots) in the shared VHF Data Link (this method is called "Self Organized Time Division Multiple Access") to send and receive messages.

Without the necessity of any active interaction, both vessels know exactly who or what is cruising nearby and where the individual object is heading.

### 1.3 AIS Networks

The scenario below shows a full AIS coverage area (including all applications and complete shore infrastructure).

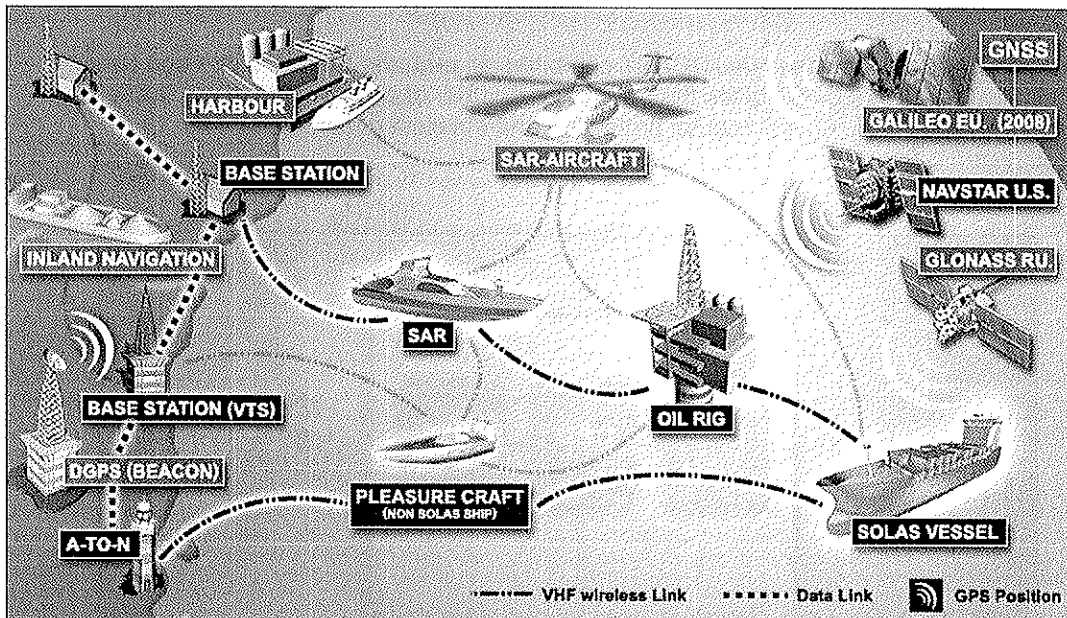

The Carriage Requirement currently applies to SOLAS Vessels and will be extended on Inland Waterways.

## 2 NAUTICAST

### 2.1 System Overview

Unlike other AIS devices, the NAUTICAST combines all required functions into one cabinet. Additionally, the NAUTICAST gives the operator a number of additional features (easy mounting & installation, environmental protection and smallest dimensions).

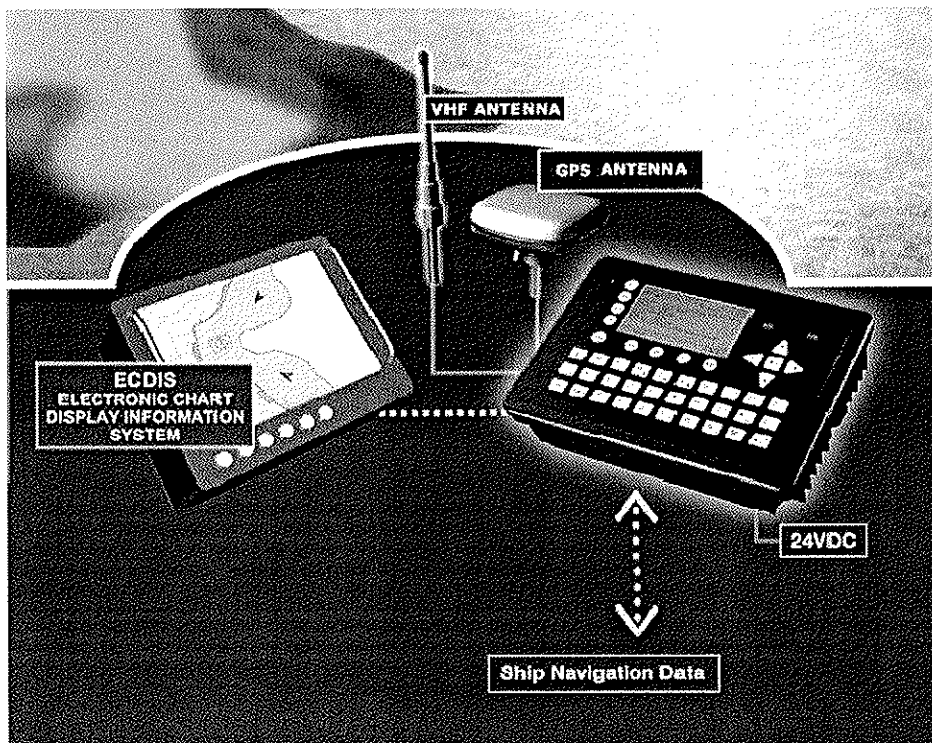
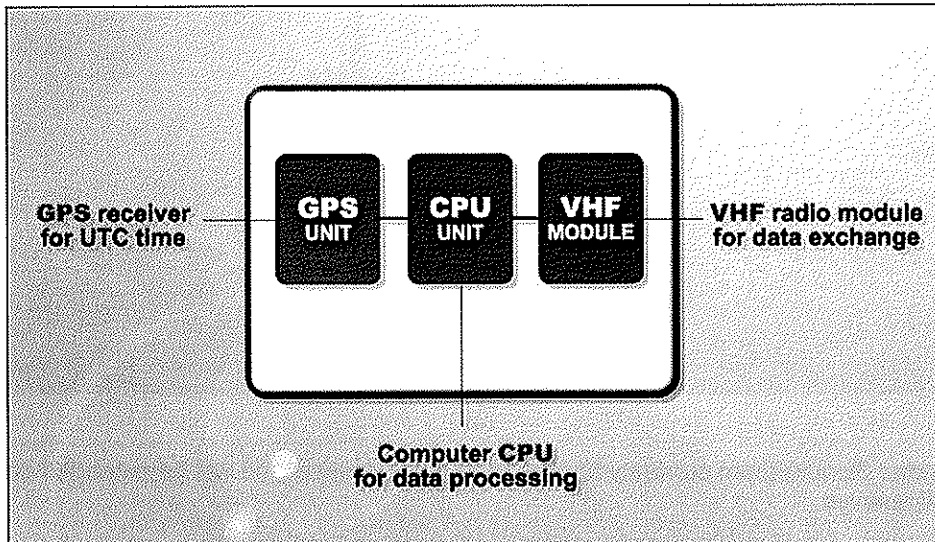



### **3 Installation**

**IMPORTANT: AUTHORITIES MANDATES** that after the physical installation has been successfully completed, all ships data and settings be entered into the AIS transponder. See Section 4 for further instructions.

#### **3.1 Installation Requirements**

##### **General Requirements**

Please note that international conventions, regulations, instructions and guidelines have to be adhered to when installing the NAUTICAST.

The following points must be observed before installation can commence:

- Permission by the local authority to install such a device must be granted.
- Trained service personnel must undertake the installation.
- The NAUTICAST must be fitted in a suitable place on the bridge.
- The VHF and GPS Antennas must be installed in a suitable position, where excellent reception conditions apply (refer to Chapter 3.10 Installation of VHF antenna)
- All available interfaces must be installed.
- The vessels power supply must suffice, and the GMDSS power supply has to be used.
- Installation of the pilot plug in conning position (close to the pilot working place).

#### **3.2 Installation Overview**

##### **Survey**

AIS is considered part of the ship's radio station and is surveyed together with radio installation. Surveys on SOLAS Convention ships should be carried out in accordance with the rules laid down in IMO Res. A 746(18) "Survey Guidelines under the harmonized system of survey and certification" (R) 8, and "Protocol of 1988 relating to the International Convention for the Safety of Life at Sea, 1974."

The NAUTICAST consists of one unit, which integrates all necessary modules.

## Step-by-Step Installation Procedure:

- Mount the NAUTICAST close to ships operation workstation for traffic surveillance and maneuvering.
- Use the VHF adapter cable (P/N 2612) together with the VHF plug and TNC plug to connect the VHF and GPS antenna cables and antennas.
- The sensors, ECDIS, PC, pilot case, long range devices and auxiliary displays can be connected to the NAUTICAST cabinet by the AIS cable by means of the connection box. The device is driven by a 24V DC 7A supply, which is connected to the power terminal at the connection box. The AIS should be connected to an emergency power source. A battery capacity calculation together with GMDSS-equipment is needed! Please refer to Appendix 9.1 for examples of battery capacity calculations.
- After performing these steps, the NAUTICAST automatically starts operation.
- The NAUTICAST has a ground terminal which has to be connected to ship ground.
- Now configure the required initial system parameters according to Chapter 4 "Starting the NAUTICAST."

## NAUTICAST

## Connection Diagram

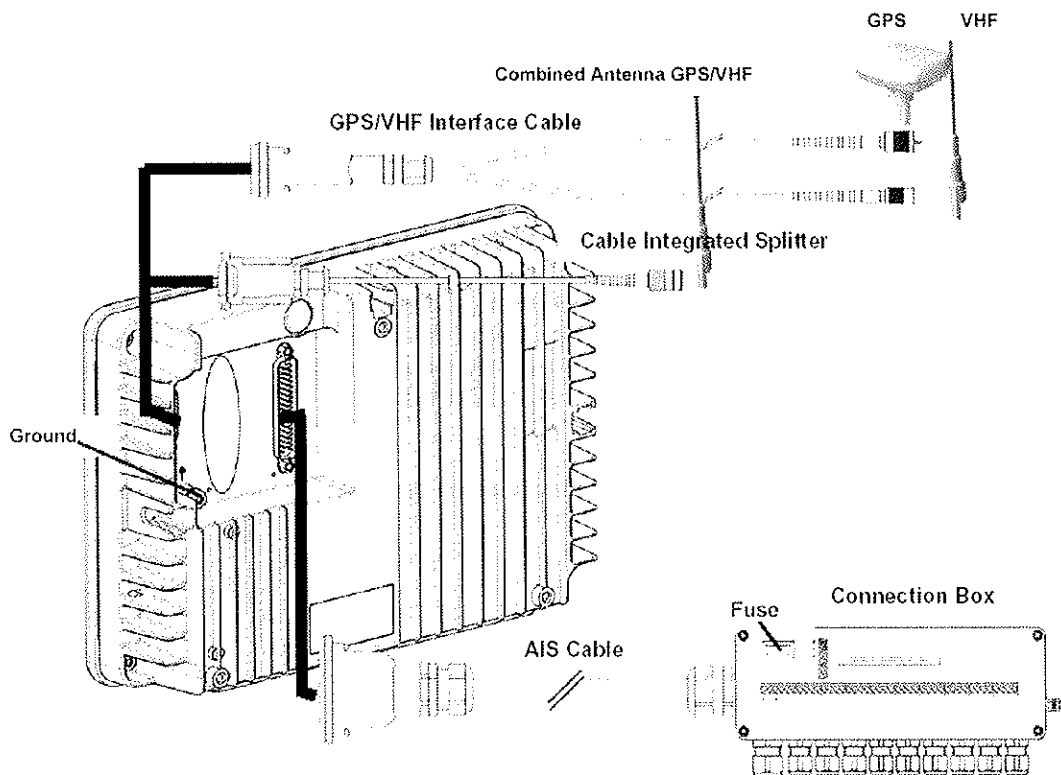

**Note:** The optional ACR connection box includes a fuse of 6,3A. If it is not used, then the unit has to be protected against high current by an external slow blow fuse of 6,3A.

## Components and Interfaces

The diagram below illustrates which devices can be connected to the NAUTICAST. For a detailed description of sensor connecting e.g. an existing Gyro to the NAUTICAST refer to Chapter 3.5 "Sensor Interface Definitions."

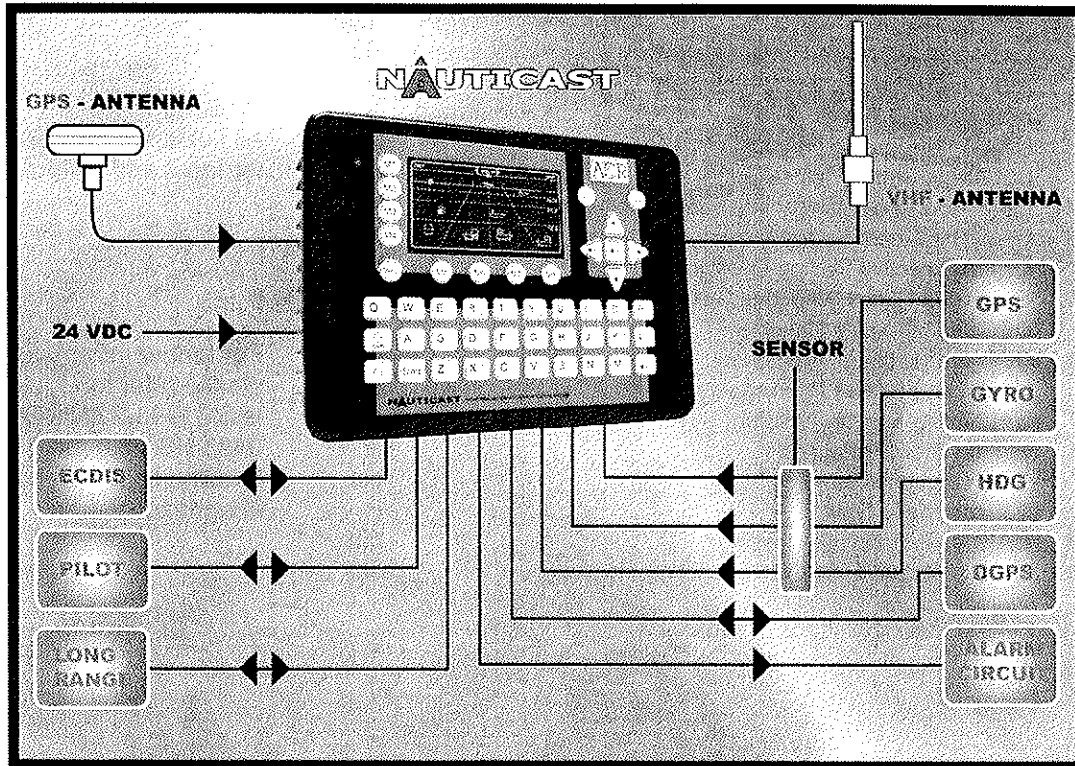

### 3.3 General Interface Description

Interface	Designation	Speed	Direction
Sensor 1	CH 1	4800bps or 38400bps	Input
Sensor 2	CH 2	4800bps or 38400bps	Input
Sensor 3	CH 3	4800bps or 38400bps	Input
ECDIS	CH 4	38400bps	Input/Output
PILOT	CH 5 / CH 15	38400bps	Input/Output
LONG RANGE	CH 8	38400bps	Input/Output
DGPS (RTCM SC104)	CH 9	9600bps	Input/Output
ALARM CIRCUIT	CH 10	Dry relay contact (power off and alarm state closed)	

### 3.4 Interface NMEA Description:

#### 3.4.1 Sensor - Interface CH1, CH2, CH3

Refer to Chapter 3.8 for detailed information on Sensor - Interface and Configuration.

#### 3.4.2 ECDIS – Presentation Interface CH 4

Sentence Formatters		Direction	Used Fields
<b>ABK</b>	UAIS Addressed and binary broadcast acknowledgement	out	All fields are provided for Input and Output.  For further information please refer to IEC 61993-2 / NMEA 0183 HS V3.0 for detailed field information.
<b>ACA</b>	AIS Channel assignment message	in / out	
<b>ACK</b>	Acknowledge Alarm	in	
<b>AIR</b>	UAIS Interrogation Request	in	
<b>ALR</b>	Set Alarm State	out	
<b>ABM</b>	UAIS Addressed binary and safety related message	in	
<b>BBM</b>	UAIS Broadcast Binary Message	in	
<b>DSC</b>	Digital Selective Calling Information	out	
<b>DSE</b>	Expanded Digital Selective Calling	out	
<b>DSI</b>	DSC Transponder Initialize	out	
<b>DSR</b>	DSC Transponder Response	out	
<b>LRI</b>	UAIS Long-Range Interrogation	out	
<b>LRF</b>	UAIS Long-Range Function	out	
<b>SSD</b>	Station Static Data	in	
<b>TXT</b>	Text Transmission	out	
<b>VSD</b>	Voyage Static Data	in	
<b>VDM</b>	UAIS VHF Data-link Message	out	
<b>VDO</b>	UAIS VHF Data-link Own-vessel report	out	

### 3.4.3 Pilot Port CH 5

The used sentence formatters for the pilot plug are the same as those listed for the ECDIS port.

**Note:**

A pilot input/output port is part of an AIS Class A installation. A plug connected to this port should be installed on the bridge near the pilot's operating position, so that a pilot can connect a Personal Pilot Unit (PPU) if required. Also, a power connector for the pilot unit should be available nearby.

The pilot plug should be configured as follows: (Refer to SUB-COMMITTEE ON SAFETY OF NAVIGATION NAV48/18 2.4.2002)

AMP/Receptacle (Square Flanged (-1) or Free-Hanging (-2)), Shell size 11, 9-pin, Std. Sex 206486-1/2 or equivalent with the following connections:

- Tx A (out-) is connected to Pin 1
- Tx B (out+) is connected to Pin 4
- Rx A (in-) is connected to Pin 5
- Rx B (in+) is connected to Pin 6
- Shield is connected to Pin 9

### 3.4.4 Long Range CH 8

The AIS long range function requires a compatible long range communication system (e.g. Inmarsat-C or MF/HF radio as part of GMDSS). This connection is required in order to activate the long range function of the AIS. Its input/output port must meet the IEC 61162-2 requirements.

Sentence Formatters		Direction
<b>LRI</b>	UAIS Long Range Interrogation	Input
<b>LRF</b>	UAIS Long-Range Function	Input / Output
<b>LR1</b>	UAIS Long-Range Reply Sentence 1	Output
<b>LR2</b>	UAIS Long-Range Reply Sentence 2	Output
<b>LR3</b>	UAIS Long-Range Reply Sentence 3	Output
Field Information: All fields are provided for input and output. For further information please refer to IEC 61993-2 / NMEA 0183 HS V3.0 for detailed field information.		

### 3.4.5 DGPS – DGNSS Channel 9

Field / Protocol information:

All fields are provided with further information; please refer to ITU-R M.823-2 / RTCM SC 104 for detailed field information.

### 3.4.6 Alarm Circuit – BIIT Channel 10

The AIS requires that an alarm output (relay) must be connected to an audible alarm device or the ships alarm system, if available.

Alternatively, the BIIT (built-in integrity test) alarm system may use the alarm messages output on the presentation port (ECDIS Port Channel 5), provided the ECDIS alarm system is connected and AIS compatible.

### 3.4.7 Proprietary Sentences

The proprietary ACR NMEA sentences have the NMEA registered manufacture talker ID “NAU”. The \$PNAU sentences are an addition to the standard sentences and offer other manufactures full remote control to the Transponder. The additional “Extended NMEA command set” – manual, which could be requested on demand, includes the full description of how to use the proprietary NAUTICAST sentences.

#### Proprietary NMEA-Sentences \$PNAU

- MID - Mobile (MMS) Id
- ASD - Advanced Ship Data
- RCS - Read Configuration Settings
- STO - Set Transponder Options
- TSI - Transponder State Information
- SCR - Sensor Configuration Request
- SCA - Sensor Configuration Acknowledge
- SCD - Sensor Configuration Data
- SCM - Sensor Configuration Mode
- AIQ - Request status information from the Transponder

## 3.5 Sensor Interface Definitions

All interface ports of the NAUTICAST comply with IEC-61162-1 / -2 and NMEA-0183 HS 3.0 specifications (aligned to RS422 parameters).

### 3.5.1 Talker drive circuits

The maximum output current is  $I_{\max} = 50\text{mA}$  on each port. The drive circuit meets the requirements of ITU-T V.11.

### 3.5.2 Listener Receiver Circuits

Multiple listeners may be connected to a single talker. Optional termination resistors (120Ohm) for the input lines are provided in the connection box. The input terminals A, B and C are electrically isolated from the remaining electronics of the listening device. The input impedance is 30kOhm between A and B lines, disregarding the connection of termination resistors. The minimum input voltage is  $\pm 0,3\text{V}$ . The listener's receiver circuit complies with ITU-T V.11.

### 3.5.3 Electrical isolation

There are no direct electrical connections between the signal lines A and B. The signal ground C must not be connected to the ship main ground or power line! This isolation is in accordance with IEC 60945.

### 3.5.4 Maximum voltage on the bus

The maximum applied voltage between signal lines A and B and between either line and ground C is in accordance with ITU-T V.11. For protection against incorrect wiring and for unintended connection to older TALKER models, all receiver circuit devices are capable of withstanding 15 V between both lines and signal ground for an indefinite period.

### 3.5.5 Data transmission

Data is transmitted in serial asynchronous form in accordance with IEC 61162-1. The first bit is a start bit, and is followed by data bits, whereby the least significant bit is first.

The following parameters are used:

- Baud rate 38 400 (bits/s) 9600 (bits/s) 4 800 (bits/s)
- Data bits 8 (D7 = 0), parity none
- Stop bits 1.

## 3.6 Sensor notes

### ***External Sensor***

The AIS has interfaces (configurable as IEC 61162-1 or 61162-2) for position, bottom track (BT) speed, heading and rate of turn (ROT) sensors. In general, sensors installed in compliance with other carriage requirements of SOLAS Chapter V should be connected to the AIS System.\*1. The sensor information transmitted by AIS should be the same information being used for navigation of the ship. Interfacing problems might occur if the existing on board sensors do not have serial (IEC 61162) outputs. A converter is needed to translate the non conform data to IEC 61162 – sensor data. For Example ACR Converter type P/N 2641.

\*1) The fact that AIS is fitted on board a vessel does **NOT** entail the need to install additional sensors other than those stated in the carriage requirements.

### ***External GPS***

GNSS position sensors normally have IEC 61162 outputs suitable for direct AIS interfacing. However, it is important to note that:

- The Geodetic Datum of the position data is transmitted by the sensor in WGS84 so that an IEC 61162 DTM sentence is configured.
- AIS is able to process two reference points for its antenna position, one for external, and one for an internal sensor. If more than one external reference point is used, the appropriate information needs to be input to the AIS, so that the reference point information is suitably adjusted.

### ***External Heading***

A gyrocompass providing heading information is a mandatory sensor input to the AIS. A converter unit (synchro or step-signal converter to NMEA 0183 v.3.0 for example ACR Converter type P/N 2641 will be needed for AIS connection in the case that the ship's gyrocompass does not provide IEC 61162 output.

### ***External Speed and Course***

If a bottom track (BT) log for Speed Over Ground (SOG) is available, it may be connected. A converter (for example ACR Converter type P/N 2641) is needed if the BT-log does not provide IEC 61162 outputs.

### ***External Rate of Turn***

Not all ships will carry a Rate-Of-Turn (ROT) indicator according to IMO A.526. However, if a rate-of-turn indicator is available and it includes an IEC 61162 interface, it should be connected to the AIS.

If ROT information is not available from a ROT indicator, it may (optionally) be derived from heading information through:

- The gyrocompass itself,
- An external converter unit (see Heading),
- The AIS itself (calculated ROT).



### 3.7 Sensor Hardware Installation:

#### 3.7.1 Installation of an RS422 serial interface:

In most cases, the output from a GPS is already being used by existing navigation equipment. It is possible to split an RS 422 output for two devices. If the signal becomes too low, then an NMEA splitter has to be used.

Example for single talk multi-listener connection:

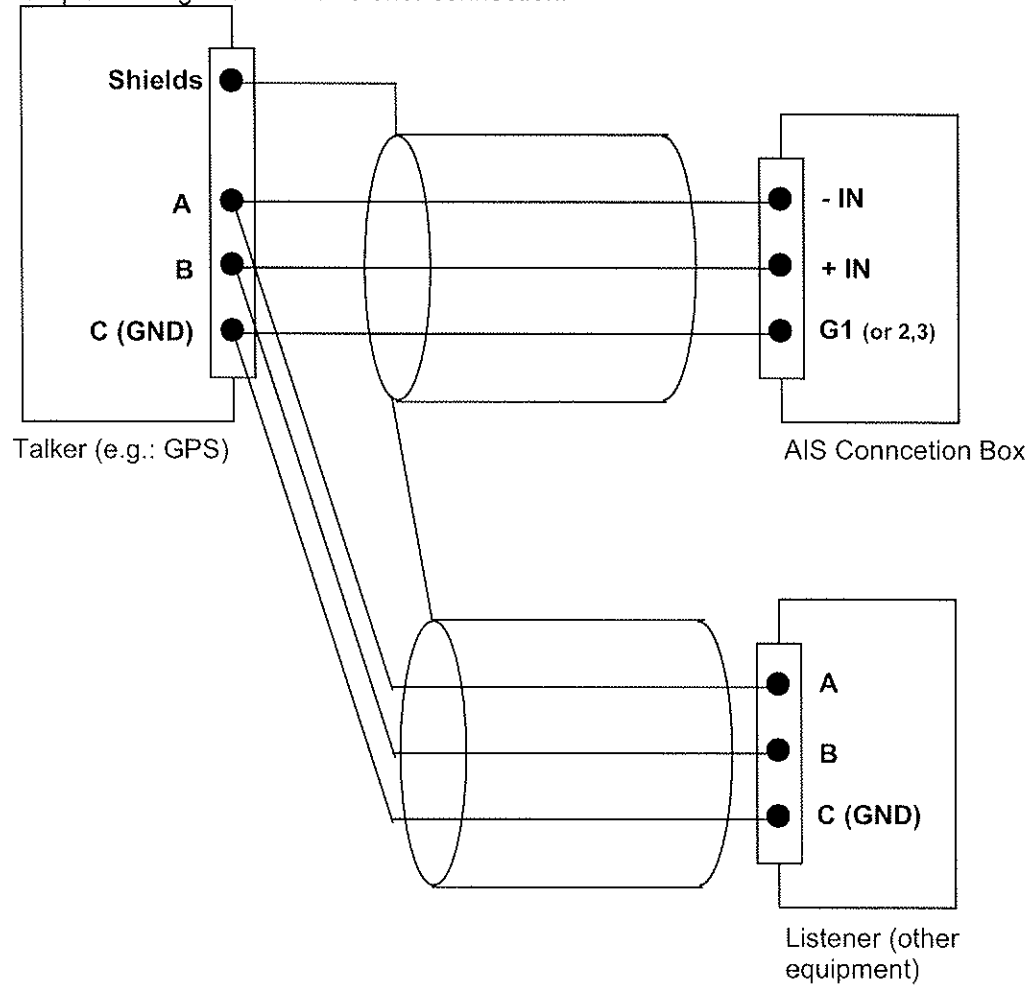

Each interface on the Transponder is a RS422 serial interface  
The shield or ship main ground should not be connected with the signal ground (GND).

## 3.8 Sensor Software Configuration

### 3.8.1 Introduction

The NAUTICAST AIS requires a connection to various sensor devices. Sensor Configuration should enable compatibility with existing navigation devices aboard any vessel.

This chapter deals with several ways to configure the NAUTICAST and to comply with the requirements of the specific sensor interfaces.

Configuration and display is visible on two screens of the Sensor Configuration Menu. The NAUTICAST offers the following configuration options:

- Set up data speed 4800/9600/38400 baud.
- Monitor the connected sensor inputs for each sensor channel.
- Verify and edit the Sensor Configuration on the display screen.
- Analyze the information received from the connected sensor devices.
- Produce an electronic installation report.
- Configuration of various NMEA protocols.

The individual options may be repeated until the required configuration for the connected sensor devices is achieved.

During the configuration process, the NAUTICAST is not operational.

### 3.8.2 Set up Sensor Speed, Checksum (CRC) and NMEA Talker and Sentence ID

Sensor configuration is available in the AIS software versions higher than 2.0.1.0. It is accessible via the new submenu '5. Sensor Settings' in the Service Password protected menu: '5. Transponder Configuration'.

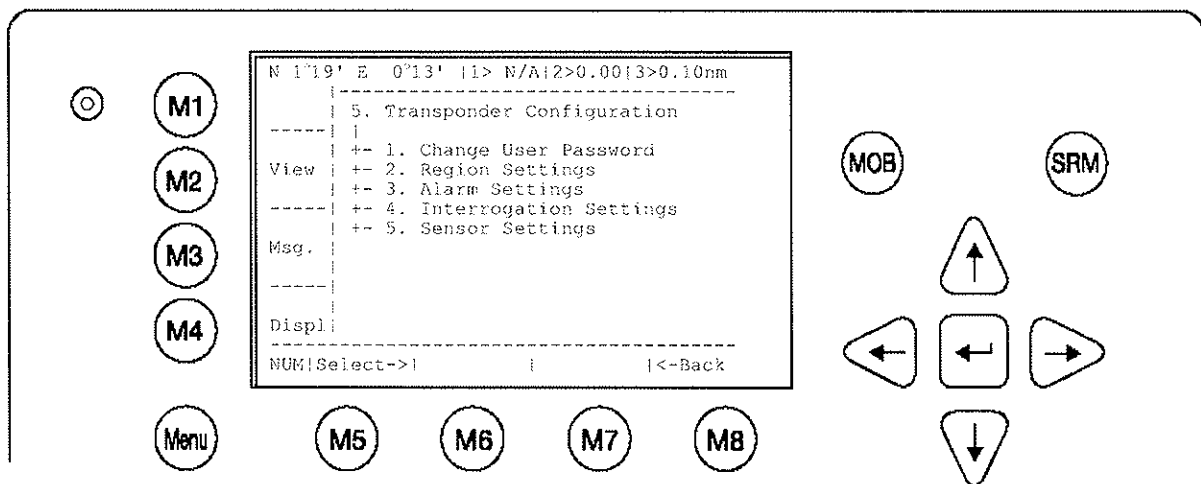



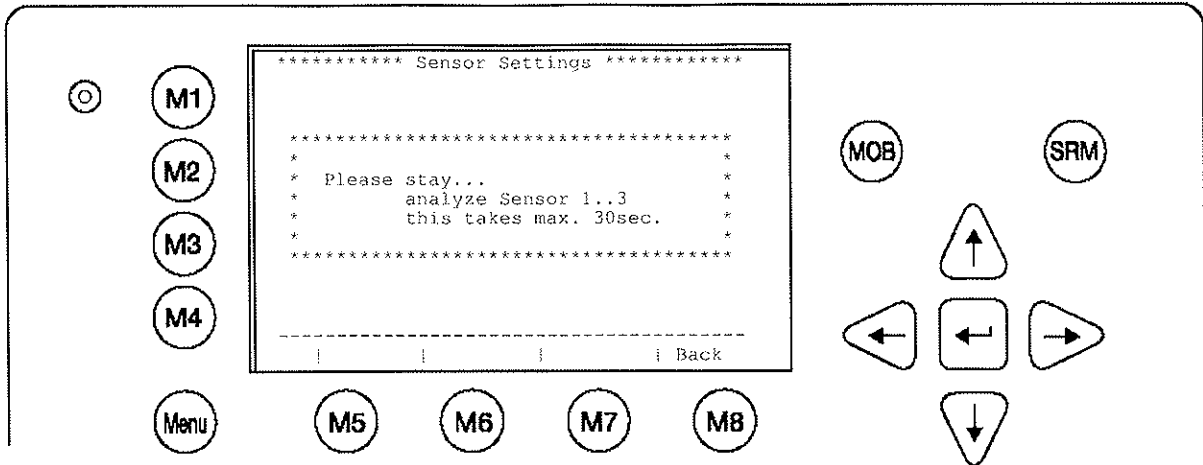

It is possible to interrupt this process by pressing the "Back" - Button [M8].  
 After the analysis is complete, the Transponder will list the data used for the AIS operation.

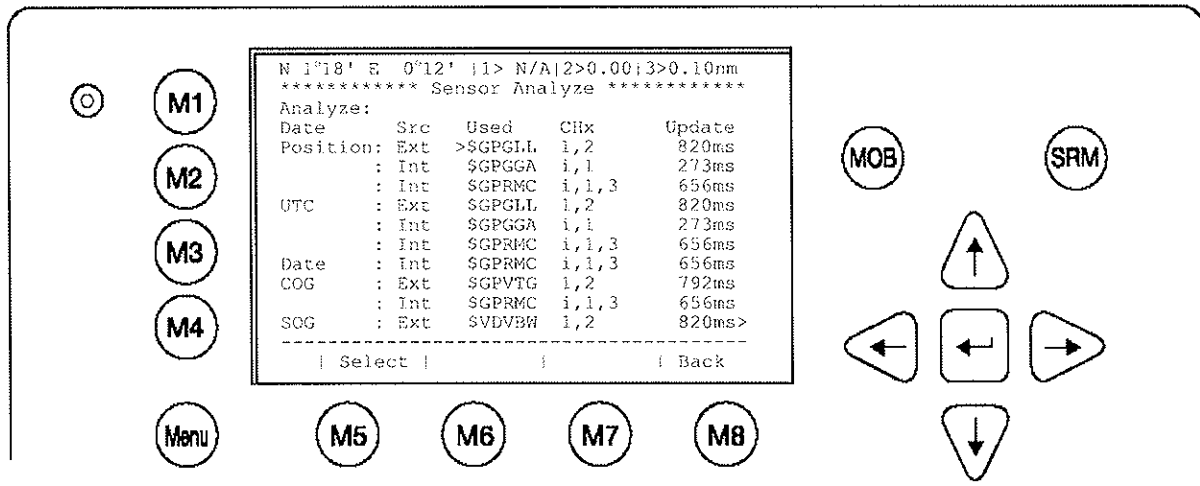



Each time the analysis process for sensor configuration is undertaken; a trace file (see below) is automatically generated and sent out to the ECDIS-Port. This output can also be used as a Sensor Configuration Report.

```

$PNAUSCA,4800,4800,4800,1
$PNAUSCD,----- Sensor Settings -----
$PNAUSCD,Date      : 06/22/2004 08:57:05
$PNAUSCD,Hardware: AIS Transponder Class A
$PNAUSCD,Software: 2.0.0.11R3
$PNAUSCD,SW Stamp: Jun 14 2004 11:46:10
$PNAUSCD,LAT      : N 53 30.123' LON : E 10 1.234'
$PNAUSCD,Heading : ExtHDT:0      iRot : 0'/min
$PNAUSCD,IMO No.  : 303174162  MMSI: 2222222
$PNAUSCD,ShipName: U4 CS      : D11233
$PNAUSCD,ShipType: Pilot vessel
$PNAUSCD,Length  : 220m  Beam: 43m
$PNAUSCD,RefPtExt: A200 B20 C10 D33m
$PNAUSCD,RefPtInt: A190 B30 C20 D23m
$PNAUSCD,Cargo   : N/A or harmless
$PNAUSCD,Draught : 24.8m
$PNAUSCD,Dest.   : CASABLANCA
$PNAUSCD,ETA     : 10/13 12:31
$PNAUSCD,NavStat : Engaged in fishing
$PNAUSCD,EPFDType: GPS
$PNAUSCD,----- Sensor Settings -----
$PNAUSCD,BaudRate Sensor1: 4800  CRC:auto
$PNAUSCD,Ignored:$-----$-----$-----
$PNAUSCD,          :$-----$-----$-----
$PNAUSCD,BaudRate Sensor2: 4800  CRC:auto
$PNAUSCD,Ignored:$HC---$-----$-----$-----
$PNAUSCD,          :$-----$-----$-----
$PNAUSCD,BaudRate Sensor3: 4800  CRC:auto
$PNAUSCD,Ignored:$HC---$-----$-----$-----
$PNAUSCD,          :$-----$-----$-----
$PNAUSCD,----- Sensor Settings -----
$PNAUSCD,Analyze:
$PNAUSCD,Date      Src  Used  CHx    Update
$PNAUSCD,Position: Ext  $GPGLL 1      955ms
$PNAUSCD,UTC       : Int  $GPGGA i      952ms
$PNAUSCD,Date     : Int  $GPRMC i      951ms
$PNAUSCD,COG      : Ext  $VDVBW 1  Calc  952ms
$PNAUSCD,SOG      : Ext  $VDVBW 1  Calc  952ms
$PNAUSCD,Heading : Ext  $TIHDT 1      953ms
$PNAUSCD,ROT      : Ext  $TIROT 1      949ms
$PNAUSCD,----- Sensor Settings -----
$PNAUSCD,Monitoring Sensor Channel 1
$PNAUSCD,[08:56:35,000] $TIROT,0.0,A
$PNAUSCD,[08:56:35,255] $GPGLL,5330.1234,N,01001
$PNAUSCD,.2345,E,141800.00,A,A
$PNAUSCD,[08:56:35,410] $GPVTG,350.0,T,,M,10.0,N
...
...
$PNAUSCD,[08:49:50,806] $TIHDT,359.9,T
$PNAUSCD,----- ROT -----
$PNAUSCD,$TIROT ext. on Ch1 :ROT
$PNAUSCD,
$PNAUSCD,Sentence   : ROT      Talker : TI
$PNAUSCD,Update Rate: 949ms  ChkSum : N/A
$PNAUSCD,Used Fields: 1,2
$PNAUSCD, 1:Rate Of Turn
$PNAUSCD, 2:Data Valid
$PNAUSCD,
$PNAUSCD,[08:49:52,900] $TIROT,0.0,A
$PNAUSCD,[08:49:51,950] $TIROT,0.0,A
$PNAUSCD,[08:49:51,001] $TIROT,0.0,A
$PNAUSCD,
$PNAUSCD,----- Sensor Settings -----

```



### 3.8.5 Priority Handling of Sensor Sentence

This table shows the priority handling of NMEA sentences. The sentences which are treated with higher priority are listed first.

Positioning System	Source	Priority
HIGH		
Time of Position		↓
Latitude/Longitude	GNS	
Position accuracy	GLL	
	GGA	
	RMC	
Rate of Turn (ROT)	ROT	
Reference Datum	DTM	
Speed over Ground	VBW	
	VTG	
	OSD	
Heading	HDT	
	OSD	
RAIM Indicator	GBS	
LOW		

### 3.8.6 Supported NMEA-0183 Sentences

#### DTM - Reference

```

      1   2 3   4 5   6 7   8   9
      |   | |   | |   | |   |   |
$--DTM,ccc,a,x.x,a,x.x,a,x.x,ccc*hh<CR><LF>

```

#### Field Numbers:

- 1) Local datum code (W84,W72,S85,P90,999-user defined, IHO datum code)
- 2) Local datum subdivision code
- 3) latitude offset, minutes
- 4) N or S (North or South)
- 5) longitude offset, minutes
- 6) E or W (East or West)
- 7) altitude offset, meters
- 8) Reference datum code ((W84,W72,S85,P90)
- 9) CRC

#### Used Fields: 1,8

- 1: Local datum code
- 8: Reference datum code

#### GGA - Positioning System Fix Data

Time, Position and fix related data from GPS receiver.

```

                                     11
      1           2           3 4           5 6 7 8   9 10 | 12 13 14 15
      |           |           | |           | | | |   | | | |   |
$--GGA,hhmmss.ss,llll.ll,a,yyyy.yy,a,x,xx,x.x,x.x,M,x.x,M,x.x,xxxx*hh

```

#### Field Numbers:

- 1) UTC
- 2) Latitude
- 3) N or S (North or South)



- 4) Longitude
- 5) E or W (East or West)
- 6) GPS Quality Indicator,
  - 0 - fix not available,
  - 1 - GPS fix,
  - 2 - Differential GPS fix
- 7) Number of satellites in view, 00 - 12
- 8) Horizontal Dilution of precision
- 9) Antenna Altitude above/below mean-sea-level (geoid)
- 10) Units of antenna altitude, meters
- 11) Geoidal separation, the difference between the WGS-84 earth ellipsoid and mean-sea-level (geoid), \- \ means mean-sea-level below ellipsoid
- 12) Units of geoidal separation, meters
- 13) Age of differential GPS data, time in seconds since last SC104 type 1 or 9 update, null field when DGPS is not used
- 14) Differential reference station ID, 0000-1023
- 15) CRC

Used Fields: 1,2,3,4,5,6,7  
 1:UTC 2:Lat 3:LaInd 4:Lon  
 5:LoInd 6:Acc 7:Sat

GLL - Position - Latitude/Longitude

```

      1      2 3      4 5      6 7 8
      |      | |      | |      | | |
$--GLL,llll.ll,a,yyyy.yy,a,hmmss.ss,A,a*hh<CR><LF>

```

Field Numbers:

- 1) Latitude
- 2) N or S (North or South)
- 3) Longitude
- 4) E or W (East or West)
- 5) Universal Time Coordinated (UTC)
- 6) Status A - Data Valid, V - Data Invalid
- 7) Mode indicator
- 8) CRC

Used Fields: 1,2,3,4,5,6,7  
 1:Lat 2:LaInd 3:Lon 4:LoInd  
 5:UTC 6:Valid 7:Acc

GNS - Fix Data

```

      1      2      3 4      5 6      7 8      9      10 11 12 13
      |      |      | |      | |      | |      |      | | | |
$--GNS,hmmss.ss,llll.ll,a,yyyy.yy,a,c--c,xx,x.x,x.x,x.x,x.x,x.x*hh

```

Field Numbers:

- 1) UTC
- 2) Latitude
- 3) N or S (North or South)
- 4) Longitude
- 5) E or W (East or West)
- 6) Mode indicator
- 7) Total number of satellites in use,00-99
- 8) HDROP
- 9) Antenna altitude, meters, re:mean-sea-level(geoid)
- 10) Geoidal separation meters
- 11) Age of differential data
- 12) Differential reference station ID
- 13) CRC

Used Fields: 1,2,3,4,5,6,7  
 1:UTC 2:Lat 3:LaInd 4:Lon  
 5:LoInd 6:Acc 7:Sat

RMC - Minimum Navigation Information

```

          12
      1      2 3      4 5      6 7  8  9      10 11| 13
      |      | |      | |      | |  |  |      |  | | |
$--RMC,hhmmss.ss,A,llll.ll,a,yyyy.yy,a,x.x,x.x,ddmmyy,x.x,a,a*hh<CR><LF>

```

Field Numbers:

- 1) UTC Time
- 2) Status, V = Navigation receiver warning
- 3) Latitude
- 4) N or S
- 5) Longitude
- 6) E or W
- 7) Speed over ground, knots
- 8) Course over Ground, degrees true
- 9) Date, ddmmyy
- 10) Magnetic Variation, degrees
- 11) E or W
- 12) Mode Indicator
- 13) CRC

Used Fields: 1,2,3,4,5,6,7,8,9,10,11,12  
 1:UTC 2:Valid 3:Lat 4:LaInd 5:Lon 6:LoInd  
 7:SOG 8:COG 9:Date 10:MagV 11:MagIn 12:Acc

VBW - Ground/Water Speed

```

      1  2  3 4  5  6 7
      |  |  | |  |  | |
$--VBW,x.x,x.x,A,x.x,x.x,A*hh<CR><LF>

```

Field Numbers:

- 1) Longitudinal water speed, \- \ means astern
- 2) Transverse water speed, \- \ means port
- 3) Status, A = Data Valid
- 4) Longitudinal ground speed, \- \ means astern
- 5) Transverse ground speed, \- \ means port
- 6) Status, A = Data Valid
- 7) CRC

Used Fields: ,5,6  
 4:LonGS 5:TraGS 6:Valid

VTG - made good and Ground speed

```

      1  2 3  4 5  6 7  8 9 10
      |  | |  | |  | |  | | |
$--VTG,x.x,T,x.x,M,x.x,N,x.x,K,A*hh<CR><LF>

```

Field Numbers:

- 1) Track Degrees
- 2) T = True
- 3) Track Degrees
- 4) M = Magnetic
- 5) Speed Knots
- 6) N = Knots
- 7) Speed Kilometres per Hour
- 8) K = Kilometres per Hour

9) Status, A = Data Valid  
10)CRC

Used Fields: 1,5,6,7,8,9  
1:COG 5:SOG 6:SOGIn 7:SOG 8:SOGIn 9:Valid

OSD - Ship Data

```
      1  2 3  4 5  6 7  8  9 10  
      |  | |  | |  | |  |  | |  
$--OSD,x.x,A,x.x,a,x.x,a,x.x,x.x,a*hh<CR><LF>
```

Field Numbers:

- 1) Heading, degrees true
- 2) Status, A = Data Valid
- 3) Vessel Course, degrees True
- 4) Course Reference
- 5) Vessel Speed
- 6) Speed Reference
- 7) Vessel Set, degrees True
- 8) Vessel drift (speed)
- 9) Speed Units
- 10) CRC

Used Fields: 1,2,3,4,5,6,9  
1:HDT 2:HDTVal 3:COG 4:COGRef  
5:SOG 6:SOGRef 9:SOGInd

HDT - True

```
      1  2 3  
      |  | |  
$--HDT,x.x,T*hh<CR><LF>
```

Field Numbers:

- 1) Heading Degrees, true
- 2) T = True
- 3) CRC

Used Fields: 1,2  
1:HDT 2:HDTRu

ROT - Of Turn

```
      1  2 3  
      |  | |  
$--ROT,x.x,A*hh<CR><LF>
```

Field Numbers:

- 1) Rate Of Turn, degrees per minute, \- means bow turns to port
- 2) Status, A means data is valid
- 3) CRC

Used Fields: 1,2  
1:ROT 2:Valid

### 3.8.7 Calculated Values

Processed dynamic ship data such as position, SOG etc. is generated by NMEA sentences.

Exceptions:

If "Calc" is displayed on the sensor analyze screen, this means that this sentence is used for calculating dynamic ship data.

#### ROT out of HDT

ROT direction left / right +/- will be calculated out of the HDT Message, if a TIROT sentence (only "TI"-Talker devices are valid) is not connected.

ROT > +10°/min	→	Output +720°/min
ROT < -10°/min	→	Output -720°/min
Other	→	Output 0°/min

#### COG information out of VBW

COG will be generated out of VBW, if HDT is available. In this case the atan2 of the longitudinal and transversal speed plus heading is basis of the calculation.

#### Longitudinal/Transversal SOG from VBW

If VBW is available, SOG is also calculated without HDT.

### 3.8.8 Versions of NMEA Sentences

#### RMC

v2.30 - \$GPRMC,122500.00,A,5330.1234,N,01001.2345,E,11.2,352.2,120202,2.0,E,A  
v2.20 - \$GPRMC,122500.00,A,5330.1234,N,01001.2345,E,11.2,352.2,120202,2.0,E

#### GLL

v2.30 - \$GPGLL,5330.1234,N,01001.2345,E,141800.00,A,A  
v2.00 - \$GPGLL,5330.1234,N,01001.2345,E,141800.00,A  
v1.50 - \$GPGLL,5330.1234,N,01001.2345,E

#### GGA

v2.00 - \$GPGGA,092854,5330.1234,N,01001.2345,E,1,3,1.2,65.2,M,45.1,M,,  
v1.50 - \$GPGGA,092854,5330.1234,N,01001.2345,E,1,3,1.2,65.2,M,45.1,M

#### VBW

v2.30 - \$VDVBW,11.00,01.00,A,12.00,02.00,A,,V,,V  
v2.20 - \$VDVBW,11.00,01.00,A,12.00,02.00,A

#### VTG

v2.30 - \$GPVTG,350.0,T,,M,10.0,N,,K,A  
v2.20 - \$GPVTG,350.0,T,,M,10.0,N,,K

#### OSD

v2.30 - \$INOSD,359.9,A,5.2,B,12.6,B,150.0,1.2,N  
v2.20 - \$INOSD,359.9,A,5.2,B,12.6,B,150.0

### 3.9 Pin-Description AIS-Cable / Socket 50-Pins:

TxA → out –  
 TxB → out +  
 RxA → in –  
 RxB → in +

AIS Cable/Socket ( Sub-D 50 Plug )					
1	CH5_out+			34	Spare
		18	Ch4_out+		
2	CH5_out-			35	Spare
		19	CH4_out-		
3	CH5_gnd			36	Spare
		20	CH4_gnd		
4	CH5_in+			37	Spare
		21	CH4_in+		
5	CH5_in-			38	Spare
		22	CH4_in-		
6	CH6_Vin			39	CH9_gnd
		23	CH8_in+		
7	CH6_gnd			40	CH9_out-
		24	CH8_in-		
8	CH6_CANL			41	CH9_in-
		25	CH8_gnd		
9	CH6_CANH			42	CH9_in+
		26	CH8_in+		
10	CH1_in-			43	CH9_out+
		27	CH8_in-		
11	CH1_gnd			44	Spare
		28	Spare		
12	CH1_in+			45	Spare
		29	CH3_in-		
13	CH2_in-			46	CH10_1
		30	CH3_gnd		
14	CH2_gnd			47	CH10_2
		31	CH3_in+		
15	CH2_in+			48	Vin_gnd
		32	Vin_gnd		
16	Vin+ (24V)			49	Vin_gnd
		33	Vin+ (24V)		
17	Vin+ (24V)			50	Spare
CH1	Sensor	CH4	ext. Display	CH8	Long Range
CH2	Sensor	CH5	aux. Display	CH9	DGNSS BIIT / Relay
CH3	Sensor	CH6	opt. 61162-3	CH10	(max. 30V DC / 1A)
Spare	Do not use				

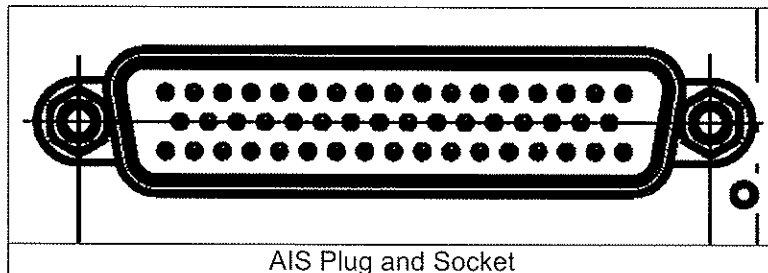

### 3.10 Pin-Description AIS-Connector:

Black BK  
 White WH  
 Red RD  
 Green GN  
 Brown BR  
 Blue BL  
 Orange OR  
 Yellow YL  
 Violet VI  
 Gray SL(Slate)  
 Pink PK

AIS -Cable Sub-D 50 Plug

Note:  
 TxA → out -  
 TxB → out +  
 RxA → in -  
 RxB → in +

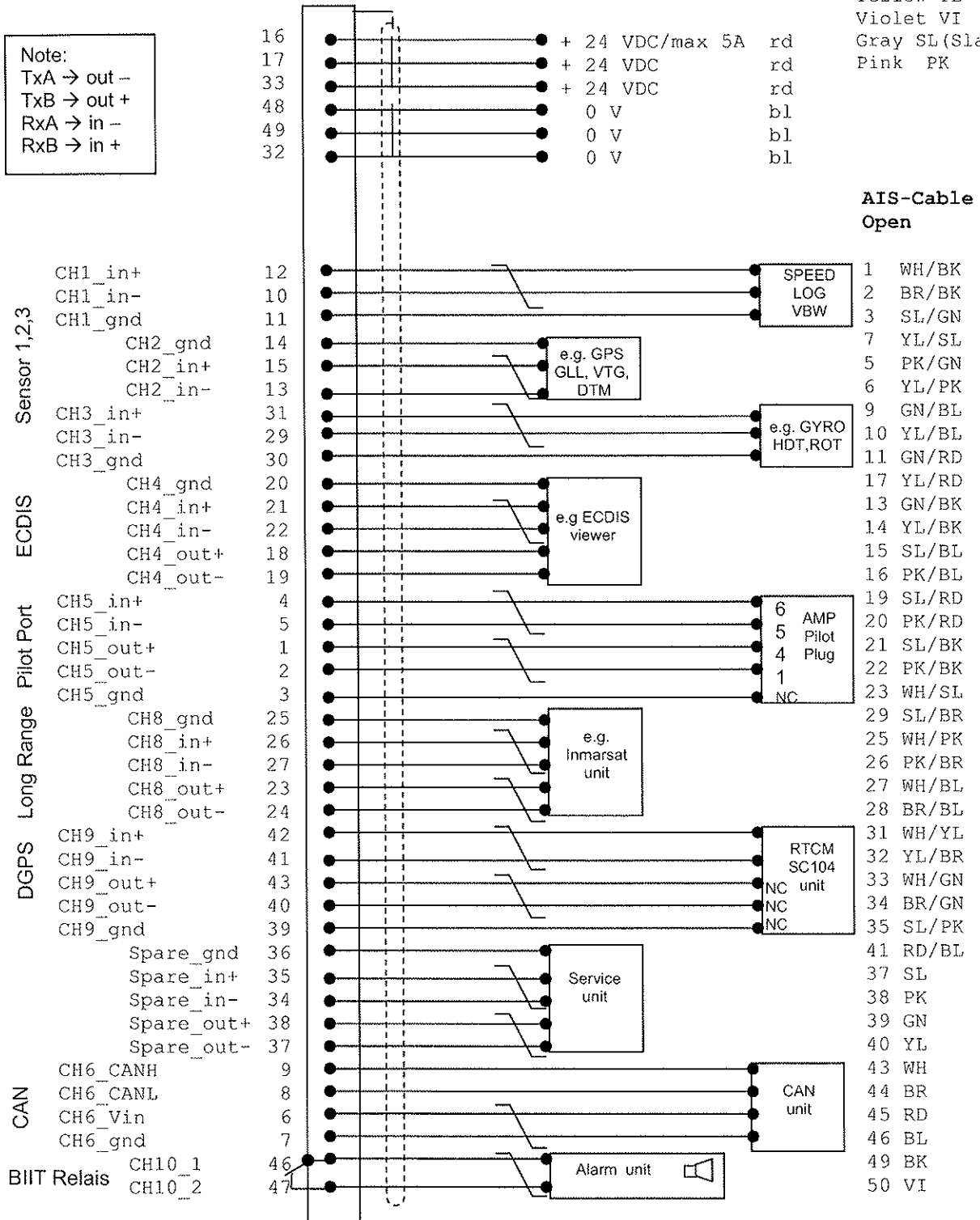

### 3.11 Pin-Description Communication-Cable / Socket 50-Pins

Communication-Cable / Socket ( Sub-D 50 Socket )					
1				34	
		18			
2				35	
		19			
3				36	
		20			
4				37	
		21			
5				38	
		22			
6				39	
		23			
7				40	
		24			
8				41	
		25			
9				42	
		26			
10				43	
		27			
11				44	Blue Sign - Switch
		28	Blue Sign - Switch		
12				45	
		29			
13				46	
		30			
14				47	
		31			
15	CH15_TxD			48	
		32	CH15_RxD		
16				49	CH15_GND
		33			
17				50	
CH15	Communication RS232				
Spare	Do not use				

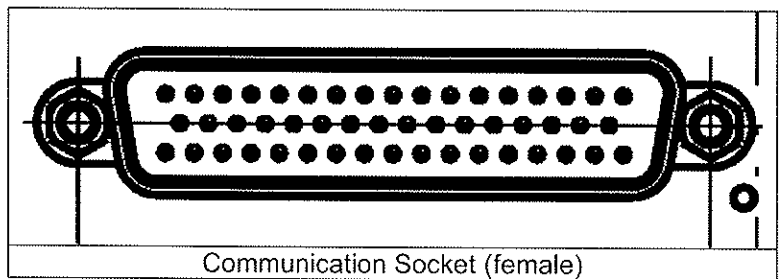

### 3.12 Communication Cable RS232 (Sub-D 50 Socket)

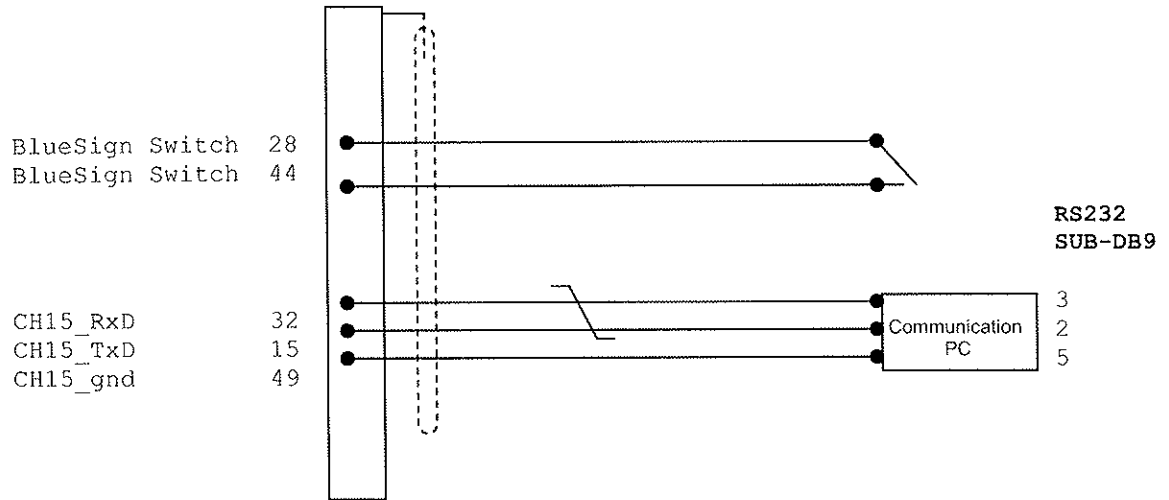



## 3.13 Installation of VHF / GPS Antennas

### Interference to the Ship's VHF Radiotelephone

The AIS ship borne equipment, like any other ship borne transceiver operating in the VHF maritime band, may cause interference to a ship's VHF radiotelephone. Because AIS is a digital system, this interference may occur as a periodic (e.g. every 20 seconds) soft clicking sound on the ship's radiotelephone. This affect may become more noticeable if the VHF radiotelephone antenna is located close to the AIS VHF antenna, and when the radiotelephone is operating on channels near the AIS operating channels (e.g. channels 27, 28 and 86).

Attention should be paid to the location and installation of the various antennas, in order to support the antenna characteristics in the best possible way.

#### 3.13.1 VHF Antenna Installation

##### Antenna Location

Location of the mandatory AIS VHF-antenna should be carefully considered. Digital communication is more sensitive than analogue/voice communication to interference created by reflections caused by obstructions such as masts and booms. It may be necessary to relocate the VHF radiotelephone antenna to minimize interference effects.

To minimize the interference effects, the following guidelines apply:

- The AIS VHF antenna should have omni directional vertical polarization providing 3 to 5 dB gain.
- The AIS VHF antenna should be placed in an elevated position, as free standing as possible, with a minimum of 2 meters in horizontal direction from constructions made of conductive materials. The antenna should not be installed close to any large vertical obstruction. The AIS VHF antenna should have a visible sky of 360°.
- The AIS VHF antenna should be installed at least 3 meters away from interfering high-power energy sources such as radar and other transmitting radio antennas, and out of the way of the transmitting beam.
- There should not be more than one antenna on each level. The AIS VHF antenna should be mounted directly above or below the ship's primary VHF radiotelephone antenna, with no horizontal separation and a minimum of 2 meters vertical separation. If it is located on the same level as other antennas, the distance apart should measure at least 10 meters.

See also sample for antenna layout in the Appendix (Drawings and Approvals)

##### Cabling

The cable should be kept as short as possible to minimize attenuation of the signal. Double shielded coaxial cables equal to or better than RG214 is recommended. RG214 at VHF attenuation per meter of app. 0,07 dB/m (45m = 3,15db)  
VHF AIS frequency app. 162MHz

All outdoor connectors on the coaxial cables should be fitted with preventive isolation, such as shrink-stocking with silicone to protect the antenna cable against water penetration. Coaxial cables should be installed in separate signal cable channels/tubes, and at least 10 cm away from any power supply cables. Crossing of cables should take place at right angles (90°). Coaxial cables should not be exposed to sharp bends, which may lead to changes to the characteristic impedance of the cable. The minimum bend radius should be 5 times the cables outside diameter.

## **Grounding**

Coaxial down-leads must be used for all receiving antennas, and the coaxial screen should be connected to the ground at one end.

### **3.13.2 GNSS Antenna installation**

A Class A AIS must be connected to a GNSS antenna.

#### **Location**

The GNSS antenna must be installed where it has a clear view of the sky, so that it accesses the horizon freely through 360°, with a vertical observation of 5 to 90 degrees above the horizon. Small diameter obstructions, such as masts and booms, do not seriously impair signal reception, but such objects must not eclipse more than a few degrees of any given bearing.

The antenna must be located at least three meters away from, and out of the transmitting beam of high-power transmitters (S-Band Radar and/or Inmarsat systems). This includes the ship's own AIS VHF antenna, if it is designed and installed separately. See also sample for antenna layout in Installation Manual Appendix 8.2 (Drawings)

If a DGNSS system is included or connected to the AIS system, the installation of the antenna should be undertaken in accordance with IEC 61108-4, Edition 1.

#### **Cabling**

To achieve optimum performance, the gain of the antenna pre-amplifier should match the cable attenuation. The resulting installation gain (pre-amplifier gain - cable attenuation) should be within 0 to 10 dB (RG214 at GPS attenuation per meter of app. 0.35 dB/m (45m = 15.75dB); GPS frequency app. 1.2GHz).

The coaxial cable between the antenna and the AIS ship borne station connector should be routed directly, in order to reduce electromagnetic interference. The cable should not be installed close to high-power lines, such as radar or radio-transmitter lines, or near the AIS VHF antenna cable. A space of one meter or more is recommended in order to avoid degradation due to RF-coupling. Crossing of antenna cables should take place at 90 degrees, to minimize magnetic field coupling.

#### **Attenuation**

As described above, the resulting installation gain should be between 0 to 10 dB. If the internal GPS receiver will be overloaded with more than 18 dB, then it could be damaged.

## Attenuation values

Type	Name	Part number	Total gain
GPS-Antenna	GPS-Antenna Marina 2	2625	+35dBi
GPS-Antenna	Procom GPS4	2622	+35dBi
Comb. GPS/VHF-Antenna	Comrod AC-17	2624	+20dBi (GPS amp gain)
Cable	RG214	2630	-15.75 dB
Adapter	GPS-VHF Adapter cable with 1m RG58 / TNC connector	2612	-1dB
Connector	TNC plug RG214 crimp	2633	-0.1dB

## Example

Procom GPS4	+ 35.00dBi
11m RG214 0,35 dB/m	- 3.85dB
maybe 2 TNC plugs	- 0.20dB
Nauticast with Adapter P/N 2610	-1.00dB
Total	29.95dB
Necessary minimum attenuation (=> 12dB Attenuator needed!)	≥11.95dB
GPS Input	≤18.00dB

## Attention

If installations are not in compliance to this requirement we cannot guarantee operation nor accept a warranty issue.

## Antenna Layout

The position of the VHF and GNSS – antennas must be added to the existing antenna layout of the vessel.

## 3.14 Power Supply

The NAUTICAST must be supplied from the emergency power source. A further requirement is to connect AIS to the reserve power source of the GMDSS. A new battery capacity calculation must then be undertaken. See sample in 9.1 (Samples for battery calculation)

### Following documents are needed for the installation approval of the classification

- Antenna Layout (arrangement)
- Battery Calculation
- Connection / Block – Diagram with locations
- Type Approval Certificate

## 4 Starting the NAUTICAST

### 4.1 Initial Set Up of the NAUTICAST for operation

**ATTENTION: AUTHORITIES MANADATE THAT YOU ENTER THIS INFORMATION.**

After installing the antennas and hardware the following User, Voyage related and Ship Settings data needs to be entered. Upon Start-up (Applying power) enter the following information.

- a) Enter MMSI Number - See paragraph 4.2 on entering information.  
During the initial boot or after "factory settings" the user is asked to enter a valid MMSI number. As long as this is not done, the system does not transmit. This appears as Alarm-ID 56 with the text "AIS: ENTER MMSI NUMBER".

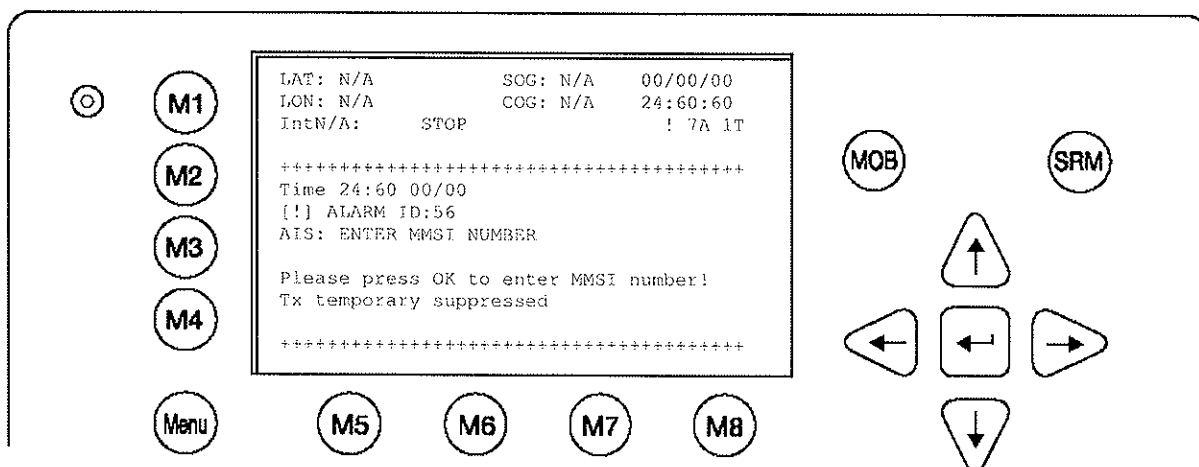

- b) Enter IMO Number, Designated Area Code (DAC) and European Ship Number (ESN)  
- See paragraph 4.2 on Entering information.
- c) Select AIS Mode – According to the local requirements you have to select the AIS Mode between Inland AIS or SOLAS AIS.  
See paragraph on altering this information.
- d) Ship Settings Data - After initial entry of the Ship Settings Data any changes in the information below should be edited accordingly. See Paragraph 4.3 on entering information.
- Enter Call Sign
  - Enter Ships Name
  - Enter Length of Ship
  - Enter Beam of Ship
  - Enter Internal GPS antenna Position
  - Enter External GPS Antenna Position (If Applicable).
  - Enter Ship Type
- e) Voyage related Data – After initial entry of the Voyage related Data any changes in the information below should be edited accordingly.  
See Paragraph 4.4 on entering information.
- Enter Cargo Type
  - Enter Draught
  - Enter Destination
  - Enter ETA
  - Enter Navigation Status.
- f) Password – Service and User passwords see section 4.5

## 4.2 Entering the MMSI / IMO / DAC / ESN Numbers

Select from the Main Menu “**Service Configuration**” **Number 6**. Menu is SERVICE password protected with default password “NAUT”. Enter Service Password and use the up and down arrows on keypad to select “Change MMSI / IMO” than press M5 “Select” or “by pressing number 3 on the keypad.

Input your MMSI and IMO number and press Save to store data. Unit will reboot itself after pressing Save. Continue to 4.2 after reboot.

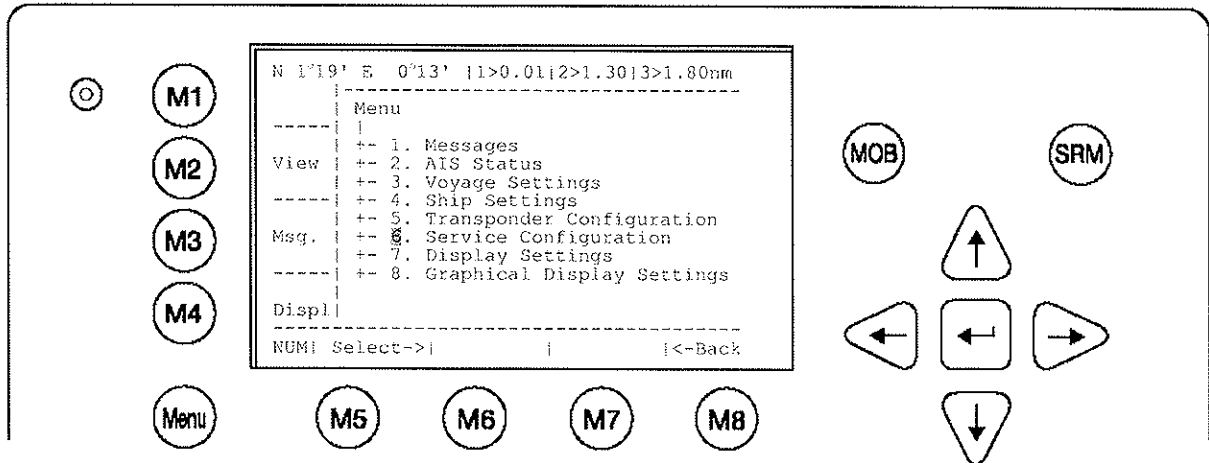

Service Configuration Menu Example:

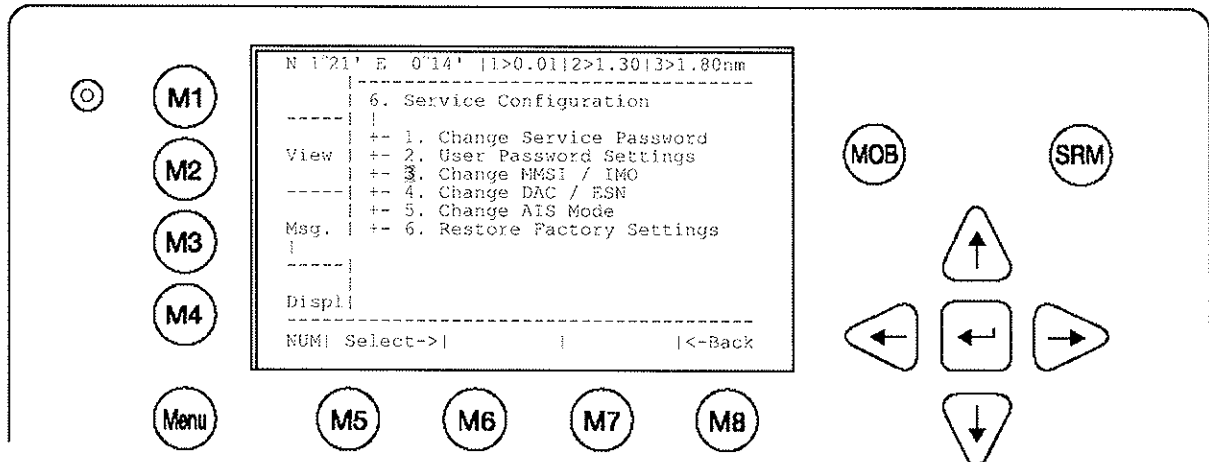

**Note:** MMSI and IMO Data input are limited to 9 characters.

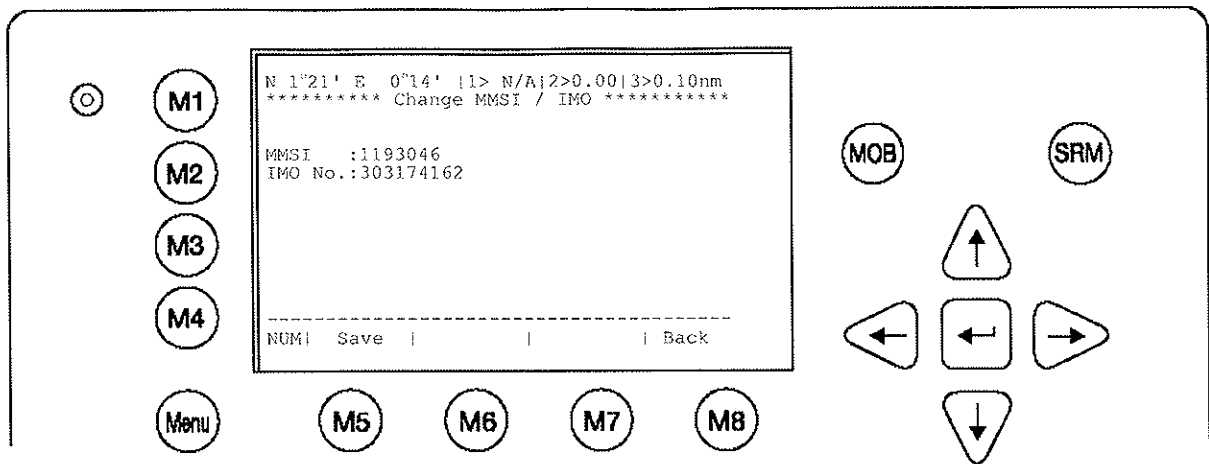

Select Submenu 4 "Change DAC / ESN" with cursor button [Up] & [Down] by pressing Nr. 4 on the keyboard.

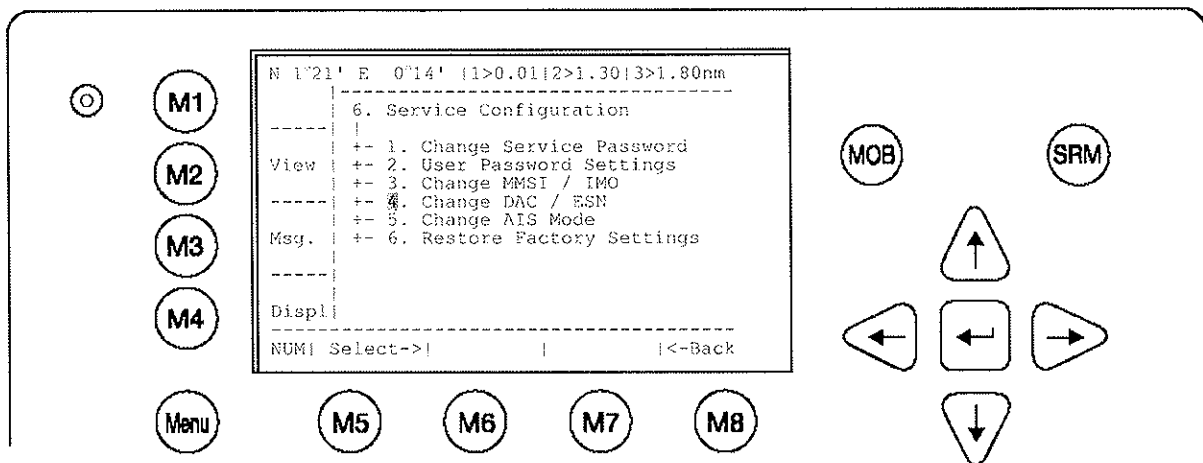

Input new DAC / ESN Numbers and press [Save] to store input data. Press [Back] to return to the Submenu without saving.

**Note:**

The DAC (Designated Area Code) is predefined with the value "200". Please key in only a different 3 digit value if your authority wants you to do this. Otherwise you may lose important AIS information. The ESN (European Ship Number) is limited to 8 ASCII characters.

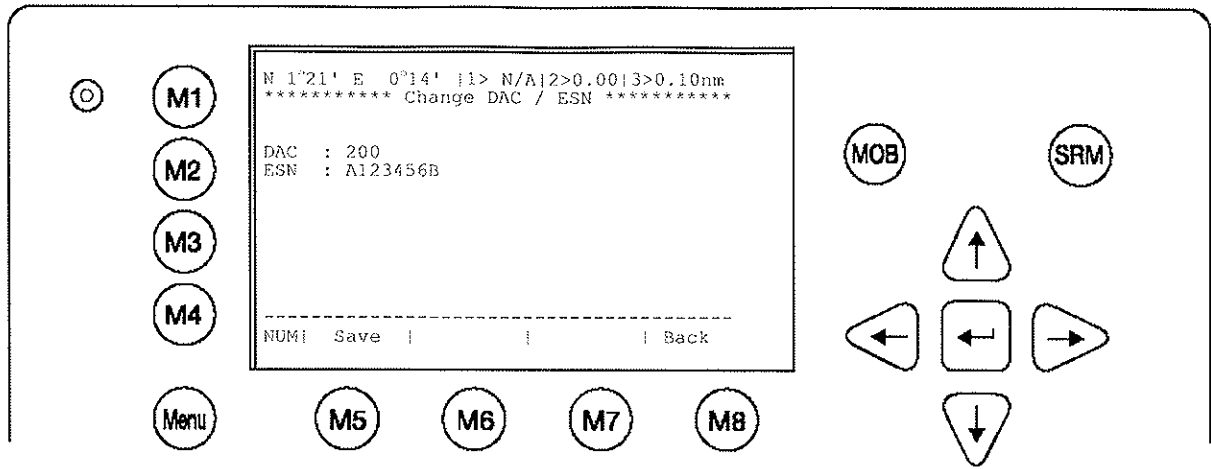

### 4.3 Entering Ship Settings

Select from the Main Menu "Ship Settings" Menu is USER password protected with default password "NAUT". Enter Password and use the up and down arrows to edit Ship Settings then press Enter or the numeric reference on the keypad to select and edit. Save after editing.

Main Menu Example:

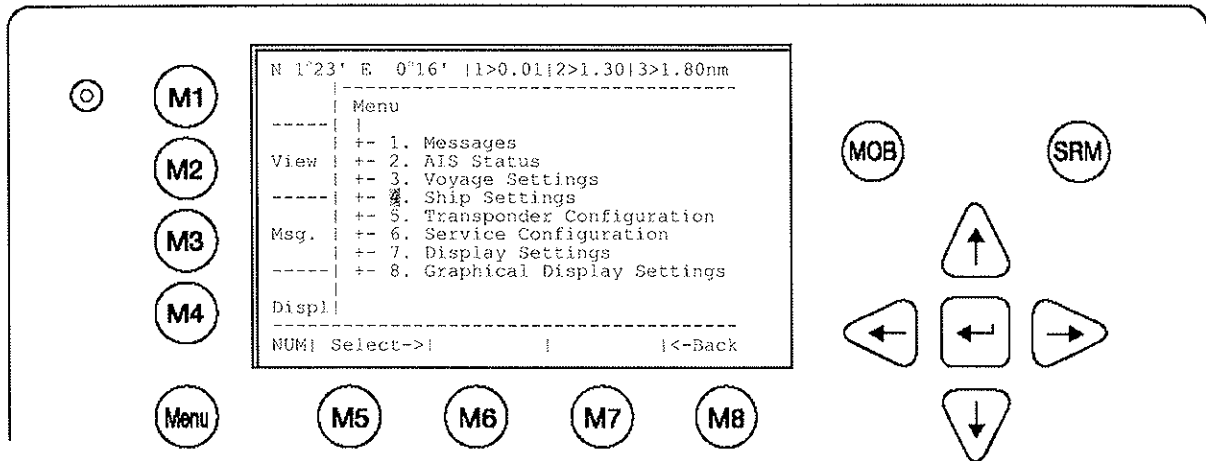

Select Ship Settings and press M5 [Enter]. Enter User Password and Continue.

Ship Settings Menu Example:

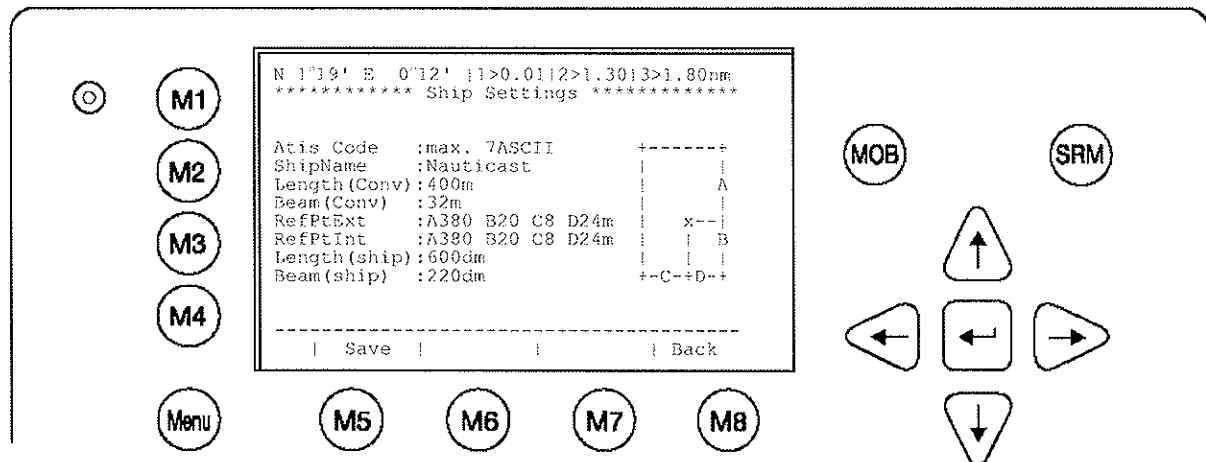

- Select and enter ATIS Code / Call Sign.
- Select and enter Ship Name.
- Select and enter Length of Convoy (in m).
- Select and enter Beam of Convoy (in m).
- Select and enter Internal and External GPS antenna positions.
- Select and enter Length of Ship (in dm).
- Select and enter Beam of Ship (in dm).



### Setting the Internal and External GPS Antenna Position.

**Note:** It is critical for the proper orientation of your ship to other AIS users to enter this data accurately.

**Example:** Length of ship = 220m and Beam = 43m.

**GPS ANTENNA** location on ship (is x in above Menu example) is located 200 meters from bow (A) and 33 Meters from Starboard side (D).

**Note:** You can only enter Dimension A and D. B and C are automatically calculated.

You would enter A200D33 (without spaces, no decimals and no commas).

Then Press Save.

The line than should look like the example above for External Reference point.

**Note:** When only using internal GPS antenna it is ok to have default values for external position since they are not used.

**RefPointExt = A200 B20 C10 D33m (Position of the external GPS antenna)**

A = the distance from bow (front) to the antenna.

B= the distance from the antenna to the stern (rear)

C = the distance from the port (left) side to the antenna

D = the distance from the antenna to the starboard (right) side

**Enter RefPtInt (location of the internal GPS antenna) in the same way.**

**Save the new settings by pressing [Save].**

Press [Back] return to the Main Menu Screen without saving any changes.

## 4.4 Entering Voyage Related Data

Select from the Main Menu "Voyage Settings" Menu is USER password protected with default password "NAUT". Enter Password and use the up and down arrows to edit Voyage Related data then press Enter or the numeric reference on the keypad to select and edit. Save after editing.

Main Menu Example:

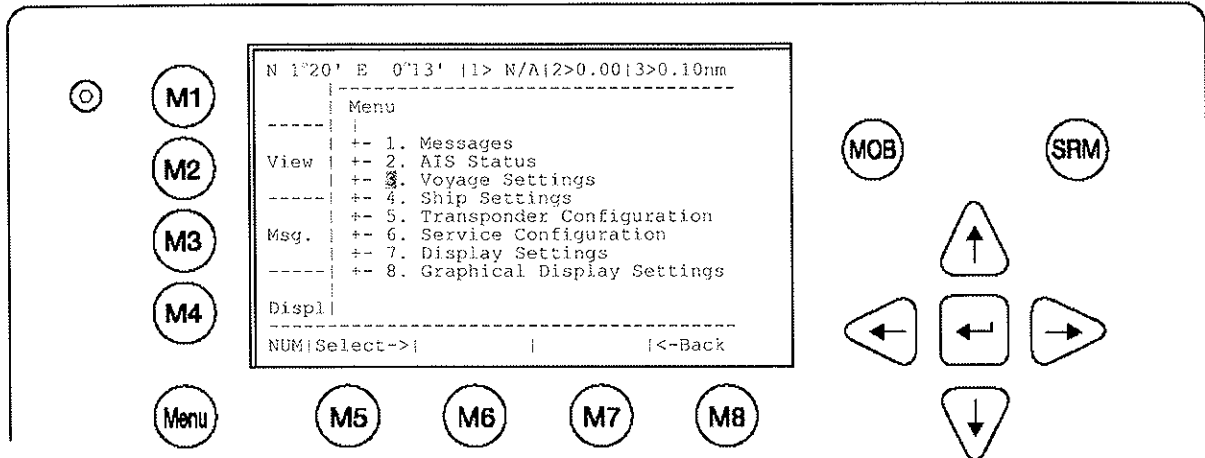

The password query field appears. Input new User Password and press [Enter].

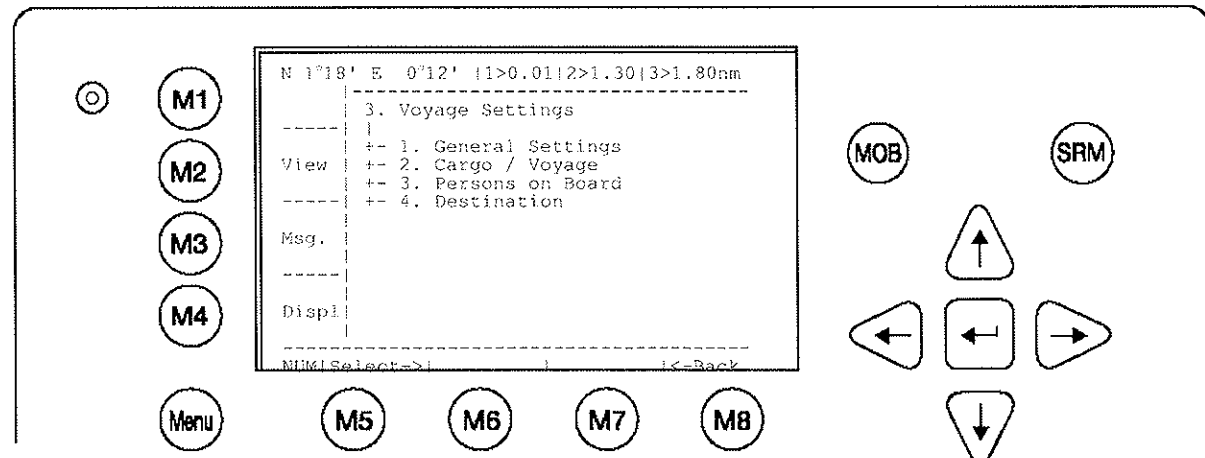
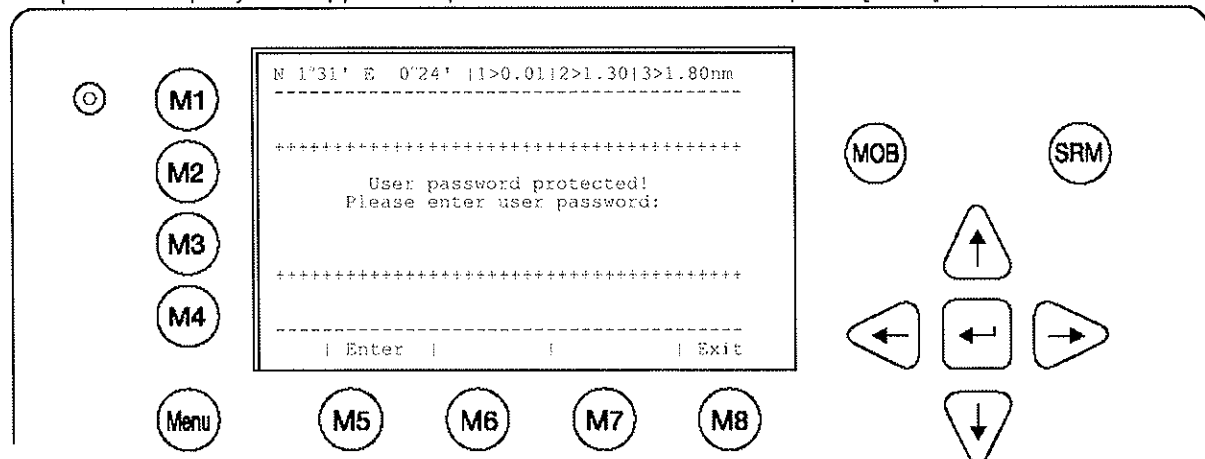

Select Submenu 1 “General Settings” with cursor button [Up] & [Down] by pressing Nr. 1 on the keyboard.

Scroll the Data Fields with [Enter] and input own vessel data. Enter a SOLAS draught in meter (max. = 25.5m), a Inland draught in centimetre (max. = 2000cm) and air-draught value in centimetre (max. = 4000cm) as well as the correct navigational status setting.

Save the new settings by pressing [Save], and return to the Main Menu Screen by pressing [Exit]. Press [Back] to return to the Main Menu without saving any changes.

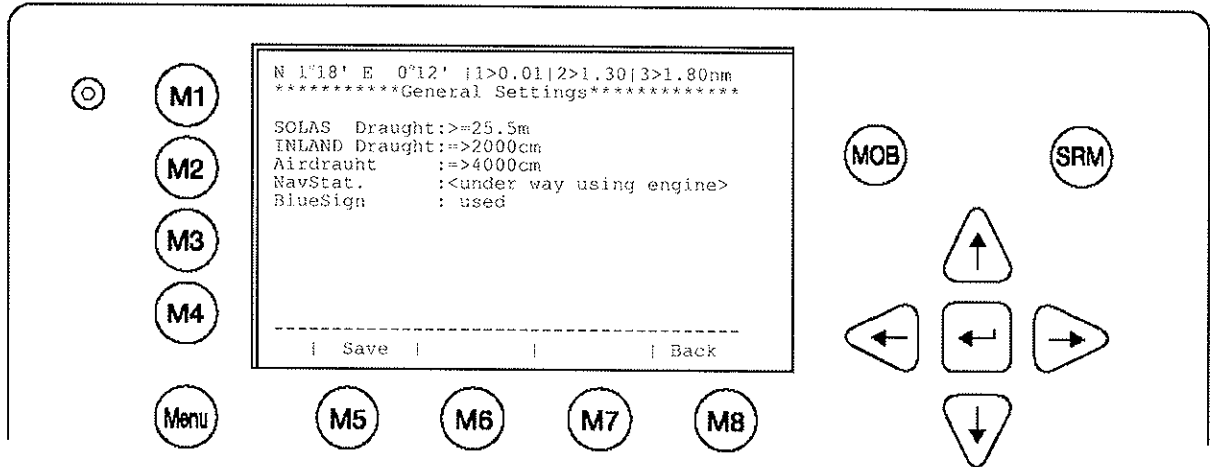

Select Submenu 2 “Cargo/Voyage Settings” with cursor button [Up] & [Down] or by pressing Nr. 2 on the keyboard.

Toggle the values for the ERI ship type, the hazardous cargo (number of blue cones) and the loaded / unloaded status.

Save the new settings by pressing [Save], and return to the Main Menu Screen by pressing [Exit]. Press [Back] to return to the Main Menu without saving any changes.

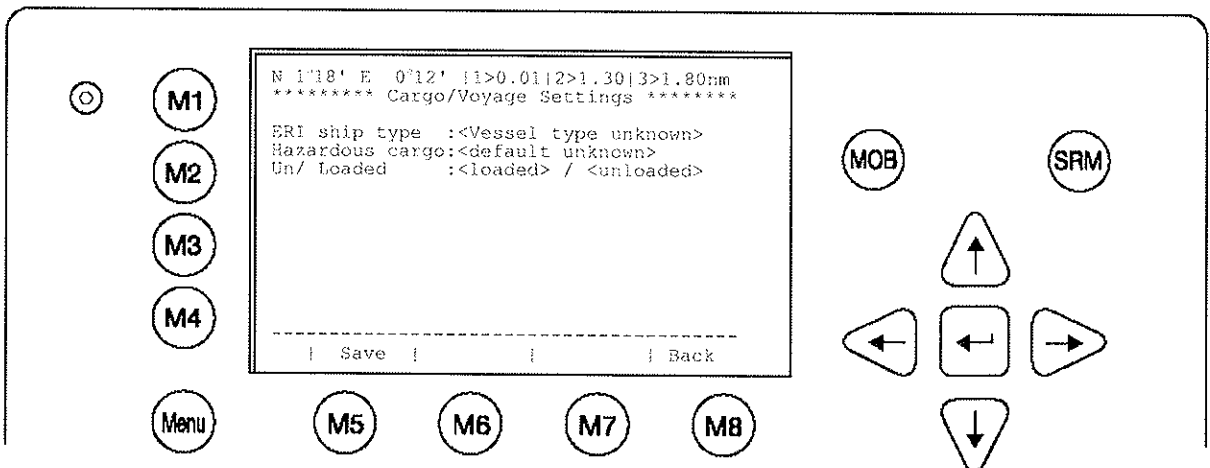

Select Submenu 3 “Persons on Board” with cursor button [Up] & [Down] or by pressing Nr. 2 on the keyboard.

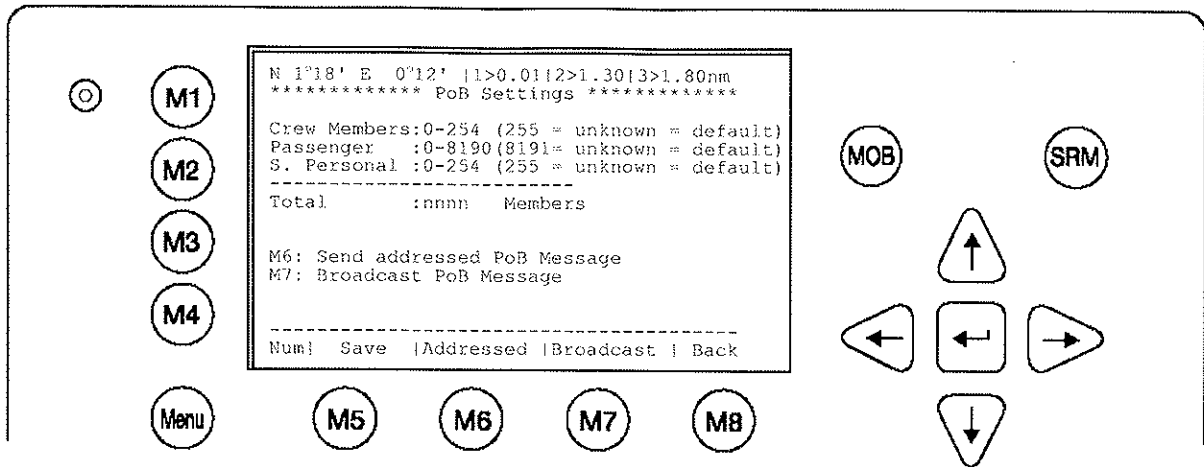

**Note:**

The total number of persons on board will be calculated automatically. In “High Seas” mode this sum will be used for the AIS messages.  
 How to use this menu to transfer PoB – information will be described in detail in the User Manual.

Select Submenu 4 “Destination” with cursor button [Up] & [Down] by pressing Nr. 4 on the keyboard.

Scroll the Data Fields with [Enter] and input the UN destination codes as well as the ETA (estimated time of arrival) data.

Save the new settings by pressing [Save], and return to the Main Menu Screen by pressing [Exit]. Press [Back] to return to the Main Menu without saving any changes.

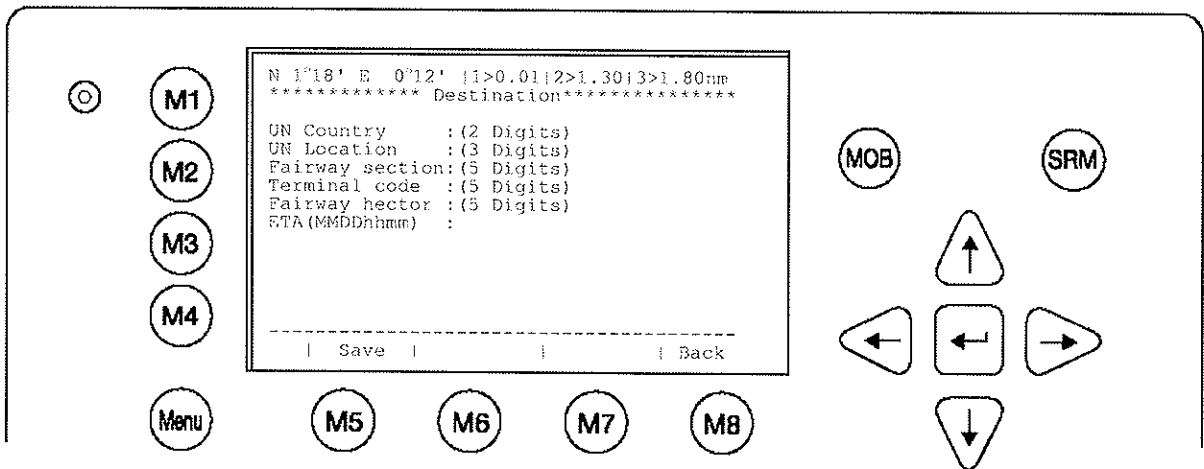

## 4.5 Service and User Passwords

The Transponder system is equipped with two levels of Password Protection, User and Service Password.

1) The User Password, which is the lower security level, allows access to all menus except Menu 6: Service Configuration which is protected by the Service Password.

2) The Service Password is required in order to enter the Service Configuration Menu. This is a higher security level than can not be accessed with the User Password and therefore ensures that the Service Configuration is protected, and limited to authorized service personnel.

The master of the vessel has to ensure that only authorized persons are allowed to make changes to the Service Configuration and ensures that the newly reset password is stored very carefully, as it can not be reset from the default "NAUT" a second time.

**WARNING:** a master key is not available and the unit would have to be returned to a service center to correct for a lost Service password.

The User Password can be reset in the service configuration menu by entering the Service Configuration menu and creating a new password.

### Changing the Service Password

Select "Service Configuration" from the Main Menu with the cursor button [Up] & [Down] or press Number 6 on the keyboard.

The password query field appears. Input default Service Password "NAUT" and press M5 [Enter].

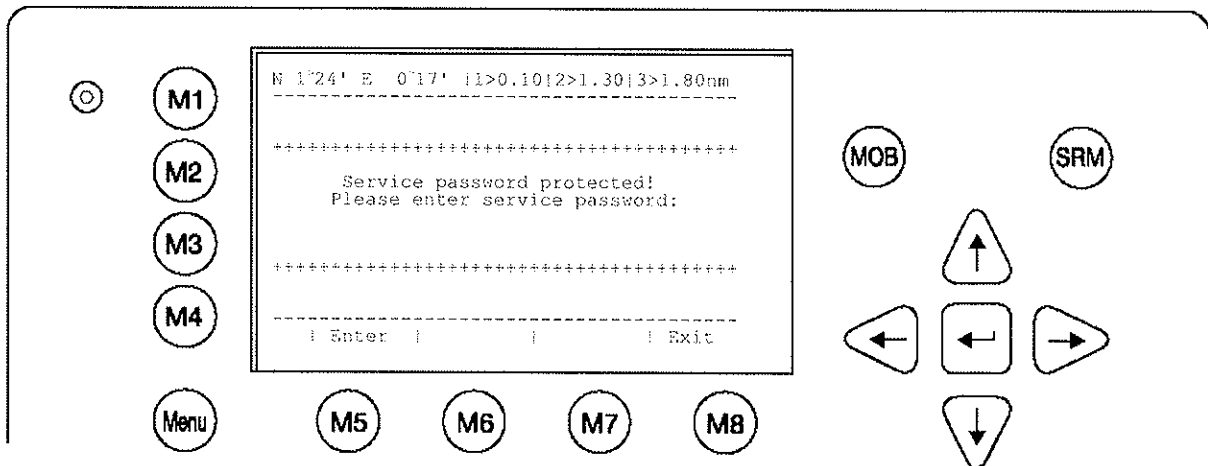

Select Submenu 1 "Change Service Password" with cursor button [Up] & [Down] by pressing Number 1 on the keyboard.

### Service Menu Example:

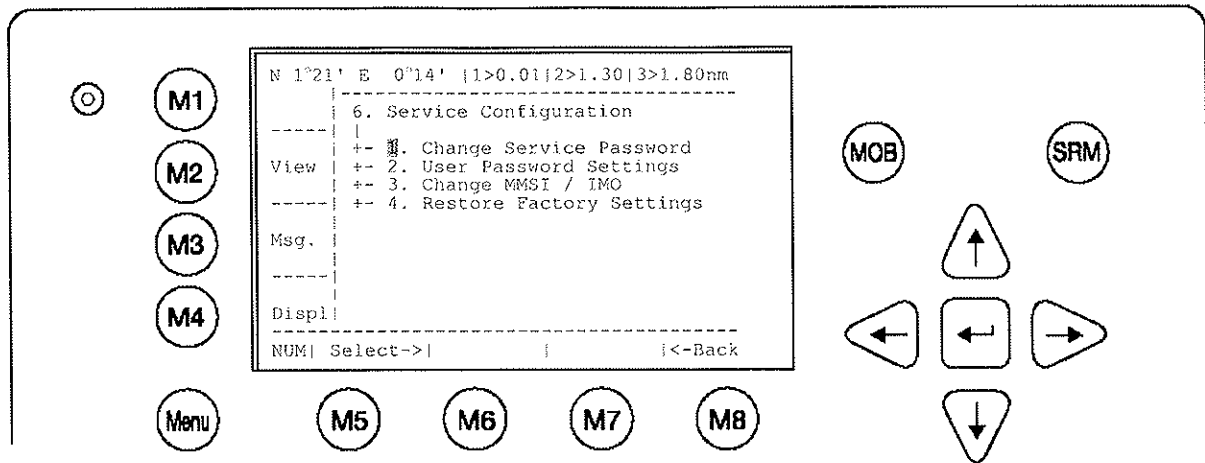

### Service Password Menu Example:

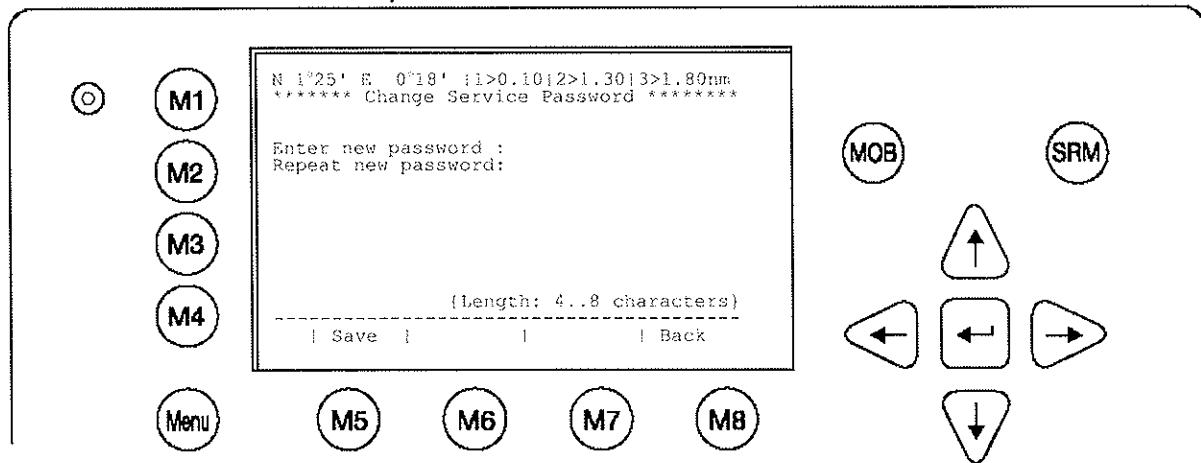

Enter the new Password: Then push Enter (M5).  
Repeat the new Password: Then Push Enter (M5).

A minimum of 4, a maximum of 8 characters are allowed. Should the new password include numbers, use the shift key to generate them.

Press Save to store the change.

### Changing the User Password

Select Submenu 2 "User Password Settings" with cursor button [Up] & [Down] by pressing number 2 on the keyboard.

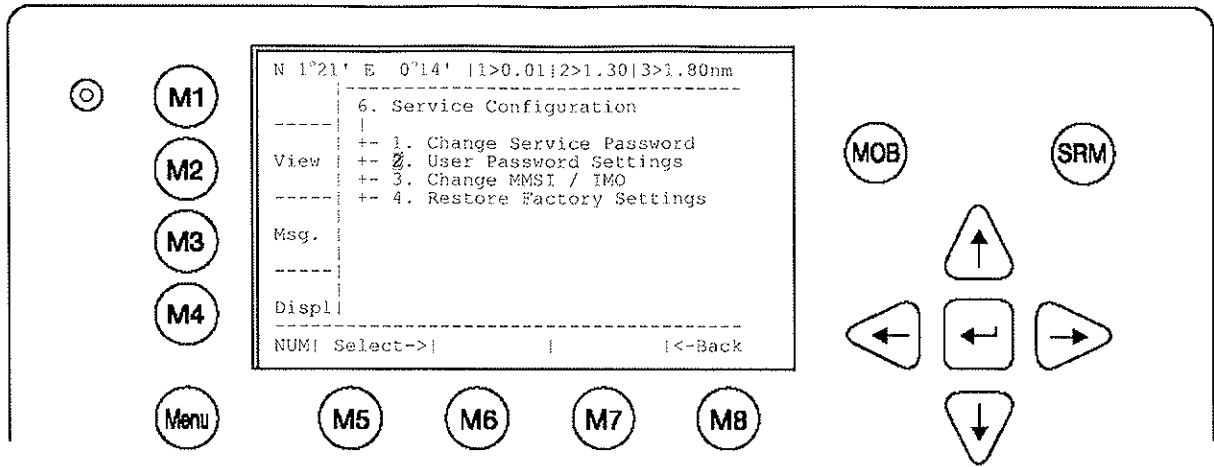

Select Submenu 1 "Change User Password" with cursor button [Up] & [Down] by pressing Number 1 on the keyboard.

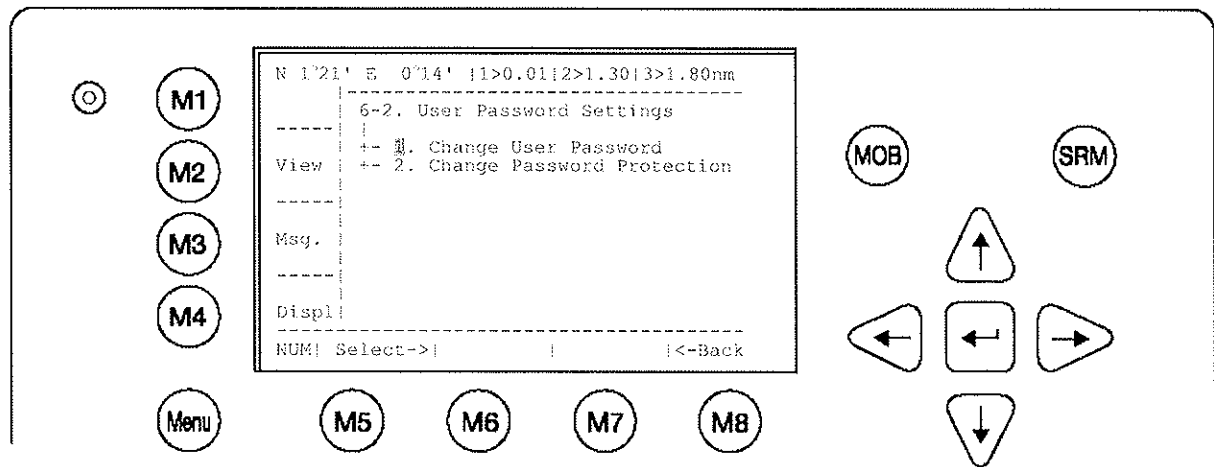

Enter the new Password:  
 Repeat the new Password:  
 A minimum of 4, a maximum of 8 characters are allowed. Should the new password include numbers, use the shift key to generate them.

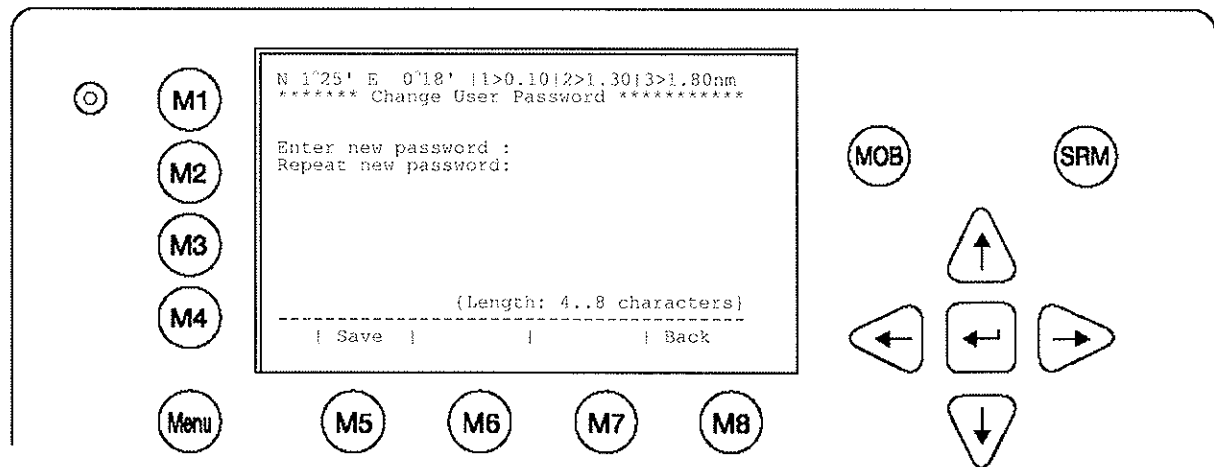

Press Save to store the changes.

## 5 Troubleshooting

### 5.1 Reading and understanding Alarms:

The NAUTICAST differentiates between Alarm and TXT messages. An Alarm informs the user about major system malfunctions and failings in the connected sensors. The Alarm Status informs the user about all active Alarms. The Alarm will be disabled and deleted from the Alarm Status, as soon as the displayed problem has been rectified.

The TXT status displays additional sensor information and the UTC clock status. See tables (Section 5.2 and 5.3) for Alarm and TXT Messages.

Select "AIS Status" with cursor button [Up] & [Down] or press Number 2 on the keyboard.

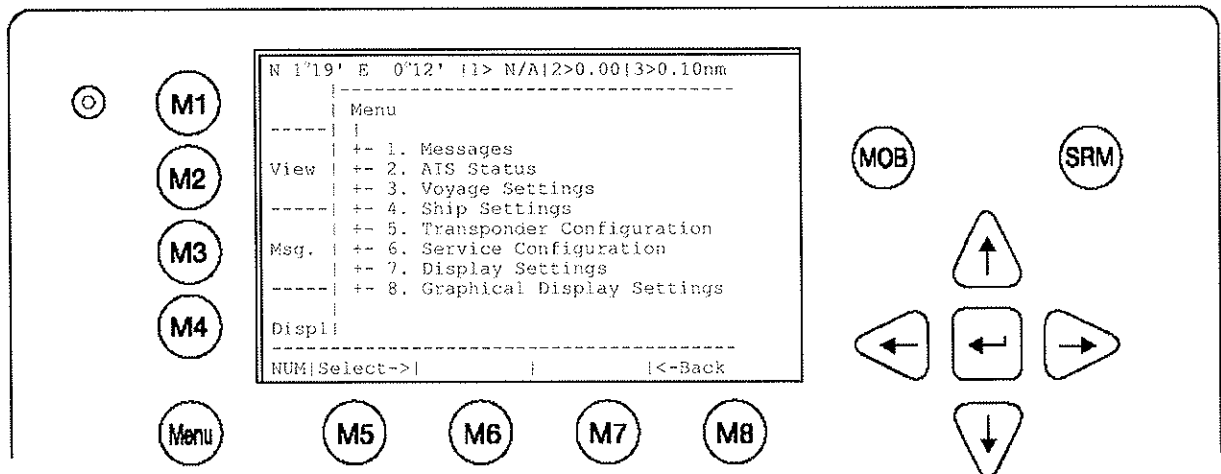

Select "Alarm Status" or "TXT Status" with cursor button [Up] & [Down] or press Number 4 or 5 on the keyboard.

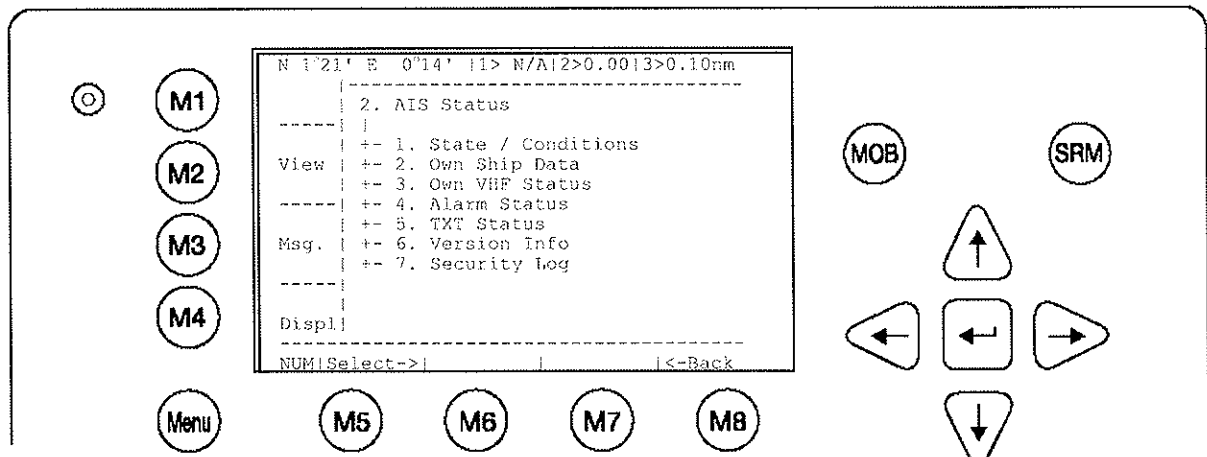



## 5.2 Alarm Codes

ID	Description Text	Cause/Source	System Reaction / Remedy
01	AIS: Tx malfunction	VHF Antenna, cabling	Reaction: The transponder unit stops transmission. If Alarm ID 01 and ID 02 are simultaneously displayed, then a major antenna problem has arisen. Remedy: Check if the antenna is AIS compatible (156-162 MHz) and if the antenna cabling has a short circuit or is missing any contacts at the connectors. If the ID 01 is displayed as a stand alone message, then the unit requires replacing.
02	AIS: Antenna VSWR exceeds limit (VSWR - Voltage Standing Wave Ratio)	VHF antenna, installation	Reaction: The transponder unit continues transmission. Remedy: Check the antenna and the antenna cabling (RG214 / 50 Ohm cable required).
03	AIS: Rx channel 1 malfunction	Internal error	Reaction: The transponder unit stops transmission on the affected channel. Remedy; If this alarm reoccurs regularly, then the transponder unit requires replacing.
04	AIS; Rx channel 2 malfunction		
05	AIS: Rx channel 70 malfunction		
06	AIS: General failure	Internal error	Reaction: The transponder unit stops transmission. Remedy; The transponder unit requires replacing.
25	AIS; External EPFS lost (EPFS = electronic Position Fixing System such as GPS)	No valid data on Ch1, Ch2 or Ch3 is available	Reaction: The transponder unit continues operation using the position data of the internal GPS. If there is no valid position data available from the internal GPS, error 026 is additionally displayed. Remedy: Id 25 indicates that the sentences GLL, GNS, GGA, RMC cannot be received. Check the sensor and the cabling; check if the system that delivers the data is working. Check the baud rate settings of the sensor inputs. AIS requires the protocol NMEA 0183 V3.0!
26	AIS: No sensor position in use	No valid position from internal GPS or external position sensor	Reaction: The transponder unit continues operation. Remedy: Check the sensor cabling and the antenna of the internal GPS sensor.
29	AIS: No valid SOG information	No valid data from external speed sensor or internal GPS	Reaction: The transponder unit continues operation and displays SOG: N/A Remedy: The sentences VBW, VTG, RMC cannot be received. Check the sensor and the cabling; check if the system that delivers the data is working. Check the baud rate settings of the sensor inputs. AIS requires the protocol NMEA 0183 V3.0!
30	AIS: No valid COG Information	No valid data from external sensor or internal GPS	Reaction: The transponder unit continues operation and displays COG: N/A Remedy: The sentences VBW, VTG, RMC cannot be received. Check the sensor and the cabling, check if the system that delivers the data is working. Check the baud rate settings of the sensor inputs. AIS requires the protocol NMEA 0183 V3.0!
32	AIS: Heading lost/invalid	No valid data from external sensor (Gyrocompass)	Reaction: The transponder unit continues operation Remedy: The sentence for HDT cannot be received. Check the sensor and the cabling, check if the system that delivers the data is working. Check the baud rate settings of the sensor inputs. AIS accepts true heading only (no magnetic).
35	AIS: No valid ROT Information	No ROT indicator is used. No valid data from external sensor	Reaction: The transponder unit continues operation Remedy: The sentence for ROT cannot be received. If a Rate Of Turn indicator is not in use, then it suffices to just acknowledge the alarm. The Alarm Status will store the information that no ROT sensor is available. Otherwise, check the sensor and the cabling. Check if the system that delivers the data is working. Check the baud rate settings of the sensor inputs. The AIS requires the protocol NMEA 0183 V3.0!

53	AIS: BATTERY SOON LOW	Battery is soon out of capacity	Reaction: Own ship data is lost after powering on/off the system. Remedy: consider to contact Technical Support for additional help
55	AIS: PRESS ENTER TO EXIT 1W/AUTO TX MODE	Conditions for enabling 1 Watt TX power are not valid	Reaction: Conditions for enabling 1 Watt TX power are not valid. This means that: <ul style="list-style-type: none"> <li>• the speed is &gt;3kn and / or</li> <li>• the navigational status is NOT moored / at anchor and / or</li> <li>• the ship type is NOT "Tanker"</li> </ul> Remedy: <ul style="list-style-type: none"> <li>• Check the conditions (SOG, Navstat, Shiptype)</li> <li>• if GPS is valid ( a invalid GPS causes also this alarm)</li> </ul>
56	AIS: ENTER MMSI NUMBER	No valid MMSI entered.	Reaction: During the initial boot or after "factory settings" the user is asked to enter a valid MMSI. As long as this is not done, the system does not transmit. Remedy: Enter a valid MMSI

### 5.3 Text Messages

ID	Description Text	Cause/Source	Reaction of the System / Remedy
07	AIS: UTC clock lost	Internal GPS	Reaction: the transponder unit continues operation using indirect or semaphore synchronisation Remedy: Check GPS Antenna for AIS.
21	AIS: external DGNSS in use	Information	Reaction: Positioning is fully operational Remedy: no action required
22	AIS: external GNSS in use	Information	Reaction: The transponder unit continues operation using the position data from a GNSS receiver Remedy: no action required
23	AIS: internal DGNSS in use (beacon) 023	Information	Reaction: The transponder unit uses position data from the internal source. The internal GNSS receiver is capable of processing DGNSS corrections. Remedy: no action required
24	AIS: internal DGNSS in use (message 17)		
25	AIS: internal GNSS in use	Information additional to Alarm ID 25	Reaction: The transponder unit continues operation using the position data from the internal GPS. Remedy: Check the sensor and the cabling; Check if the system that delivers the data is working; Check the baud rate settings of the sensor input
27	AIS: external SOG/COG in use	Information	Reaction: COG/SOG is in full operation Remedy: no action required
28	AIS: internal SOG/COG in use	Information additional to Alarm ID 29 or ID 30	Reaction: The transponder unit continues operation using the data from the internal GPS. Remedy: Check the sensor and the cabling; Check if the system that delivers the data is working; Check the baud rate settings of the sensor inputs
31	AIS: Heading valid	Information	Reaction: Heading is in full operation Remedy: no action required
33	AIS: Rate of Turn Indicator in use	Information	Reaction: A Rate Of Turn indicator is connected and in full operation Remedy: no action required
34	AIS: Other ROT source in use	Information	Reaction: The transponder unit is operating with ROT data rather than with TIROT data - therefore the AIS only differs between + 127 (turning right at 720 degrees per minute or higher) and - 127 (turning left at 720 degrees per minute or higher)

### 5.4 Restarting the NAUTICAST

The NAUTICAST could be restarted during operation by pressing the keys "Shift" + "Fn" + "Del" simultaneously. It could take up to 6 minutes to receive all information from other ships again because of their reporting interval.

## 6 Accessories

The following material is included with the NAUTICAST.

<b>NAUTICAST Inland AIS Kit</b>	1 NAUTICAST Inland AIS Transponder 1 installation manual, 1 user Manual 3 caps of plug 1 cable clamp (M5 thread) 1 guide plate Kit 3 angles + 3 mounting screws (screw bolt + square nut)
includes	

The NAUTICAST Inland AIS is supplied with some of the components listed below (contents depend on customer requirements).

<b>Category</b>	<b>Description</b>	<b>Order Number</b> (old "NAU" numbers in brackets)
<b>Mountings:</b>	Gimbal Style Mounting Kit + 2 wing bolts + 4 screws	2650 (NAU-D503)
	Mounting kit retro fit-frame + 3 screws, 3 clips, 3 nuts	2651 (NAU-D500)
	19" frame + 3 mounting screws (screw bolt + square nut)	Discontinued
<b>GPS antenna solutions:</b>	Matsushita GPS antenna marine II	2625 (NAU-X6011)
	Deck Mounting for GPS Antenna Marine II (plastic) - Glomex (For P/N 2625)	2627 (NAU-X6012)
	Pipe Mounting for GPS-antenna Marine II metal (For P/N 2625 GPS)	2626 (NAU-X6013)
	Deck Mounting for GPS Antenna Marine II (metal) (For P/N 2625 GPS)	2821 (NAU-X6014)
	Procom GPS antenna GPS 4	2622 (NAU-B602)
	Deck Mounting Kit Metal Horiz. Surface -ProCom (for P/N 2622 and 2623) (Thread 1/12)	2623 (NAU-X6022)
<b>VHF antenna solutions:</b>	VH-3200 VHF Stainless Steel Whip Antenna 91.4cm (36 in.) includes Mounting Kit & Plug PL Male for RG214	2628 (NAU-B614)
	Comrod VHF antenna AV 7 + mounting kit	2621 (NAU-B611)
<b>Single antenna solutions :</b>	Comrod AC 17 - AIS (combined GPS/VHF antenna) + mounting kit + splitter and cable	2624 (NAU-B620)
<b>Cables and Interfaces</b>	GPS/VHF Interface Cable, 10 meters ( 32.8ft) Includes 1 each Male PL & TNC connector installed.	2613 (NAU-B550)
	GPS / VHF extender with N and TNC connection (1m) + 1 pcs N(m)/RG214 crimp + 2 pcs TNC(m)/RG214 crimp + 1 pcs. PL(m)/RG214 crimp	2612 (NAU-B554)
	AIS connection box	2640 (NAU-B401)
	AIS cable open (3m) with all interfaces + pilot plug	2610 (NAU-B503)
	AIS Workboat/Inland Cable (power & ECDIS) 1.5 meters (4.5 ft) RS422	2614 (NAU-B508)
	AIS Blue Sign cable (including RS232 ECDIS) 1,5m	2635 (NAU-B502)
	Connector N(m)/RG214 crimp	2631 (NAU-X5531)
	Connector PL(m)/RG214 crimp	2632 (NAU-X5533)
	Connector TNC(m)/RG214 crimp	2633 (NAU-X5534)

## 7 Technical Information

PHYSICAL		SPECIFIED STANDARDS	
Size in mm / inch (w)	281,26mm / 11,07inch	IMO MSC.74(69) Annex 3	
Size in mm / inch (h)	60mm / 2,36inch	ITU-R M.1371 (Class A)	
Size in mm / inch (d)	201,26mm / 7,92inch	IALA Techn.Clar. of ITU-R M.1371-1 (Ed.1.3)	
Weight	2490g / 5,50pound	IEC 61993-2 (2002)	
Operating Temperature	-15°C to +55°C / 5°F to 131°F	IEC 61162-1 (2000)	NMEA 0183-3
		IEC 61162-2 (1998)	NMEA 0183-3
		IEC 61162-3	NMEA 2000
POWER SUPPLY			
Supply Voltage (galvanic isolated)	24 V DC (-10% +30%)	ITU-R M.823-2	
Input Current	min.7 A (24V)	IEC 61108-1 (1996)	
		IEC 60 945 (1996)	
INTERFACES			
Number of Data Ports	3 Input / 4 I-O / 1 Output	ITU-R M.825-3	
IEC 61162-1/2	(RS422 / NMEA 0183)	ITU-R M.1084-3	
ITU-R M.823-2	(RS422 / RTCM SC104)		
Bitrate		VHF	
CH1 Sensor Input; (i.E.: GPS)	4800 bps or 38400 bps	Frequency Range	156 MHz - 162MHz
CH2 Sensor Input; (i.E.: GYRO)	4800 bps or 38400 bps	Channel Spacing	12,5 or 25kHz
CH3 Sensor Input; (i.E.: HDG)	4800 bps or 38400 bps	Number of RF Channels	3 Receiv. / 1 Transm.
CH4 ECDIS Port (In- / Output) AIS targets, AIS messages	in/ out 38400 bps	Number of AIS Receivers	2
CH5 Pilot Port (In- / Output) AIS targets, AIS messages	in/out 38400 bps	Number of DSC Receivers	1
CH8 Long Range Port (In- / Output)	in/out 38400 bps	Frequency Error	+/- 2.5ppm
CH9 DGPS correction (In- / Output) (RTCM SC104)	in/out 9600 bps	VHF TRANSMITTER	
Alarm Circuit CH10	Dry relay contact (see BIIT – Alarm System)	Output Power	2 Watt to 12.5 Watt (adjustable)
		Receive to Transmit Switching Time	< 1ms
		Transmit release time	< 1ms
		Automatic shutdown	1 sec.
		Channel switching time	< 25ms
		Attack Time	< 1ms
BUILT IN GPS		VHF RECEIVER	
Receiver Architecture	12 channel differential	Max. Useable Sensitivity	< -110dBm
Tracking Capability	12 satellites sim.	Co-channel Rejection	> -8dB (25kHz); > -12dBm (12.5kHz)
Accuracy Horizontal	10m / 2drms *	Adjacent Channel Selectivity	> 70dB (25kHz); > 60dB (12.5kHz)
Accuracy Vertical	15m / 2drms *	Inter-modulation Rejection	> 65dB
GPS Antenna Connector	TNC	Spurious Response Rejection	> 70dB
DGPS Accuracy	< 5m / 2drms	Blocking	> 84dB
*) depends on SA		VHF MODEM	
GPS Solutions		Bitrate GMSK	9600 bps
VHF interop. (DGPS over Msg.17)		RF Baud Rate (DSC)	1200bps
Beacon interoperability		Modulation	GMSK / FSK
Combined GPS/VHF Antenna		SOFTWARE	
		NAUTICAST INLAND AIS Version 2.0.x	
		- installed and ready for use	
		- implemented configuration Software	
		- User friendly Interface	
		to System and AIS Information	
		- additional Interface to System Configuration (Windows 2000 <sup>®</sup> )	
		- NAUTICAST Demonstrator for training purposes (Windows 2000 Windows XP <sup>®</sup> )	
		HARDWARE	
		NAUTICAST Version 1.0.x	
		DISPLAY	
		Integrated	Text 40x16 chars graphical 240 x 128 adjustable brightness and contrast
OPTIONAL INTERFACES			
Number of Data Ports RS232	up to 5		
Bitrate	Up to 115000 bps		
Simplex / Duplex	Duplex		
Number of Data Ports IEC 61162-3 CAN (RS485)	1		
Bitrate	up to 1 Mbps		
KEYBOARD			
Integrated	alphanumeric		

## **8 Contact and Support Information**

Contact your local dealer for NAUTICAST support.  
Please see our ACR Website for Service Listing.

**ACR Electronics Europe GmbH**  
**Mariahilfer Straße 50/2/11**  
**A-1070 Vienna, Austria**  
Tel: +43 (1) 5 237 237 - 0  
Fax: +43 (1) 5 237 237 - 150  
Email: [Technical.Support@acr-europe.com](mailto:Technical.Support@acr-europe.com)  
Web: [www.acr-europe.com](http://www.acr-europe.com)

**ACR Electronics**  
**Customer Service**  
**5757 Ravenswood Road**  
**Fort Lauderdale, FL 33312, U.S.A.**  
Tel.: +1 (954) 981-3333  
Fax: +1 (954) 983-5087  
Email: [info@acrelectronics.com](mailto:info@acrelectronics.com)  
Web: [www.acrelectronics.com](http://www.acrelectronics.com)

## 9 Appendix

### 9.1 Samples for battery calculation

#### 9.1.1 Typical Installation

GMDSS Battery size calculation for 1 hour (Battery size calculation based on the IMO regulations Chapter IV - Reg.13)

Ship Name QMIII  
 Battery capacity 230Ah  
 Battery Type 2x (12V / 135)  
 Area A1, A2, A3  
 Battery located in battery chest on observation deck

Pos	Qty.	Equipment	I <sub>max</sub> (A)	I <sub>standby</sub> (A)	Total (A) (I <sub>max</sub> /2 + I <sub>standby</sub> ) * Qty.)
1	1	Skanti TRP 8751D Radiotelephone	45,00	3,00	25,50
2	1	Debeg 3818 DSC Controller		0,21	0,21
3	2	T&T 3020 Inmarsat-C Transceiver	3,20	0,40	4,00
4	2	Inmarsat-C Monitor		0,85	1,70
5	2	Inmarsat-C Printer	1,00	0,20	1,40
6	1	CI 8501 Navtex Receiver		0,50	0,50
7	2	Skanti USE 300 VHF Radiotel.	2,80	0,05	2,90
8	2	Debeg 3817 VHF DSC Controller		0,21	0,42
9	1	Sailor RT2047 VHF Radio Tel.	6,50	1,00	4,25
10	1	Simrad GN 33 GPS		0,63	0,63
11	1	Koden KGP 900 GPS	4,00	0,63	2,63
12	1	Koden LR 771 Loran C		0,42	
13	1	Emergency light		2,00	2,00
14	1	AIS Nauticast	7,00	0,75	0,84
				Total	46,98

$K1_{\text{partly discharged battery}} = \text{Total consumption} \times 1,25 = 58,73 \text{ Ah}$

$K1_{-30^\circ} = K1 \times 1 / 0,30 = 106,78 \text{ Ah}$

$K5 = K1_{-30^\circ} / 0,65 = 164,28 \text{ Ah}$

**Selected Battery (K5) = 230,00 Ah**

$K1_{\text{partly discharged battery}} =$

correction factor taking care that the battery might not be fully charged  
 (we assume that in worst case the battery is only at 80% fully charged)

$K1_{-30^\circ} =$

correction factor taking care that the battery may be used  
 at ambient temperature of - 30 degrees  
 (at -30 degrees the battery has only 30% of nominal capacity)

$K5 =$  correction factor taking care of that the battery  
 is defined by manufacturer for 5 hours discharge time

Calculation for AIS =

transmit pulse length 26,6ms with a maximum repetition rate of 2 seconds results in a maximum of 30 pulses/minute → 1800 pulses/hour x 26,6 ms → 47880 ms → 47,88 seconds transmit time during one hour 47,88 seconds → 0,8 minutes → 0,0133 hours transmitting time during one hour operation  
 → Up-Rounded to 0,02 hrs transmitting time

Above mentioned calculation assumes that all equipment is in operation which is normally not valid, that means that the actual consumption is lower.

### 9.1.2 RM GMDSS Compact-Console Area A3 with 250 W MF/HF

GMDSS Reserve Battery Calculation ( 24 V DC ) for Raytheon Marine GmbH GMDSS Compact-Console Area A3 with 250 W MF/HF

According to IMO Regulation COMSAR/Circ.16 4. March 1998

**A:** with Emergency Generator (SOLAS IV 13.2 )

The GMDSS equipment shall be able to operate one (1) hour on reserve power with 50% of time in transmission mode and 50% in receiving mode.

**B:** without Emergency Generator (SOLAS IV 13.2 )

The GMDSS equipment shall be able to operate six (6) hours on reserve power with 50% of time in transmission mode and 50 % of receiving mode.

Equipment	Type	Transmitting	Receiving	Additional
MF/HF	STR 2000 R	15 A	4 A incl.DSC	
Inmarsat C	STR 1500 CN	5 A	1,8 A incl.EGC	
VHF 1 with DSC	VHF1000DSC	6,5 A	0,65 A incl.DSC	
VHF 2 with DSC	VHF1000DSC	6,5 A	0,65 A incl.DSC	
AIS	RM 808 AIS	5,0 A	1,0 A	
Emergency Light				2,5 A
<b>Total</b>		<b>38 A</b>	<b>8,1 A</b>	<b>2.5 A</b>

#### Calculation:

##### Case A:

$1h \times (0.5 I_{TX} + I_{RX} + I_{Add}) \times 1.4 = 41.44 \text{ Ah}$

**recommend battery capacity is 86 Ah**

##### Charger:

$I_{Charg} \times 0.1 I_{Batt/h} = 8.6 \text{ A}$

**recommend charger is type 20 A**

##### Case B:

$6h \times (0.5 I_{TX} + I_{RX} + I_{Add}) \times 1.4 = 248.66 \text{ Ah}$

**The battery calculation should not be used for uninterruptible power supply (UPS) configuration.**

### 9.1.3 RM GMDSS Compact-Console Area A3 with 400 W MF/HF

GMDSS Reserve Battery Calculation (24 V DC) for Raytheon Marine GmbH GMDSS Compact-Console Area A3 with 400 W MF/HF

According to IMO Regulation COMSAR/Circ.16 4. March 1998

**A:** with Emergency Generator ( SOLAS IV 13.2 )

The GMDSS equipment shall be able to operate one (1) hour on reserve power With 50% of time in transmission mode and 50% in receiving mode.

**B:** without Emergency Generator ( SOLAS IV 13.2 )

**The GMDSS equipment shall be able to operate six (6) hours on reserve power with 50% of time in transmission mode and 50 % of receiving mode.**

Equipment	Type	Transmitting	Receiving	Additional
MF/HF	STR 2000	18.75 A	4 A incl.DSC	
Inmarsat C	STR 1500 CN	5 A	1,8 A incl.EGC	
VHF 1 with DSC	VHF1000DSC	6.5 A	0,65 A incl.DSC	
VHF 2 with DSC	VHF1000DSC	6.5 A	0,65 A incl.DSC	
AIS	RM 808 AIS	5.0 A	1,0A	
Emergency Light				2,5 A
<b>Total</b>		<b>41.75 A</b>	<b>8,1 A</b>	<b>2.5 A</b>

#### Calculation:

**Case A:**

$$1\text{h} \times ( 0.5 I_{TX} + I_{RX} + I_{Add} ) \times 1.4 = 44.06 \text{ Ah}$$

**recommend battery capacity is 86 Ah**

**Charger:**

$$I_{Charg} \times 0.1 I_{Batt/h} = 8.6 \text{ A}$$

**recommend charger is type 20 A**

**Case B:**

$$6\text{h} \times ( 0.5 I_{TX} + I_{RX} + I_{Add} ) \times 1.4 = 264.39 \text{ Ah}$$

The battery calculation should not be used for uninterruptible power supply (UPS) configuration

## **9.2 Drawings and Approvals**

These documents are included on the following pages:

- (1) Dimensional Drawings**
- (2) Type Approvals**
- (3) Connection Drawings**
- (4) Antenna Layout**



# Technische Daten / Specification :

Spannungsversorgung / power supply: 24V DC  
 Strom / current: 5A  
 Betriebstemperaturbereich / operation temperature: -15°C to +55°C  
 Schutzart / type of enclosure: IP65 n. EN60529  
 magnetischer Schutzabstand / magnetic safety distance: 0,3m  
 Gewicht / weight: 2400g (ohne Kabel / without cable)  
 Farbe / color: RAL7021

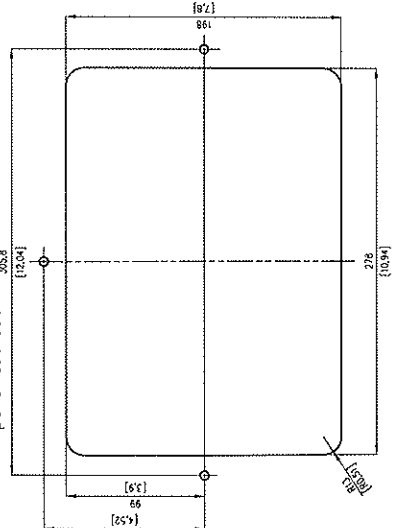
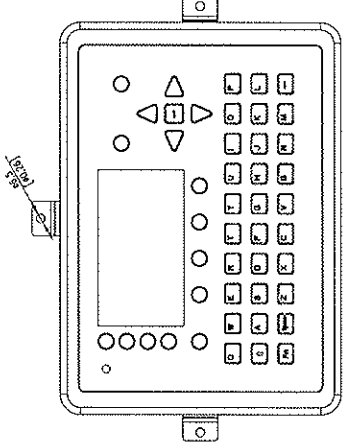
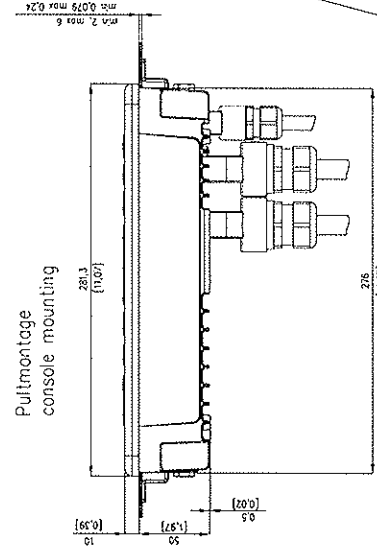
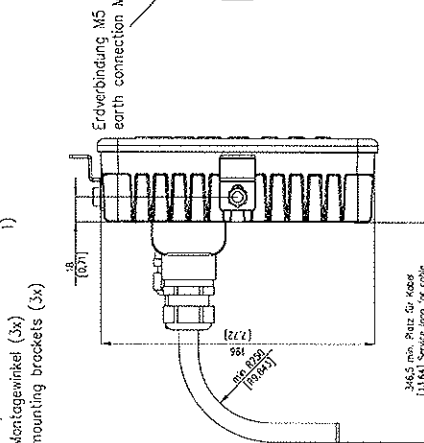
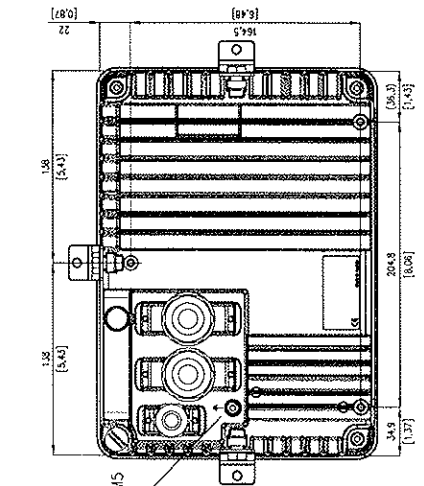
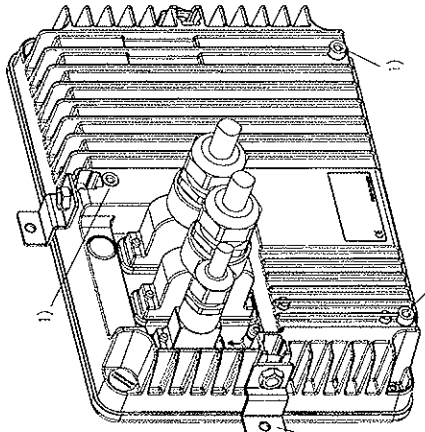

1) Befestigungspunkte 3x, Gewindesackloch M5 5tief  
 fixing points 3x, blind hole thread M5 depth 5

DISTANCE FROM MAGNETIC COMPASS  
 STANDARD TYPE: 0,3m  
 STEERING TYPE: 0,3m

CAD	SCALE	WEIGHT:	2,4 Kg
DRAWING TITLE DIMENSIONAL DRAWING FOR X-Back DS			
DRAWING NO. NAU-A021DWG			
DATE 20.05.03			SH 1
REVISIONS			OF 2

Ic-Nr.:2600662

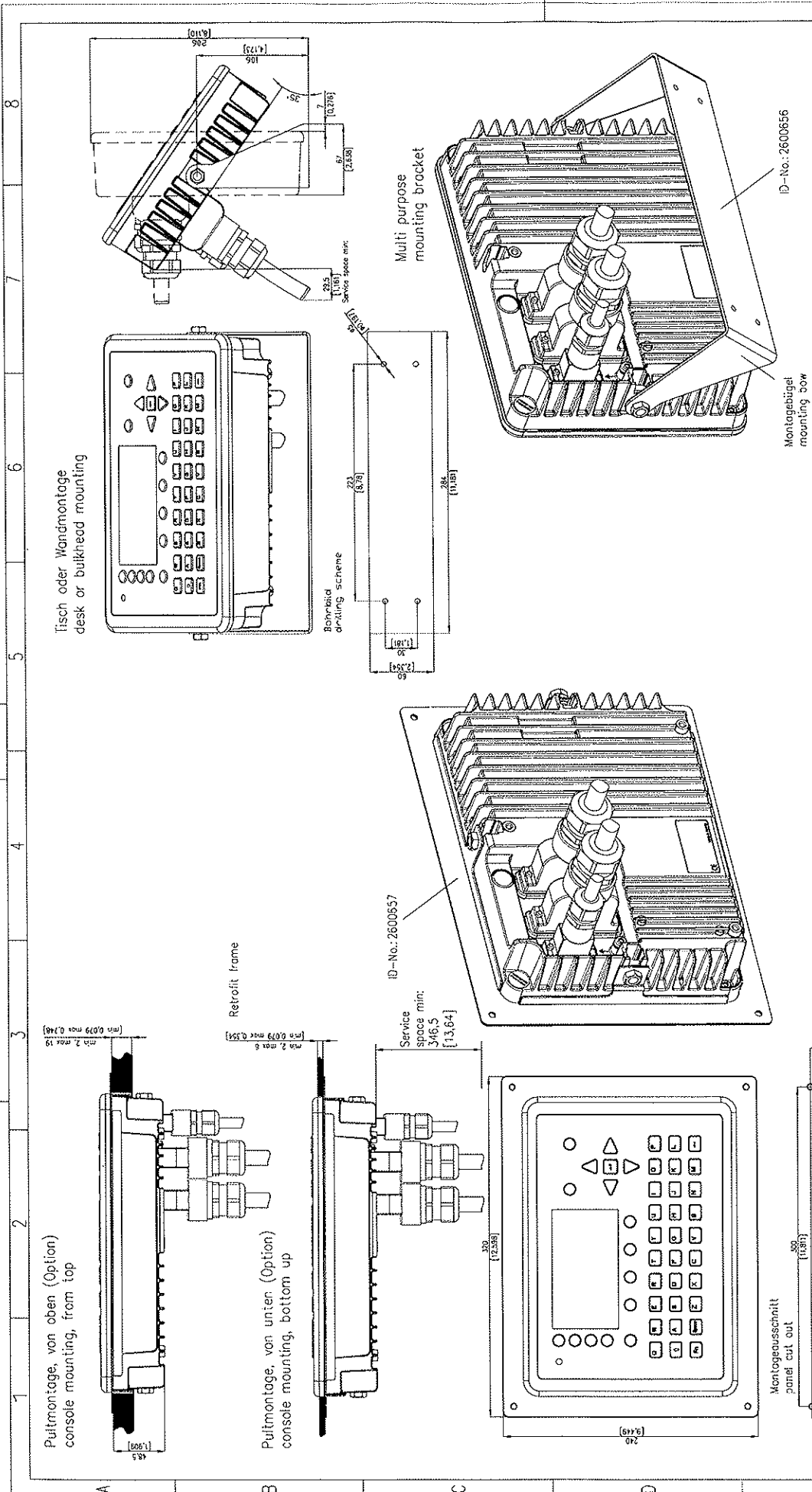

SCALE		WEIGHT: 2,6 Kg	
DRAWING TITLE DIMENSIONAL DRAWING FOR X-Back DS, optional mounting kits			
DRAWING NO. NAU-A021DWG		SH: 2 OF: 2	
DISTANCE FROM MAGNETIC COMPASS STEERING TYPE: 0,3m		mm [INCH]	
STANDARD TYPE: 0,3m		DATE 29.04.2003	
LTR		REVISIONS	
1		20.05.03	
DATE		DATE	
20.05.03		20.05.03	
ACCEPTED		ACCEPTED	
AL 20.05.2003		AL 20.05.2003	
<b>NAUTICAST</b>			

Stromlaufplan  
circuit diagram

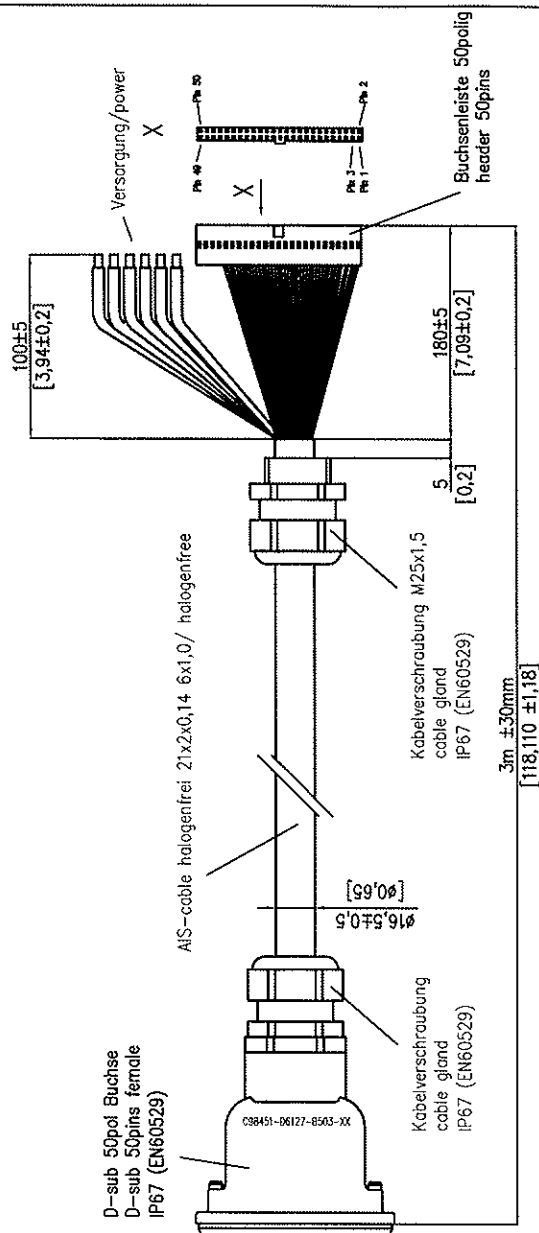
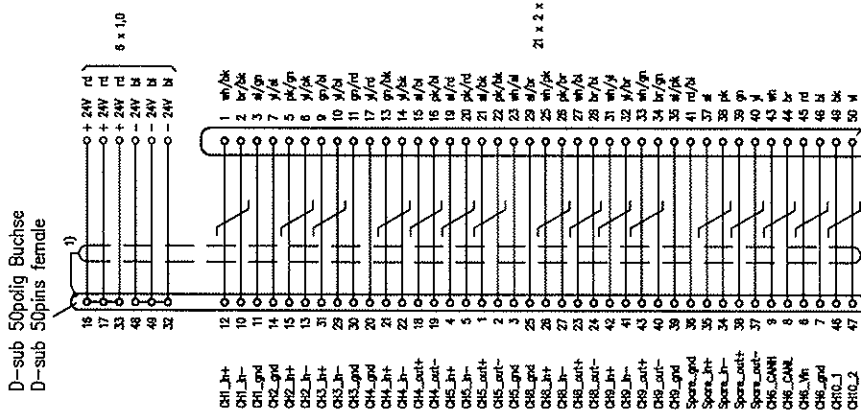

DISTANCE FROM MAGNETIC COMPASS		SCALE	
STANDARD TYPE: ...m	STEERING TYPE:	-	WEIGHT: 1,4 Kg
DRAWING TITLE		DRAWING NO.	
DIMENSIONAL DRAWING FOR		NAU-B503DWG	
AIS cable connection box 3m [118,110]		SH 1	
ACCEPTED AL 29.04.2003		OF 1	
DATE	DR	DATE	DP
29.04.2003		29.04.2003	
REVISIONS		DATE	
1		20.06.03	

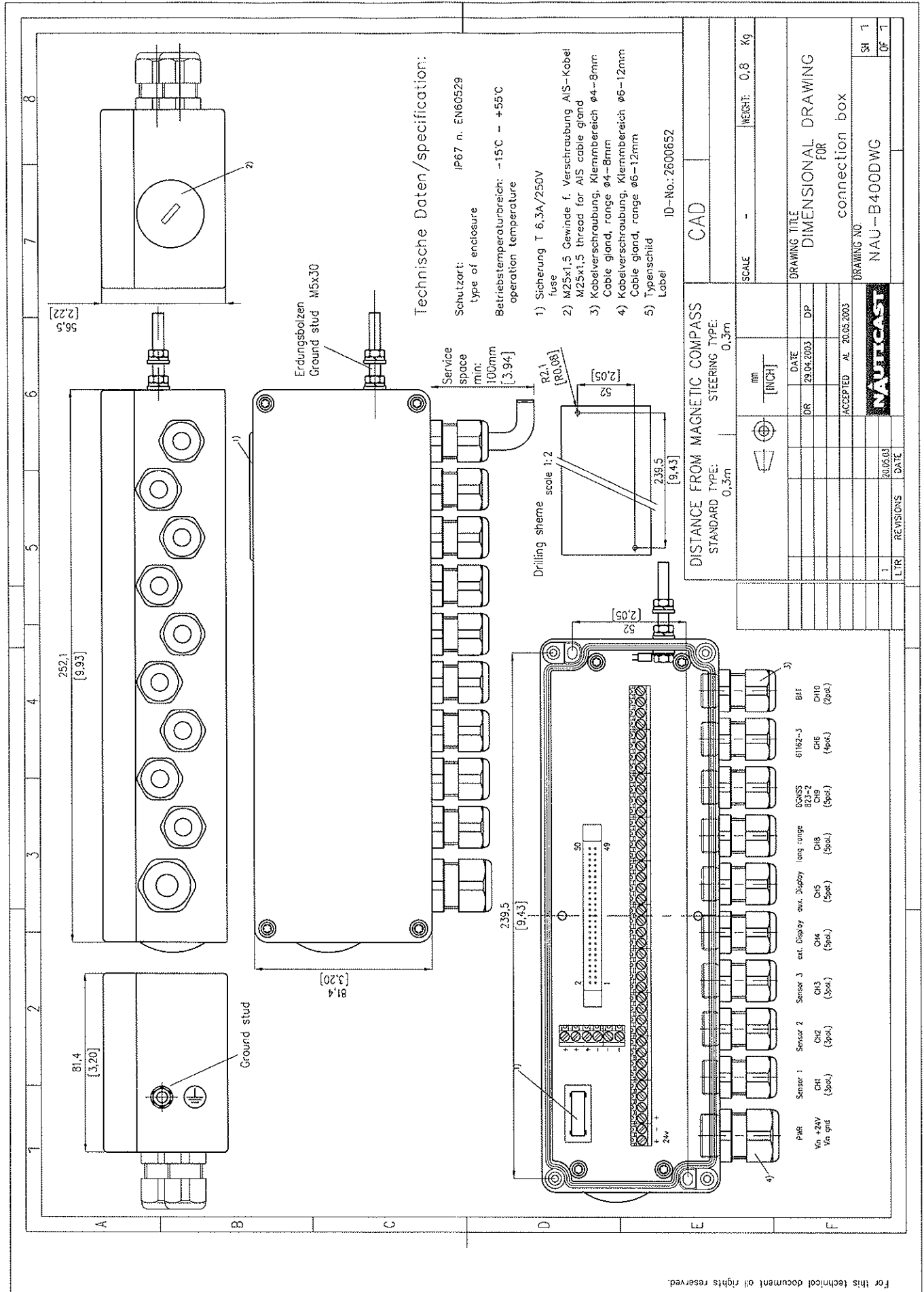

Technische Daten/specification:

Schutzart: IP67 n. EN60529  
 type of enclosure  
 Betriebstemperaturbereich: -15°C - +55°C  
 operation temperature

- 1) Sicherung T 6,3A/250V fuse
- 2) M25x1,5 Gewinde f. Verschraubung AIS-Kabel M25x1,5 thread for AIS cable gland
- 3) Kabelverschraubung, Klemmbereich ø4-8mm Cable gland, range ø4-8mm
- 4) Kabelverschraubung, Klemmbereich ø6-12mm Cable gland, range ø6-12mm
- 5) Typenschild Label

DISTANCE FROM MAGNETIC COMPASS STANDARD TYPE: 0,3m		SCALE: -		WEIGHT: 0,8 Kg	
STEERING TYPE: 0,3m		ID-No.: 2600652		CAD	
DATE: 20.04.2003		DRAWING TITLE: DIMENSIONAL DRAWING FOR connection box		DRAWING NO: SH 1 OF 1	
DR: DP		ACCEPTED AL: 20.05.2003		DRAWING NO: SH 1 OF 1	
LTR REVISIONS		DATE: 20.05.03		NAUTICAST	

PMR	Sensor 1	CH1	(3pc.)	Sensor 2	CH2	(3pc.)	Sensor 3	CH3	(3pc.)	ext. Display	CH4	(5pc.)	Display	CH5	(5pc.)	long range	CH6	(5pc.)	BOSS	CH7	(5pc.)	61162-3	CH8	(4pc.)	Bit	CH10	(2pc.)
V <sub>in</sub> +23V																											
V <sub>in</sub> gnd																											

1 2 3 4 5 6 7 8

A B C D E F

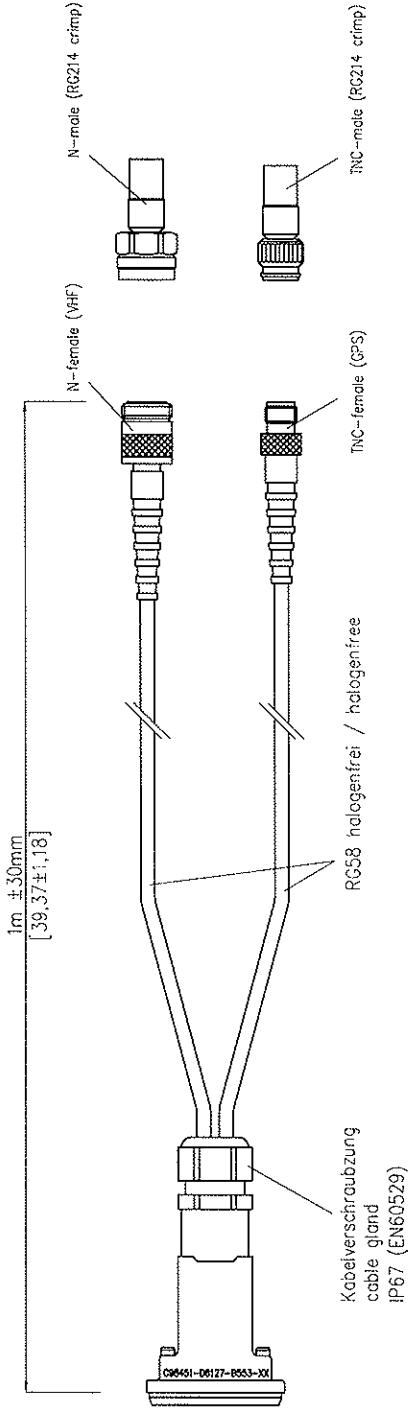

Stromlaufplan  
circuit diagram

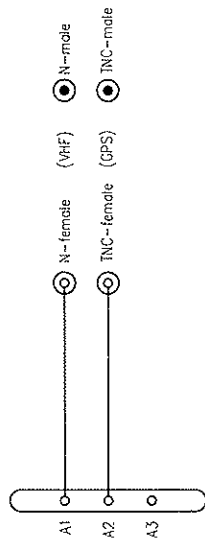

Id-No.: 2600653

DISTANCE FROM MAGNETIC COMPASS  
STEERING TYPE: ...m

CAD

SCALE	-	WEIGHT	0,2	Kg
DRAWING TITLE	Mößzeichnung / DIMENSIONAL DRAWING FOR GPS/VHF cable for extension N TNC			
DATE	29.04.2003	DP		
DR				
ACCEPTED	AL	20.05.2003		
<b>NAUTICAST</b>				
LTR	1	REVISIONS	20.05.03	DATE
SH: 1 OF 1				

NAU-B553DWG

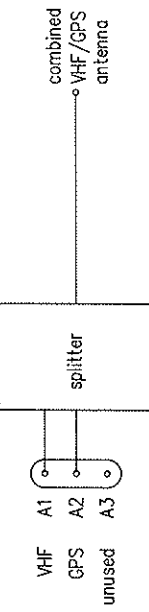
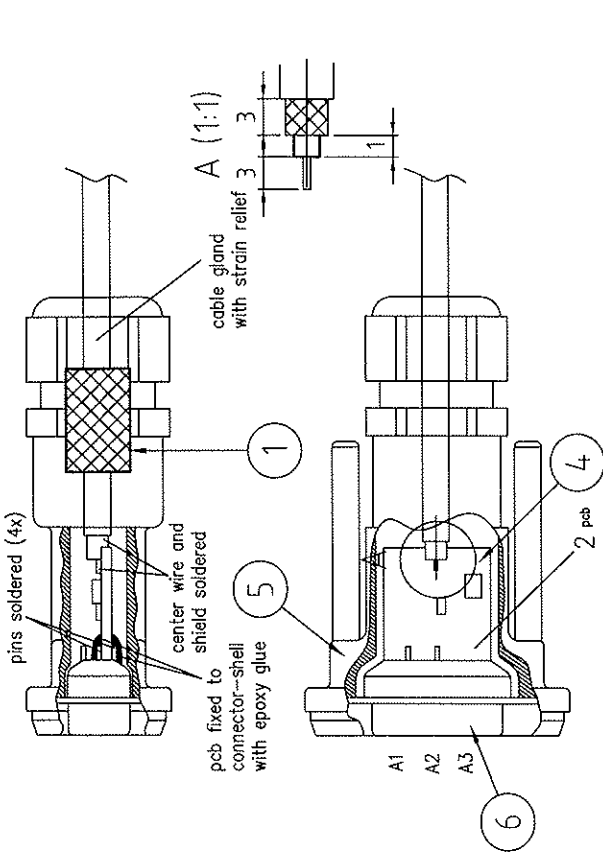
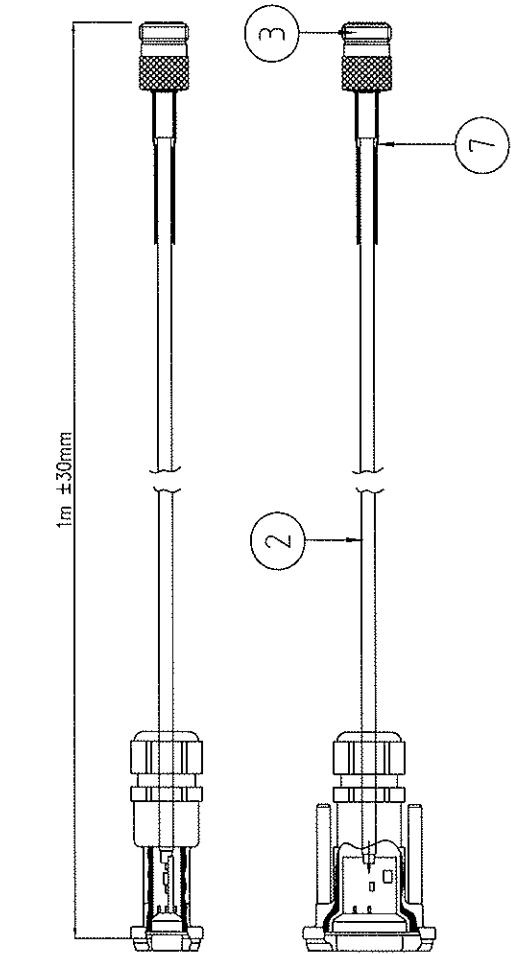

schematic diagram

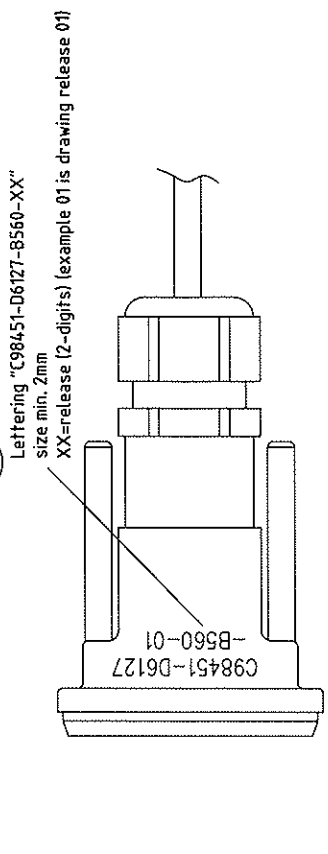

Lettering "C98451-D6127-B560-XX"  
size min. 2mm  
XX=release (2-digits) (example 01 is drawing release 01)

Electric specifications  
 VHF - VHF/GPS antenna : <-0,5db @158MHz  
 VHF - GPS : <-35db @158MHz  
 GPS - VHF/GPS antenna : <-2,5db @1575MHz

remark:  
 items 2 og 3 will not meet the EN60945 environment requirements as:  
 -protection IP67  
 -salt spray test  
 -resistiveness to corrosion

delivery conditions:  
 cable rolled up to a ring, packed into a PE-bag

1	7	Krympselange Ø9/3	ATUM	Kapplengde: 30mm
1	6	Koax. plugg		4003W35XX76A9X fra CONEC
1	5	Vannrett hus		165x14829x fra CONEC
1	4	Printkort	AC17-AIS-MAR-IA-0001	
1	3	N-plugg full crimp		Hunn
1	2	Kabel		RG-58 sort L=960mm
5	1	Bylase	AC17-AIS-MAR-T-0001 PDM	
Ant.	Pos	Navn	Legenr.	Material
Dato	23.09.2003	Tegnet	ibe	Gøkkjent
				Målestokk
				i:2
				Erstatterfor
				Erstatter av

**COMROD**  
 AIS/F/Nauticast  
 Sammenstilling

Tegnarkiv AC17-AIS-MAR-T-0002 Side  
 Filnavn  
 Overflate

# Technische Daten / Specification :

Spannungsversorgung / power supply: 5±0,5 DC

Strom / current: 27±5mA

Betriebstemperaturbereich / operation temperature: -30°C to +80°C

Schutzart / type of enclosure: waterproof

magnetischer Schutzabstand / magnetic safety distance: 0,3m/11,81inch

Gewicht Antenne / weight antenna: 160±10g (ohne Kabel/without cable)

Gewicht Herterung / weight antenna mount: 800g

Farbe/color: weiss/withe

Innengewinde 1"-14UNS-2A /  
internal thread 1"-14UNS-2A

Antennen-Kabel mit  
TNC-Stecker Buchse /  
antenna-cable with  
TNC-Connector female

Gewinde 1"-14 UNS-2A /  
pole thread 1"-14 UNS-2A

Antennenhalterung /  
antenna mount /

Horizontale Befestigung /  
horizontal mount

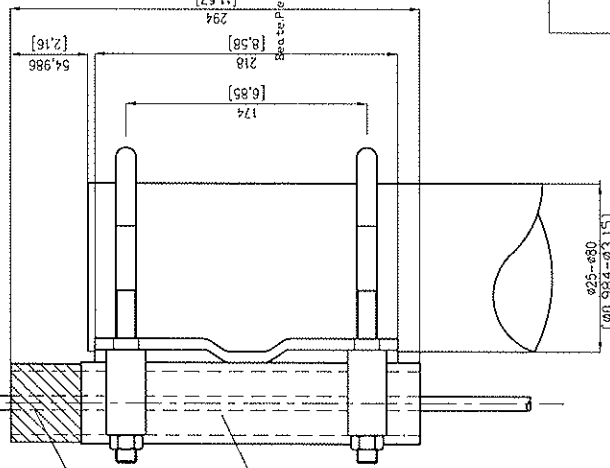
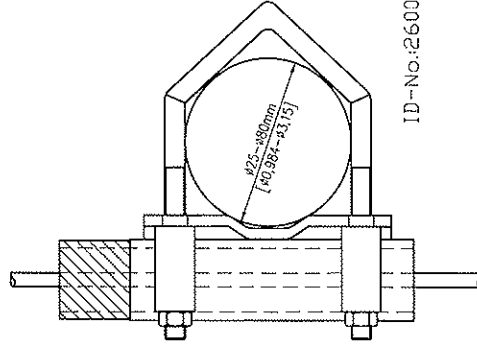
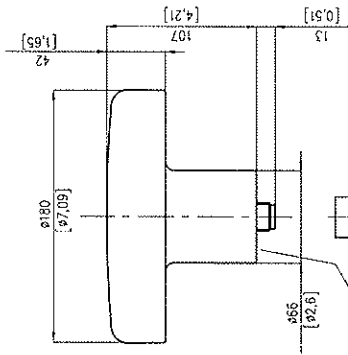

Set ID-No.: 2600654

ID-No.: 2600658

ID-No.: 2600658

DISTANCE FROM MAGNETIC COMPASS

STANDARD TYPE: 0,3 m

STEERING TYPE: 0,3 m



mm  
[INCH]

SCALE - WEIGHT: 0,96 Kg

CAD

DRAWING TITLE  
DIMENSIONAL DRAWING  
FOR  
GPS antenna Marine II with  
antenna mount

DRAWING NO.

NAU-X601DWG

SH 1  
OF 1

DATE 29.04.2003  
DR DP  
ACCEPTED AL 20.05.2003

NAUTICAST

LTR REVISIONS DATE

1 20.05.03

8  
7  
6  
5  
4  
3  
2  
1

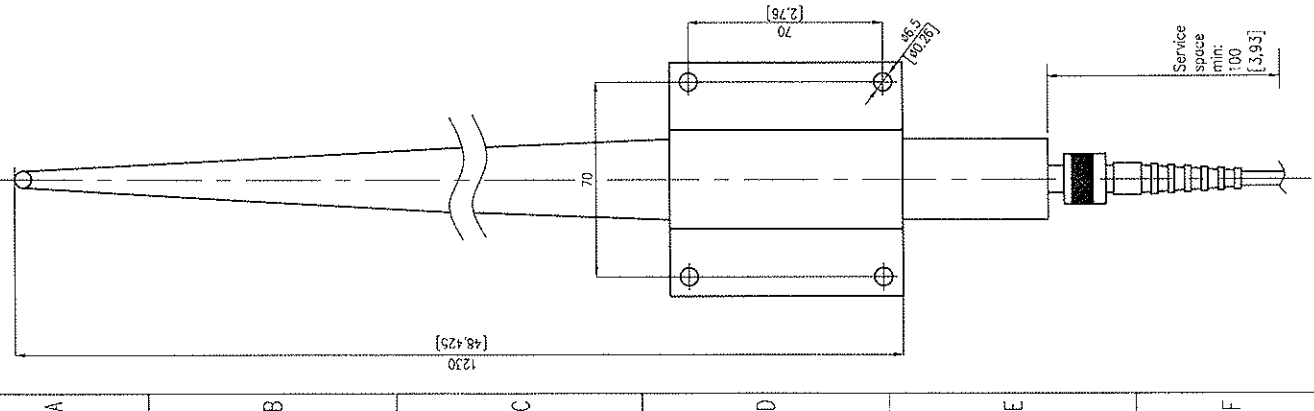

Elektrische Daten /  
Electrical specification :

übertragener Frequenzbereich /  
Frequency range:  
156 - 162MHz, VSWR < 1.5:1  
145 - 165MHz, VSWR < 2:1  
Normal impedance: 50ohm  
Bemessungsleistung / Power rating: 100W  
Connector: UHF female is standard  
Gleichstrom geerdet / DC-grounded: yes

Mechanische Daten /  
Mechanical specification :

Höhe / Height: 1,25m (4ft)  
Gewicht / Weight: 1kg, including U-bolts  
Wind rating: 55m/s = 125mph  
Temperaturanzeige / Temperature range:  
-55°C, +7°C; -67°F, +160°F

DISTANCE FROM MAGNETIC COMPASS  
STEERING TYPE:

STANDARD TYPE:	...m
min	[INCH]
DATE	29.04.2003
DR	DP
ACCEPTED	AL 20.05.2003

LTR	REVISIONS	DATE
1		20.05.03

CAD

SCALE	-	WEIGHT:	1,0 Kg
-------	---	---------	--------

DRAWING TITLE	
DIMENSIONAL DRAWING FOR VHF antenna AV7	
DRAWING NO.	NAU-B611DWG
SH	1
OF	1



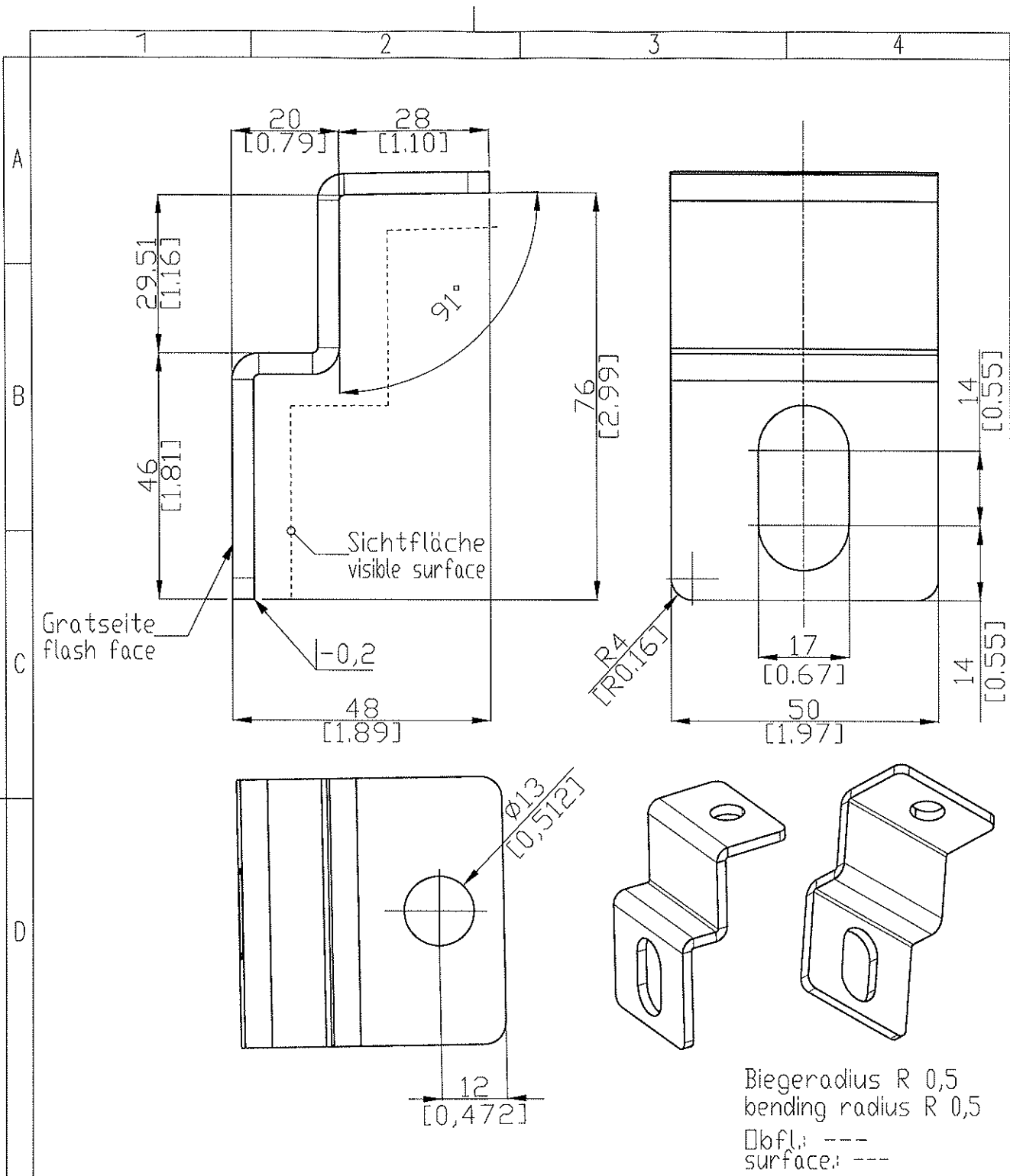

DISTANCE FROM MAGNETIC COMPASS  
 STANDARD TYPE: ...m      STEERING TYPE: ...m

CAD

SCALE -      WEIGHT: 0,021 Kg

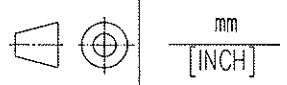

DRAWING TITLE  
 DIMENSIONAL DRAWING  
 FOR  
 mounting bracket

DRAWING NO. NAU-D501DWG      SH 1 OF 1

1	REVISIONS	DATE	DATE	DATE
		20.05.03		
LTR				



For this technical document all rights reserved.

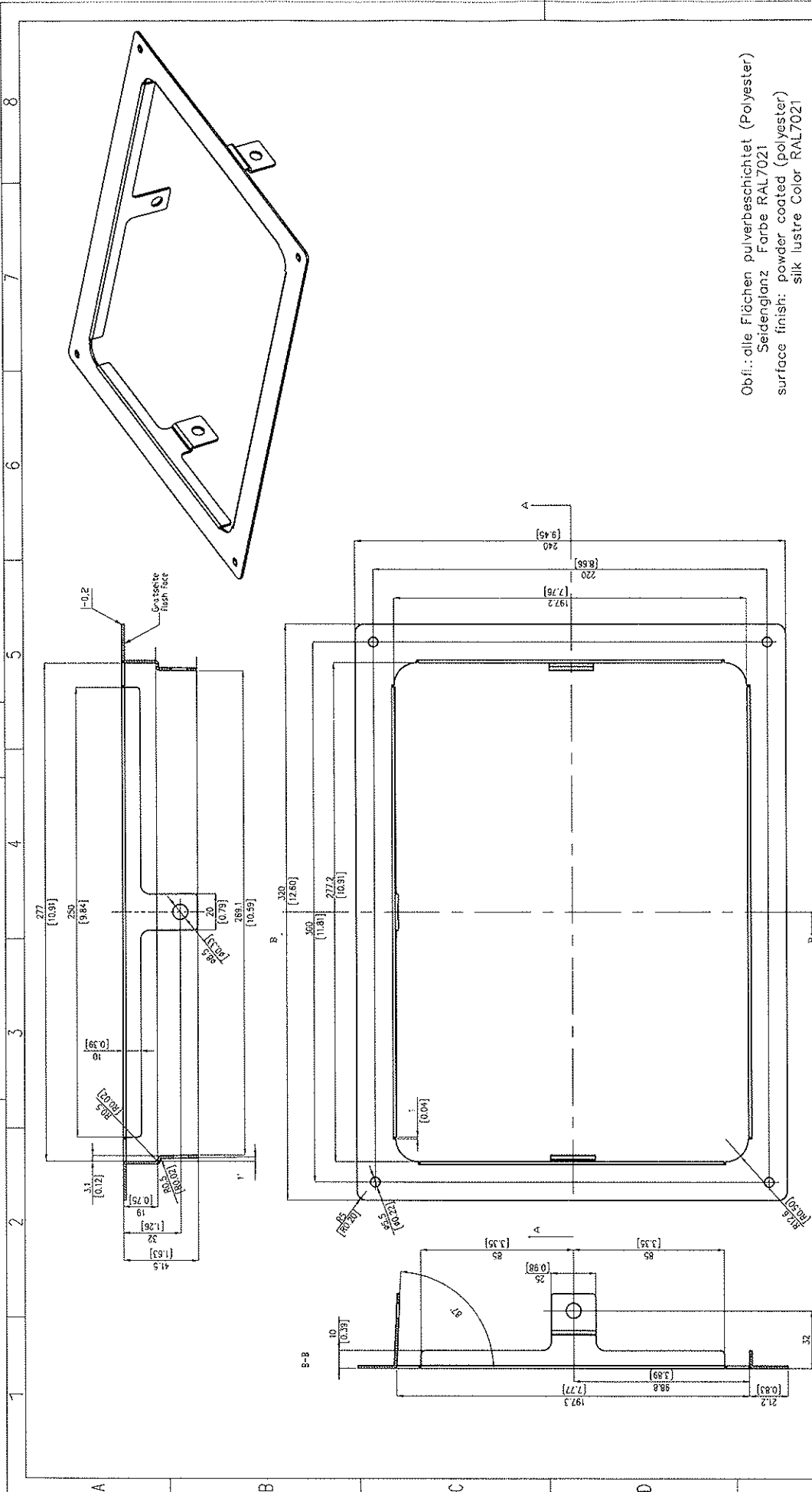

Obli.: alle Flächen pulverbeschichtet (Polyester)  
 Seidenglanz Farbe RAL7021  
 surface finish: powder coated (polyester)  
 silk lustre Color RAL7021

DISTANCE FROM MAGNETIC COMPASS		CAD	
STANDARD TYPE: ...m		SCALE: -	
STEERING TYPE: ...m		WEIGHT: 0.36 Kg	
DRAWING TITLE			
DIMENSIONAL DRAWING			
FOR mounting frame			
DRAWING NO. NAU-D500DWG			
ACCEPTED AL 20.05.2003			
<b>NAUTICAST</b>			
DATE 20.05.03		DATE	
LTR 1		REVISIONS	
DR 29.04.2003		DATE	
DP		DATE	
ACCEPTED AL 20.05.2003		DATE	
SH 1		OF 1	

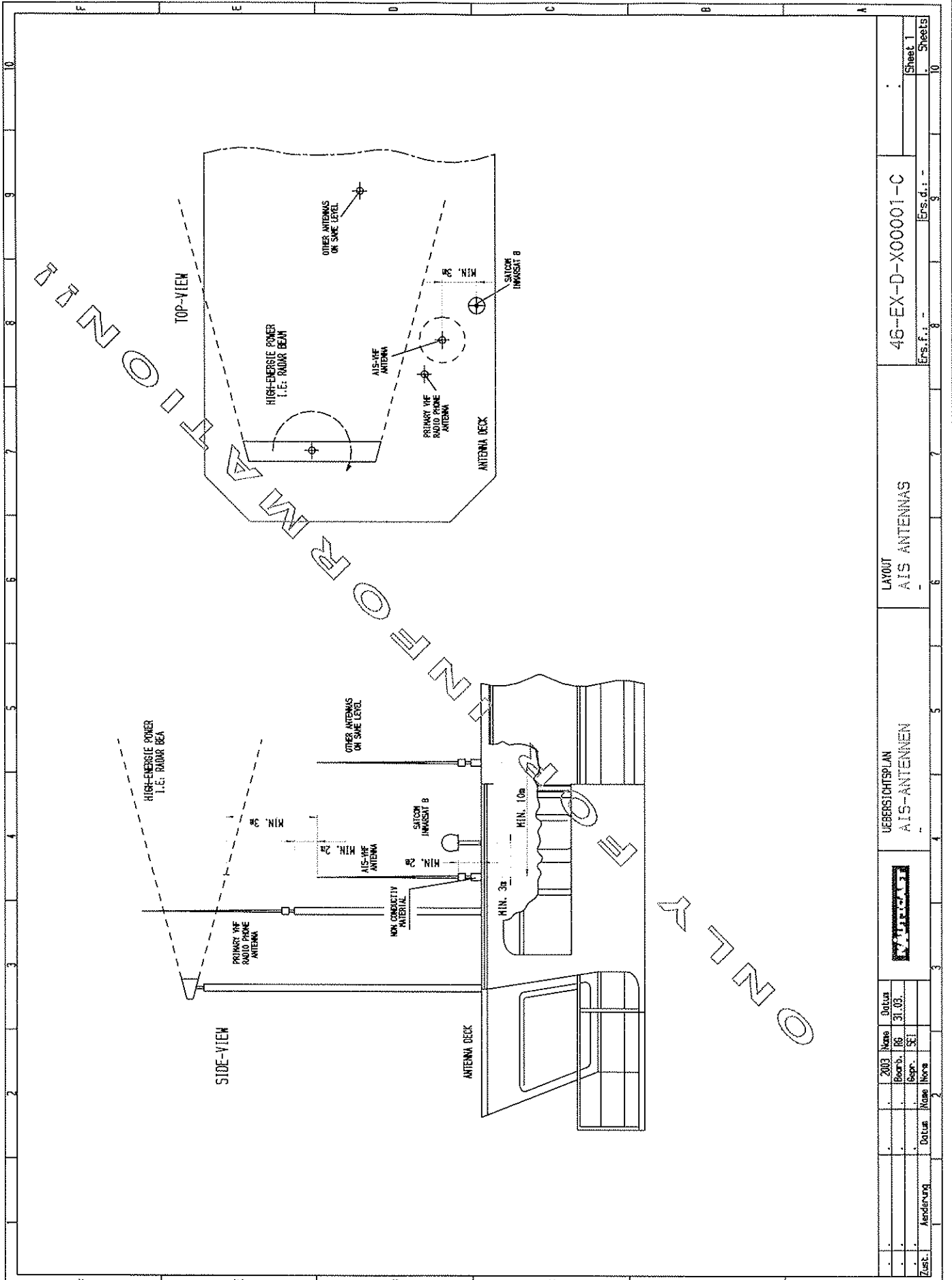

Zust.	Änderung	Datum		Name		2003	Name	Datum	Boorb.	R6	31.03.	Sacr.	SF1	Ers.f.i.	Ers.d.	9	8	7	6	LAYOUT AIS ANTENNAS	46-EX-D-X00001-C	Sheet 1
		10		10																		



# Bundesrepublik Deutschland

Federal Republic of Germany

## Bundesamt für Seeschifffahrt und Hydrographie

Federal Maritime and Hydrographic Agency

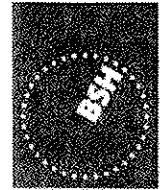

BUNDESAMT FÜR  
SEESCHIFFFAHRT  
UND  
HYDROGRAPHIE

### EC TYPE EXAMINATION (MODULE B) CERTIFICATE

This is to certify that:

Bundesamt für Seeschifffahrt und Hydrographie, specified as a "notified body" under the terms of „Schiffssicherheitsgesetz“ of 9. September 1998 (BGBl. I, p. 2860) modified last 17. October 2005 (BGBl. I, p. 2985), did undertake the relevant type approval procedures for the equipment identified below which was found to be in compliance with the Navigation requirements of Marine Equipment Directive (MED) 96/98/EC as modified by Directive 2002/75/EC.

Applicant **ACR Electronics Europe GmbH**  
 Address **Mariahilfer Straße 50/2/11, 1070 VIENNA, AUSTRIA**

Manufacturer **ACR Electronics, Inc.**  
 Address **5757 Ravenswood Road, FORT LAUDERDALE, FL-33312-6645, USA**

Annex A.1 Item **4.32 / Universal automatic identification system equipment (AIS)**  
 (No & item designation)

Product Name **X-Pack DS**

Trade Name(s) **see page 2**

#### Specified Standard(s)

IMO MSC.74(69) Annex 3	IEC 61993-2 (2001)
ITU-R M 1371-1 (Class A)	IEC 61162-1 (2000), -2 (1998)
IALA Technical Clarifications of Rec. ITU-R M, 1371-1 (Edition 1.3)	IEC 60945 (1996)
ITU-R M.825-3	IEC 61108-1 (1996)
ITU-R M. 1084-3	

This certificate remains valid unless cancelled, expired or revoked.

Date of issue: 2006-05-08

Issued by: Bundesamt für Seeschifffahrt und Hydrographie  
Bernhard-Nocht-Str. 78, 20359 Hamburg, Germany  
Notified body 0735

Expiry date: 2009-04-30

Certificate No.: **BSH/4612/4320296/06**

This certificate consists of 2 pages.



by order

*Schulz-Reifer*  
Schulz-Reifer



**Components necessary for operation:**

Components necessary for operation	Part No.	Remarks
X-Pack DS	NAU-A 002	Software-Version: 2.0x
Connection Box	NAU-B 401	
VHF antenna Glomex	NAU-B 610	or equivalent
VHF antenna Marine II	NAU-B 601	or equivalent

The internal GPS sensor of the X-Pack DS is used as a backup sensor for position reporting

**Documentation:**

User Manual: Version 1.0x dated: 2002-12  
 Installation Manual: Version 1.0x dated: 2003-03

**Trade names:**

The equipment is also available under the following trade names:

		Nauticast part No. of AIS transponder unit:
Raytheon Marine	RM 808 AIS	NAU-A 023
ACR	GlobalWatch UAIS	NAU-A 051
Marine Technologies	Bridgemate AIS	NAU-A 061
ACR	Nauticast	NAU-A 007

**Limitations on the acceptance or use of the product:**

----

**Places of production:**

----

**Notes:**

The manufacturer shall inform Bundesamt für Seeschifffahrt und Hydrographie, as the notified body, of any modifications to the type-tested product(s) that may affect compliance with the requirements or conditions laid down for use of the product(s).

In case the specified regulations or standards are amended during the validity of this certificate, the product(s) must be re-certified before being placed on board vessels to which such amended regulations or standards apply.

The Mark of Conformity (wheelmark) may only be affixed to the type approved equipment, and a Manufacturer's Declaration of Conformity may only be issued, if the product quality system fully complies with the Marine Equipment Directive and is certified by a notified body against ANNEX B module D, E, or F of the Directive.

**Example for the Application of the "Mark of Conformity":**

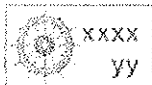

xxxx number of the Notified Body responsible for quality surveillance module  
 yy Last two digits of the year in which the mark is affixed

**Notice on legal remedies available:**

Objection to this document may be filed within one month after notification. The objection must be filed in writing to, or put on record at, Federal Maritime and Hydrographic Agency, Bernhard-Nocht-Str. 78, 20359 Hamburg, Germany



**Bundesrepublik Deutschland**

Federal Republic of Germany

**Bundesamt für Seeschifffahrt und Hydrographie**

Federal Maritime and Hydrographic Agency

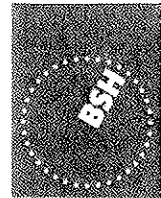

BUNDESAMT FÜR  
SEESCHIFFFAHRT  
UND  
HYDROGRAPHIE

## EC QUALITY SYSTEM (MODULE D) CERTIFICATE

Bundesamt für Seeschifffahrt und Hydrographie (Federal Maritime and Hydrographic Agency) as the notified body performing EC conformity assessment procedures in compliance with EC Council Directive 96/98/EC of 20 December 1996 on Marine Equipment, last amended by EC Council Directive 2002/75/EC of 2 September 2002, hereby certifies that the manufacturer

ACR Electronics, Inc.  
5757 Ravenswood Road  
Fort Lauderdale, Florida 33312  
USA

maintains and applies a quality system in accordance with the requirements of the Maritime Equipment Directive Annex B, Module D.

Scope:

- A.1/4.18 9 GHz SAR Transponder (SART)
- A.1/5.6 406 MHz EPIRB (COSPAS-SARSAT)
- A.1/4.32 Universal automatic identification system equipment (AIS)

References: see overleaf

\*\*\*\*\*

Date of issue: 27<sup>th</sup> July 2004

Issued by: Bundesamt für Seeschifffahrt und Hydrographie

Expiry date: 04<sup>th</sup> May 2007

Identification number 0735

Registration no.: BSH-051-05-2004/3

This certificate consists of 2 pages

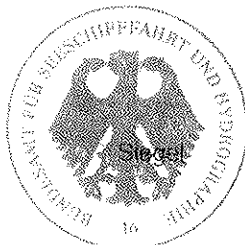

by order

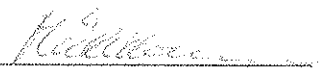
  
Mülhhausen



**Places of production** (if different from client or where there are several)

\*\*\*

**Restrictions:**

\*\*\*

**References:**

Item		Module B Certificate data		
		Registration number	Date of issue	Notified Body
A.1/4.18	9 GHz SAR Transponder (SART)	QQ-MED-48/03-01	04.11.2003	0191
A.1/4.18	9 GHz SAR Transponder (SART)	QQ-MED-48/03-02	04.11.2003	0191
A.1/4.32	Universal automatic identification system equipment (AIS)	734.2/0051-2/2004	01.05.2004	0735
A.1/5.6	406 MHz EPIRB (COSPAS-SARSAT)	BSH/6492/0039/01	01.08.2001	0735
A.1/5.6	406 MHz EPIRB (COSPAS-SARSAT)	050564/99	18.10.1999	0735

**Notes:**

This certificate authorises in conjunction with the EC Type Examination (Module B) Certificate of the equipment listed in the scope to affix the "Mark of Conformity" (wheelmark).

This certificate loses its validity if the manufacturer makes any changes or modifications to the approved quality system, which have not been notified to, and agreed with the notified body named on this certificate and/or after lapse of time, withdrawal or revocation of the EC Type Examination (Module B) Certificate.

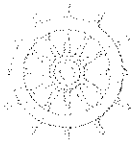
**"Wheelmark" Format and application:**

yy Last two digits of the year in which mark is affixed.  
0735 Notified Body number undertaking quality surveillance

0735/yy

example

**Notice on legal remedies available:**

Objection to this document may be filed within one month after notification. The objection must be filed in writing to, or put on record at, Federal Maritime and Hydrographic Agency, Bernhard-Nocht-Str. 78, 20359 Hamburg, Germany



## EG - Konformitätserklärung CE - Declaration of Conformity

Diese Konformitätserklärung bestätigt, dass das unten benannte Produkt den Auflagen der EC Council Directive 96/98/EC vom 20 Dezember 1996 für maritime Ausrüstung, geändert durch die EC Council Directive 2002/75/EC vom 2. September 2002 entspricht und von der benannten Stelle Nr. 0735 (BSH) typengeprüft. Darüber ist die Konformität zum Standard „Vessel Tracking and Tracing Standard for Inland Navigation Edition 1.0“ vom 31.5.2006 gewährleistet.

This declaration of conformity certified that the mentioned equipment is in compliance with EC Council Directive 96/98/EC of 20 December 1996 on Marine Equipment, last amended by EC Council Directive 2002/75/EC of 2 September 2002 and has been type examined by the Notified Body No. 0735 (BSH). The device is in full compliance to the Standard „Vessel Tracking and Tracing Standard for Inland Navigation Edition 1.0“ from 31<sup>st</sup> of May 2006.

<b>Produktbezeichnung:</b> name of product	<b>Nauticast Inland AIS</b>
OEM Name: Trade Name	X-Pack DS Inland AIS
Zertifikate der benannten Stelle: Certificates from the notified Body	EC Type Examination (Module B) Certificate BSH/6412/4320296/06  EC Quality System (Module D) Certificate BSH-051-05-2004/3
Spezifizierte Standards: Specified Standard(s)	IMO MSC.74(69) Annex 3 ITU-R M.1371-1 (Class A) IALA Technical Clarifications of Rec. ITU-R M.1371-1 ITU-R M.825-3 ITU-R M1084-3 IEC 61993-2 (2002) IEC 61162-1 (2000), -2 (1998) IEC 60945 (1996) IEC 61108-1 (1996) Vessel Tracking and Tracing Standard for Inland Navigation Edition 1.0
Dokument- Nr.: document-no :	<b>2006/02</b>
Hersteller: Manufacturer	<b>ACR Electronics Europe GmbH</b>
Anschrift: address	Handelskai 388 / Top 632 A-1020 Vienna, Austria
Ort, Datum: place, date	Vienna, 2006-07-12
Unterschrift: signature	  Andreas Lesch Chief Technology Officer

Diese Erklärung bescheinigt die Übereinstimmung mit den genannten Richtlinien, ist jedoch keine Zusicherung von Eigenschaften.  
Die Sicherheitshinweise der mitgelieferten Produktdokumentation sind zu beachten.  
This declaration certifies the compliance with the indicated directives but implies no warranty of properties.  
The safety instructions of the accompanying product documentation shall be observed.

ISO 9001:2000 Zertifizierung / ISO 9001:2000 Certification  
ACR Electronics Europe GmbH hat ein Qualitätsmanagement System nach ISO 9001:2000 implementiert, und ist seit Juli 2003 ISO-zertifiziert.  
ACR Electronics Europe GmbH maintains a Quality Management System according to ISO 9001:2000, and received ISO certification in July 2003.





## Konformitätserklärung Declaration of Conformity

Diese Konformitätserklärung bestätigt, dass das unten benannte Zubehör gleich oder besser dem im untenstehenden Zertifikat ausgewiesenen Zubehör ist.

This declaration of conformity certifies that the mentioned accessory is equal or better to the equipment stated in the beyond Certificate.

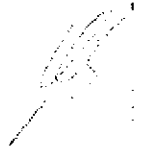
<b>Produktbezeichnung:</b> name of product	<b>Nauticast (Automatic Identification System)</b>
OEM Name: Trade Name	X-Pack DS, RM808AIS, GlobalWatch UAIS, Bridgemate AIS
Zertifikate der benannten Stelle: Certificates from the notified Body	EC Type Examination (Module B) Certificate BSH/6412/4320296/06  EC Quality System (Module D) Certificate BSH-051-05-2004/3
Spezifizierte Standards: Specified Standard(s)	IMO MSC.74(69) Annex 3 ITU-R M.1371-1 (Class A) IALA Technical Clarifications of Rec. ITU-R M.1371-1 ITU-R M.825-3 ITU-R M1084-3 IEC 61993-2 (2002) IEC 61162-1 (2000), -2 (1998) IEC 60945 (1996) IEC 61108-1 (1996)
Zubehörtyp : Type of Accessory	<b>VHF Antenna</b> <b>ACR AIS-A3200</b>
Nauticast Part.No.:	<b>NAU-B 614 / 2628</b>
Einschränkungen / Hinweise : Restrictions / Comments	verlegte Kabellänge < 40 m installed Cable length < 40m
Dokument- Nr. : document-no :	<b>2006-07</b>
Hersteller: Manufacturer	<b>ACR Electronics Europe GmbH</b>
Anschrift: address	Handelskai 388 / Top 632 A-1020 Vienna, Austria
Ort, Datum: place, date	Vienna, 2006-07-12
Unterschrift: signature	  Andreas Lesch Chief Technology Officer

Diese Erklärung bescheinigt die Übereinstimmung mit den genannten Richtlinien, ist jedoch keine Zusicherung von Eigenschaften.

Die Sicherheitshinweise der mitgelieferten Produktdokumentation sind zu beachten.

This declaration certifies the compliance with the indicated directives but implies no warranty of properties.

The safety instructions of the accompanying product documentation shall be observed.

ISO 9001:2000 Zertifizierung / ISO 9001:2000 Certification

ACR Electronics Europe GmbH hat ein Qualitätsmanagement System nach ISO 9001:2000 implementiert, und ist seit Juli 2003 ISO-zertifiziert.

ACR Electronics Europe GmbH maintains a Quality Management System according to ISO 9001:2000, and received ISO certification in July 2003.



## Konformitätserklärung Declaration of Conformity

Diese Konformitätserklärung bestätigt, dass das unten benannte Zubehör gleich oder besser dem im untenstehenden Zertifikat ausgewiesenen Zubehör ist.

This declaration of conformity certifies that the mentioned accessory is equal or better to the equipment stated in the beyond Certificate.

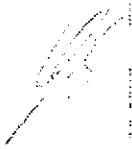
Produktbezeichnung: name of product	Nauticast (Automatic Identification System)
OEM Name: Trade Name	X-Pack DS, RM808AIS, GlobalWatch UAIS, Bridgemate AIS
Zertifikate der benannten Stelle: Certificates from the notified Body	EC Type Examination (Module B) Certificate BSH/6412/4320296/06 EC Quality System (Module D) Certificate BSH-051-05-2004/3
Spezifizierte Standards: Specified Standard(s)	IMO MSC.74(69) Annex 3 ITU-R M.1371-1 (Class A) IALA Technical Clarifications of Rec. ITU-R M.1371-1 ITU-R M.825-3 ITU-R M1084-3 IEC 61993-2 (2002) IEC 61162-1 (2000), -2 (1998) IEC 60945 (1996) IEC 61108-1 (1996)
Zubehörtyp : Type of Accessory	GPS Antenna Procom GPS 4 Antenna
Nauticast Part.No.:	NAU-B 602 / 2622
Einschränkungen / Hinweise : Restrictions / Comments	verlegte Kabellänge < 40 m installed Cable length < 40m
Dokument- Nr. : document-no :	2006-06
Hersteller: Manufacturer	ACR Electronics Europe GmbH
Anschrift: address	Handelskai 388 / Top 632 A-1020 Vienna, Austria
Ort, Datum: place, date	Vienna, 2006-07-12
Unterschrift: signature	 Andreas Lesch Chief Technology Officer

Diese Erklärung bescheinigt die Übereinstimmung mit den genannten Richtlinien, ist jedoch keine Zusicherung von Eigenschaften.

Die Sicherheitshinweise der mitgelieferten Produktdokumentation sind zu beachten.

This declaration certifies the compliance with the indicated directives but implies no warranty of properties.

The safety instructions of the accompanying product documentation shall be observed.

ISO 9001:2000 Zertifizierung / ISO 9001:2000 Certification

ACR Electronics Europe GmbH hat ein Qualitätsmanagement System nach ISO 9001:2000 implementiert, und ist seit Juli 2003 ISO-zertifiziert.

ACR Electronics Europe GmbH maintains a Quality Management System according to ISO 9001:2000, and received ISO certification in July 2003.



## Konformitätserklärung Declaration of Conformity

Diese Konformitätserklärung bestätigt, dass das unten benannte Zubehör gleich oder besser dem im untenstehenden Zertifikat ausgewiesenen Zubehör ist.

This declaration of conformity certifies that the mentioned accessory is equal or better to the equipment stated in the beyond Certificate.

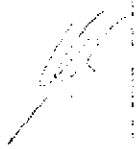
<b>Produktbezeichnung: name of product</b>	<b>Nauticast (Automatic Identification System)</b>
OEM Name: Trade Name	X-Pack DS, RM808AIS, GlobalWatch UAIS, Bridgemate AIS
Zertifikate der benannten Stelle: Certificates from the notified Body	EC Type Examination (Module B) Certificate BSH/6412/4320296/06  EC Quality System (Module D) Certificate BSH-051-05-2004/3
Spezifizierte Standards: Specified Standard(s)	IMO MSC.74(69) Annex 3 ITU-R M.1371-1 (Class A) IALA Technical Clarifications of Rec. ITU-R M.1371-1 ITU-R M.825-3 ITU-R M1084-3 IEC 61993-2 (2002) IEC 61162-1 (2000), -2 (1998) IEC 60945 (1996) IEC 61108-1 (1996)
Zubehörtyp : Type of Accessory	<b>Combined GPS/VHF Antenna</b> Comrod AC17 combined GPS/VHF Antenna + Splitter (in Cable integrated)
Nauticast Part.No.:	<b>NAU-B 620 / 2624</b>
Einschränkungen / Hinweise : Restrictions / Comments	verlegte Kabellänge < 40 m installed Cable length < 40m
Dokument- Nr. : document-no :	<b>2006-05</b>
Hersteller: Manufacturer	<b>ACR Electronics Europe GmbH</b>
Anschrift: address	Handelskai 388 / Top 632 A-1020 Vienna, Austria
Ort, Datum: place, date	Vienna, 2006-07-12
Unterschrift: signature	  Andreas Lesch Chief Technology Officer

Diese Erklärung bescheinigt die Übereinstimmung mit den genannten Richtlinien, ist jedoch keine Zusicherung von Eigenschaften.

Die Sicherheitshinweise der mitgelieferten Produktdokumentation sind zu beachten.

This declaration certifies the compliance with the indicated directives but implies no warranty of properties.

The safety instructions of the accompanying product documentation shall be observed.

ISO 9001:2000 Zertifizierung / ISO 9001:2000 Certification

ACR Electronics Europe GmbH hat ein Qualitätsmanagement System nach ISO 9001:2000 implementiert, und ist seit Juli 2003 ISO-zertifiziert.

ACR Electronics Europe GmbH maintains a Quality Management System according to ISO 9001:2000, and received ISO certification in July 2003.



# Konformitätserklärung Declaration of Conformity

Diese Konformitätserklärung bestätigt, dass das unten benannte Zubehör gleich oder besser dem im untenstehenden Zertifikat ausgewiesenen Zubehör ist.

This declaration of conformity certifies that the mentioned accessory is equal or better to the equipment stated in the beyond Certificate.

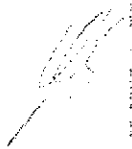
<b>Produktbezeichnung: name of product</b>	<b>Nauticast (Automatic Identification System)</b>
<b>OEM Name: Trade Name</b>	X-Pack DS, RM808AIS, GlobalWatch UAIS, Bridgemate AIS
<b>Zertifikate der benannten Stelle: Certificates from the notified Body</b>	EC Type Examination (Module B) Certificate BSH/6412/4320296/06  EC Quality System (Module D) Certificate BSH-051-05-2004/3
<b>Spezifizierte Standards: Specified Standard(s)</b>	IMO MSC.74(69) Annex 3 ITU-R M.1371-1 (Class A) IALA Technical Clarifications of Rec. ITU-R M.1371-1 ITU-R M.825-3 ITU-R M1084-3 IEC 61993-2 (2002) IEC 61162-1 (2000), -2 (1998) IEC 60945 (1996) IEC 61108-1 (1996)
<b>Zubehörtyp : Type of Accessory</b>	<b>VHF Antenna Comrod AV-7</b>
<b>Nauticast Part.No.:</b>	<b>NAU-B 611 / 2621</b>
<b>Einschränkungen / Hinweise : Restrictions / Comments</b>	verlegte Kabellänge < 40 m installed Cable length < 40m
<b>Dokument- Nr. : document-no :</b>	<b>2006-04</b>
<b>Hersteller: Manufacturer</b>	<b>ACR Electronics Europe GmbH</b>
<b>Anschrift: address</b>	Handelskai 388 / Top 632 A-1020 Vienna, Austria
<b>Ort, Datum: place, date</b>	Vienna, 2006-07-12
<b>Unterschrift: signature</b>	  Andreas Lesch Chief Technology Officer

Diese Erklärung bescheinigt die Übereinstimmung mit den genannten Richtlinien, ist jedoch keine Zusicherung von Eigenschaften.

Die Sicherheitshinweise der mitgelieferten Produktdokumentation sind zu beachten.

This declaration certifies the compliance with the indicated directives but implies no warranty of properties.

The safety instructions of the accompanying product documentation shall be observed.

ISO 9001:2000 Zertifizierung / ISO 9001:2000 Certification

ACR Electronics Europe GmbH hat ein Qualitätsmanagement System nach ISO 9001:2000 implementiert, und ist seit Juli 2003 ISO-zertifiziert.

ACR Electronics Europe GmbH maintains a Quality Management System according to ISO 9001:2000, and received ISO certification in July 2003.

# Quick Replacement Guide

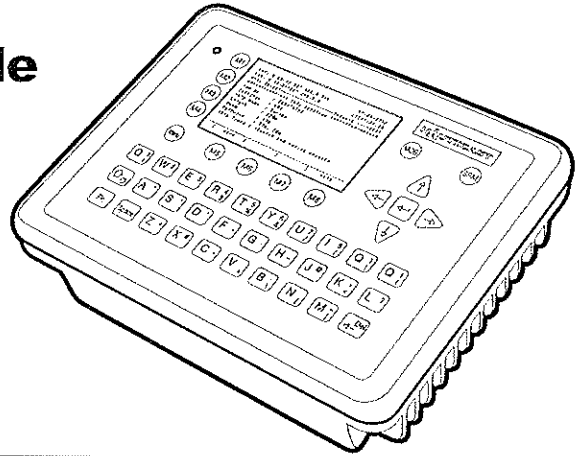

## 1. Prepare the following tools:

Screwdrivers, spanners

User Password: your personal password

(factory default setting is 'NAUT')

## 2. Read out your Transponder configuration

Steps to do this:

Press	Menu	
Press	<b>2</b>	2.AIS Status
Press	<b>2</b>	2.Own Ship Data

Write down the current configuration settings here:

IMO No. :	<input type="text"/>	Dest :	<input type="text"/>
ShipName :	<input type="text"/>	EAT :	<input type="text"/>
ShipType :	<input type="text"/>	MMSI :	<input type="text"/>
Length :	<input type="text"/>	CS :	<input type="text"/>
Cargo :	<input type="text"/>	Beam :	<input type="text"/>
Draught :	<input type="text"/>		

Press	Menu	
Press	<b>4</b>	4.Ship Settings
Password	<b>[UserPassword] [Enter←]</b>	

Write down the current configuration settings here:

RefPtExt:	A	<input type="text"/>	B	<input type="text"/>	C	<input type="text"/>	D	<input type="text"/>	RefPtInt:	A	<input type="text"/>	B	<input type="text"/>	C	<input type="text"/>	D	<input type="text"/>
-----------	---	----------------------	---	----------------------	---	----------------------	---	----------------------	-----------	---	----------------------	---	----------------------	---	----------------------	---	----------------------

Press	Menu	
Press	<b>5</b>	5.Transponder Configuration
Password	<b>[UserPassword] [Enter←]</b>	
Press	<b>5</b>	5.Sensor Settings

Write down the current configuration settings here:

BaudRate Sensor1:	<input type="text"/>
BaudRate Sensor2:	<input type="text"/>
BaudRate Sensor3:	<input type="text"/>

Press	<b>M8</b>	Back
-------	-----------	------

## 3. Detach the device

3.1. Bracket Mounting

3.2. Frame Mounting

## 4. Disconnect cables

4.1. AIS-Cable to unscrew

4.2. VHF/GPS Cable to unscrew

## 5. Unpack the new Transponder

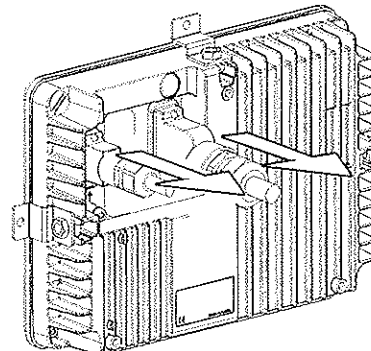

## 6. Connect cables

- 6.1. AIS-Cable to screw on
- 6.2. VHF/GPS Cable to screw on

## 7. Mount the replacement unit

- 7.1. Bracket Mounting
- 7.2. Frame Mounting

## 8. Key in the configuration settings from above:

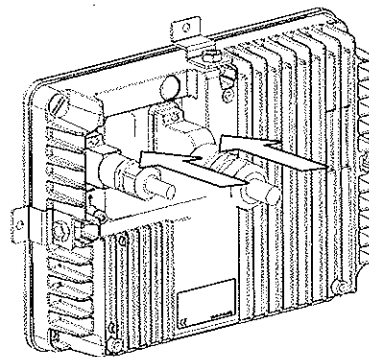

Following steps to key in the Configuration

Press	Menu	
Press	<b>6</b>	6. Service Configuration
Password	<b>NAUT [Enter←]</b>	(Default Factory Password)
Press	<b>3</b>	3. Change MMSI / IMO

Key in the configuration data from your list: (see page 1)

MMSI: | IMO No: |

Press	<b>M5</b>	Save
Press	<b>Menu</b>	
Press	<b>4</b>	4. Ship Settings
Password	<b>NAUT [Enter←]</b>	(Default Factory Password)

Key in the configuration data from your list: (see page 1)

CallSign: | ShipName: | Length: | Beam: | RefPtExt: | RefPtInt: | ShipType:  
 AxxCxx\* | AxxCxx\* |

\*(B and D are calculated by the AIS)

Press	<b>Menu</b>	
Press	<b>5</b>	5. Transponder Configuration
Password	<b>NAUT [Enter←]</b>	(Default Factory Password)
Press	<b>5</b>	5. Sensor Settings

Key in the configuration data from your list: (see page 1)

BaudRate Sensor1: | BaudRate Sensor2: | BaudRate Sensor3: |

Press	<b>M5</b>	Save
-------	-----------	------

## 9. Check the functionality

Press	<b>M2</b>	You should see correct values for LAT, LON, SOG, COG, and Time
Press	<b>M2</b>	You should see your Own Ship Data as noted down before.

### 9.1. Change your User Password

Press	<b>Menu</b>	
Press	<b>6</b>	6. Service Configuration
Password	<b>NAUT [Enter←]</b>	(Default Factory Password)
Press	<b>2</b>	2. User Password Settings
Press	<b>1</b>	1. Change User Password
Enter	<b>[new password]</b>	
Repeat	<b>[new password]</b>	
Press	<b>M5</b>	Save