

# PRODUCT SUPPORT MANUAL

Y1-03-0138  
Rev. H



## RCL-100D™

Remote Control Searchlight  
Master Controller  
Point Pad

**ACR Electronics, Inc.**  
5757 Ravenswood Road  
Fort Lauderdale, FL 33312  
+1(954) 981-3333 • Fax +1 (954) 983-5087  
[www.acrelectronics.com](http://www.acrelectronics.com)  
Email: [Info@acrelectronics.com](mailto:Info@acrelectronics.com)

# RCL-100D

## TABLE OF CONTENTS

<b><u>SECTION</u></b>	<b><u>TITLE</u></b>	<b><u>PAGE</u></b>
1.0	Forward	1
2.0	General	2
3.0	Searchlight	2
4.0	Remote Control System	2
5.0	URP-102 Point Pad™	3
6.0	URC-102 Master Controller	11
7.0	RCL-100D Specifications	15
8.0	Bulb Replacement	17
9.0	RCL-100D Searchlight Components	17
10.0	Remote Control System Components	18

<b><u>FIGURES</u></b>	<b><u>TITLE</u></b>	<b><u>PAGE</u></b>
Figure 1	Remote Control Searchlight System	1
Figure 2	Point Pad™ Connection Block Diagram	4
Figure 3	URP-102 Point Pad™ Functions	5
Figure 4	URP-102 Point Pad™ Surface Mount Case	6
Figure 5	URP-102 Point Pad™ Flush Mount Case	7
Figure 6	URP-102 Point Pad™ Surface Mount Case w/Gasket and Flush Mount Case with Gasket	8
Figure 7	URC-102 Master Controller Wiring Diagram	11
Figure 8	URC-102 Master Controller	12
Figure 9	Searchlight User Replaceable Parts List	14

# RCL-100D, 12/24V REMOTE CONTROL SEARCHLIGHT SYSTEM

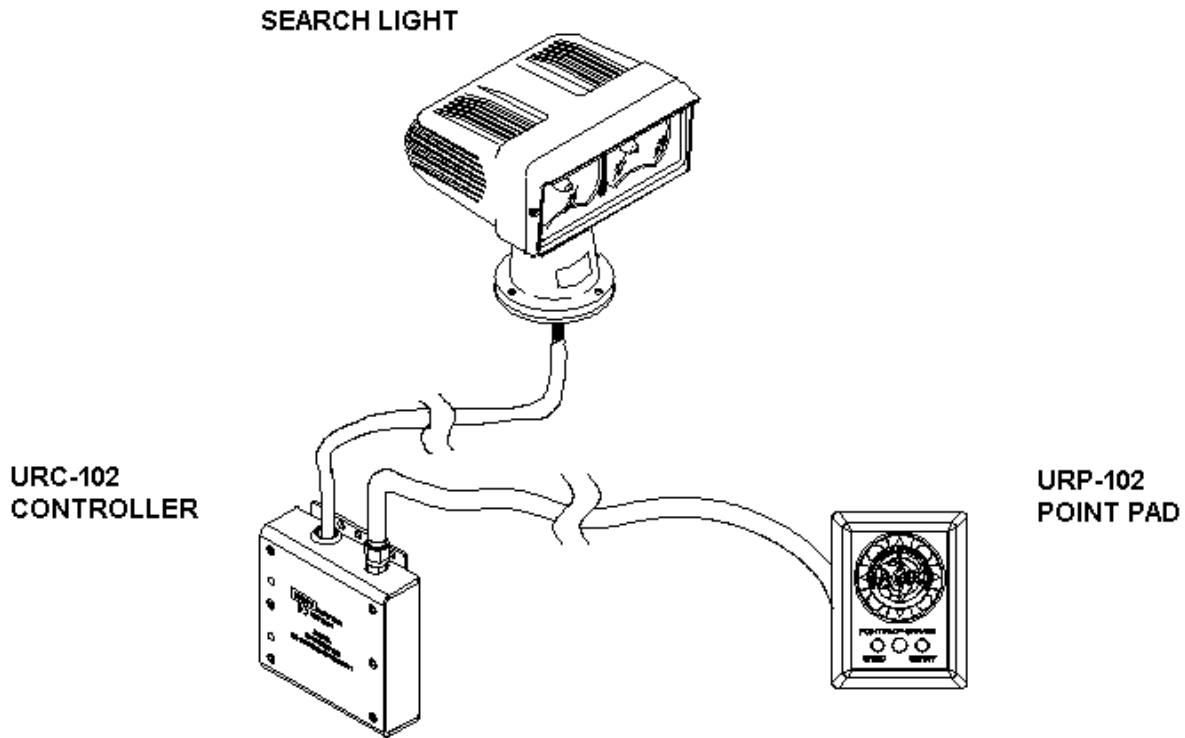

*FIGURE 1: REMOTE CONTROL SEARCHLIGHT SYSTEM*

## 1.0 FORWARD

Congratulations and thank you for purchasing the ACR **RCL-100D** Searchlight. The combination of computer aided design, high quality raw materials, and quality-controlled manufacturing produce a superior product. The Test Facility at ACR can reproduce some of the harshest environmental conditions known to man. This assures that the products we produce can stand up to the tough marine environment. With proper care and maintenance your searchlight will be in service for years to come.

ACR is proud to be ISO 9001 certified, the International Standard for Quality.

**Note:** It is important to read this entire instruction manual carefully for proper installation and operation of this product.

## 2.0 GENERAL

The RCL-100D was specially designed for mariners who require a high intensity remote controlled searchlight that can stand up to the tough marine environment.

The RCL-100D Searchlight System contains a narrow beam searchlight that produces 200,000 peak candle power by combining two 55W halogen lamps with our unique optical quality parabolic reflectors.

All functions of the Searchlight can be electrically operated by remote control from the pilot area of the vessel using the URP-102 Point Pad™, URC-102 Master Controller, and interconnect cable supplied with the RCL-100D. Searchlights equipped with the URC-102 Master Controller now have ACR's unique XRCiZ feature. The XRCiZ feature routinely operates all moving parts in the Searchlight to keep the motors and drive mechanism freely running.

## 3.0 SEARCHLIGHT

The sleek design and modern construction of the Searchlight body makes it attractive for recreational and commercial vessels. The Searchlight is totally enclosed and is made of rugged aluminum alloy. It is gasketed and finished to be resistant to the weather.

### Mounting

Make sure the area is clean and dry. The Searchlight can be mounted where desired, using appropriate length 3/16" diameter, stainless steel fasteners. Four (4) nylon shoulder washers are supplied with the RCL-100D Searchlight. The nylon washers prevent a galvanic reaction between the mounting hardware and the base of the Searchlight. Be sure these washers have been inserted in the base mounting holes and that the mounting base gasket is securely in place before bolting down. Silicone grease should be applied to the bottom of the gasket to help in waterproofing the unit. When mounting, be sure that the Searchlight is able to rotate 360° without hitting any obstructions. For the drilling hole pattern, refer to the Searchlight Mounting Template, supplied in the Mounting Templates.

**CAUTION: Do not mount the searchlight upside down. Moisture will not be able to drain from the inverted light head assembly.**

**NOTE:** The Searchlight should be left uncovered if the XRCiZ feature is enabled.

## 4.0 REMOTE CONTROL SYSTEM

The Remote Control System consists of the URC-102 Master Controller and the URP-102 Point Pad™. This system is compatible with 12 VDC and 24 VDC systems without modification. The Remote Control System may be used with 12 V or 24 V Searchlights, ***ONLY THE LAMPS IN THE LIGHT HEAD ASSEMBLY MUST BE CHANGED TO MATCH THE VOLTAGE RATING.***

## 5.0 URP-102 POINT PAD™

### Case Options

The URP-102 Point Pad™ is supplied as a surface mount unit (*see Figure 4*). A flush mount option is provided (*see Figure 5*). To switch mounting options, unscrew the six (6) screws on the unit's back plate and remove the front cover. Fit the Point Pad™ with the flush mount cover, replace the back plate, and screw the unit back together.

### Mounting

Both the surface mount and flush mount options require access to the backside of the mounting location. Make sure there are no obstructions behind the area where the switch is to be located (e.g. bulkheads, wires, plumbing, or hardware). Check in advance that the coax cable from the Master Controller can be routed to this location. Generally, the Point Pad™ should be mounted in a protected area.

Install the surface mount Point Pad™ by drilling 3 holes in the dashboard location using the Point Pad™ Surface Mount Template supplied in the Mounting Templates. Mount the Point Pad™ to the dashboard using the gasket, washers, and nuts supplied. Use a sealant around the bolt holes to protect from moisture intrusion.

When the flush mount option is selected, cut a rectangular hole in the dashboard location using the Point Pad™ Flush Mount Template supplied in the Mounting Templates. Use the gasket, washers, nuts, and the two U-Clamps provided to secure the Point Pad™. Use a sealant around the cut out to protect from moisture intrusion.

### Connecting to the Master Controller

The Point Pad™ communicates with the Master Controller via standard television type RG-59 coaxial cable. The connectors are standard "F" type television connectors. The connector on the back of the Point Pad™ is located in the center of the panel for ease of installation. After the coax cable has been routed and the "F" connectors attached to the coax cable, simply screw the "F" connectors to the Master Controller and the Point Pad™. The cable and connectors are available either through ACR Electronics, your local Radio Shack or other sources of electronic hardware.

Additional Point Pads™ (up to three (3) Pads) may be used with one (1) Master Controller. A standard "T" connector or RG-59 television type "splitter" is used for each additional Point Pad™ (*see Figure 2*). Limit the total length of all coax cable used to 300 feet.

The URP-102 Point Pad™ is backwards compatible with all RCL-100/50 Searchlights and with the URC-101 Master Controller.

**NOTE:** The URP-102 Point Pad™ is not recommended for use with the first generation URC-100 Master Controllers.

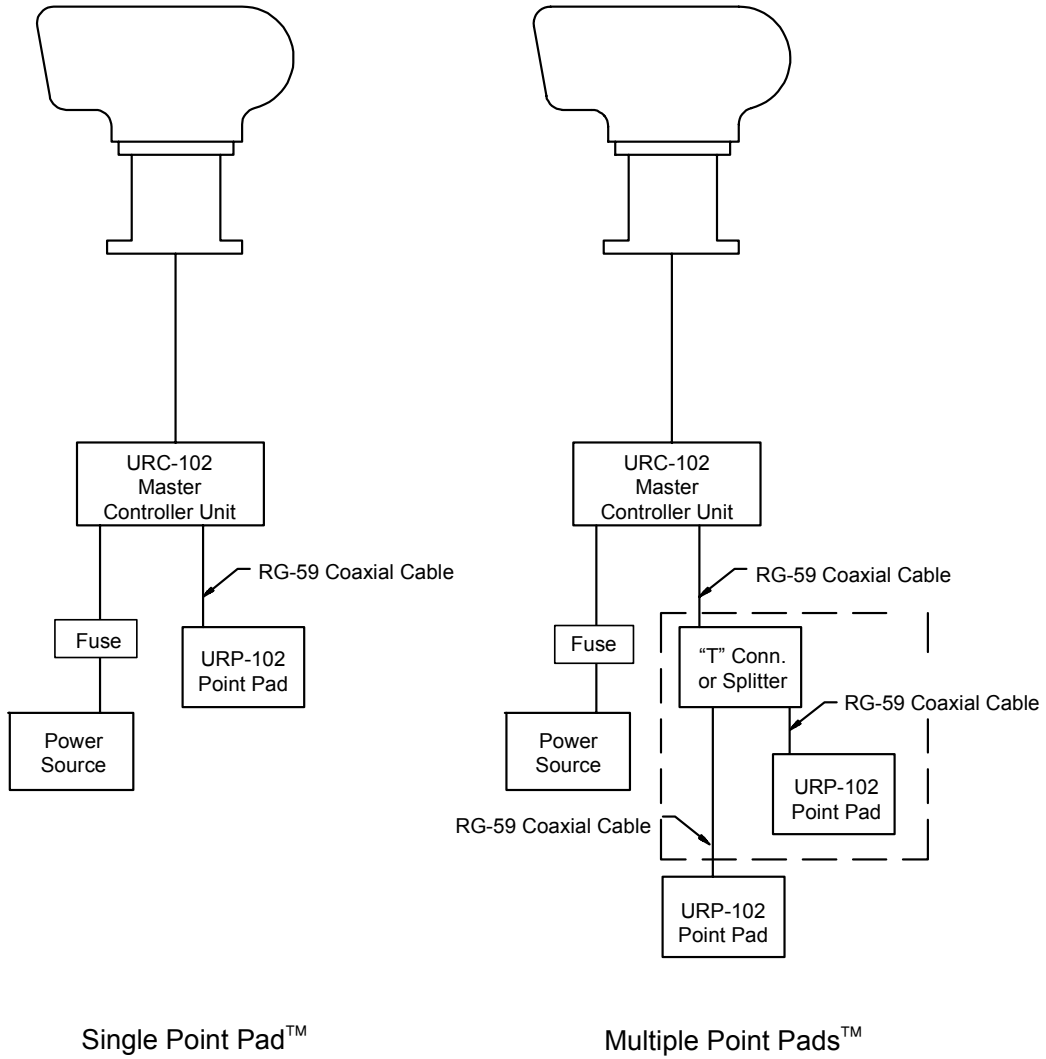

*FIGURE 2: POINT PAD™ CONNECTION BLOCK DIAGRAM*

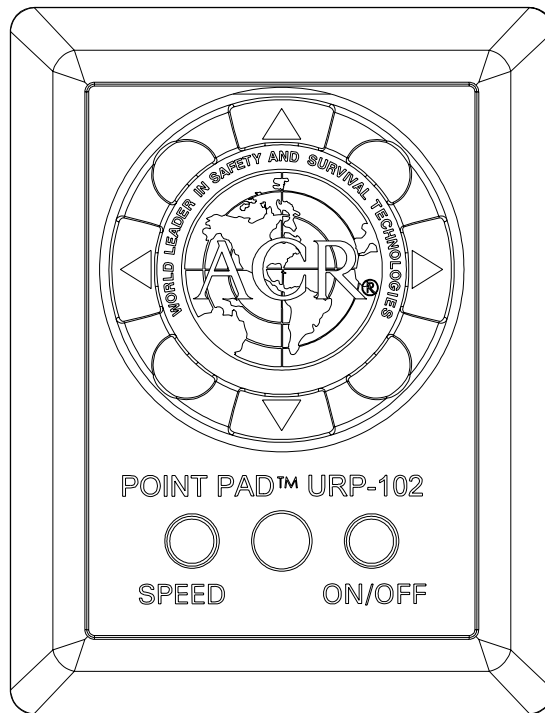

### **URP-102 Point Pad Functions**

- Press the ON/OFF button to turn the lights ON or OFF.
- Press the SPEED button to toggle between High and Low rotation speeds.
- Press the Right or Left Arrows to rotate the Searchlight in that direction.
- Press the Up or Down Arrows to raise or lower the Searchlight-beam.
- To activate the XRCiZ feature, press and hold the ON/OFF button for greater than 5 seconds. The Green LED indicates XRCiZ feature is enabled.
- To deactivate the XRCiZ feature, Press and hold the ON/OFF button for greater than 5 seconds. The Red LED indicates XRCiZ feature is disabled.
- An LED blinking Red / Green indicates that the XRCiZ feature is now “exercising” the Searchlight.

**NOTE:** XRCiZ Feature is only available when paired with a URC-102 Master Controller.

*FIGURE 3: URP-102 POINT PAD™ FUNCTIONS*

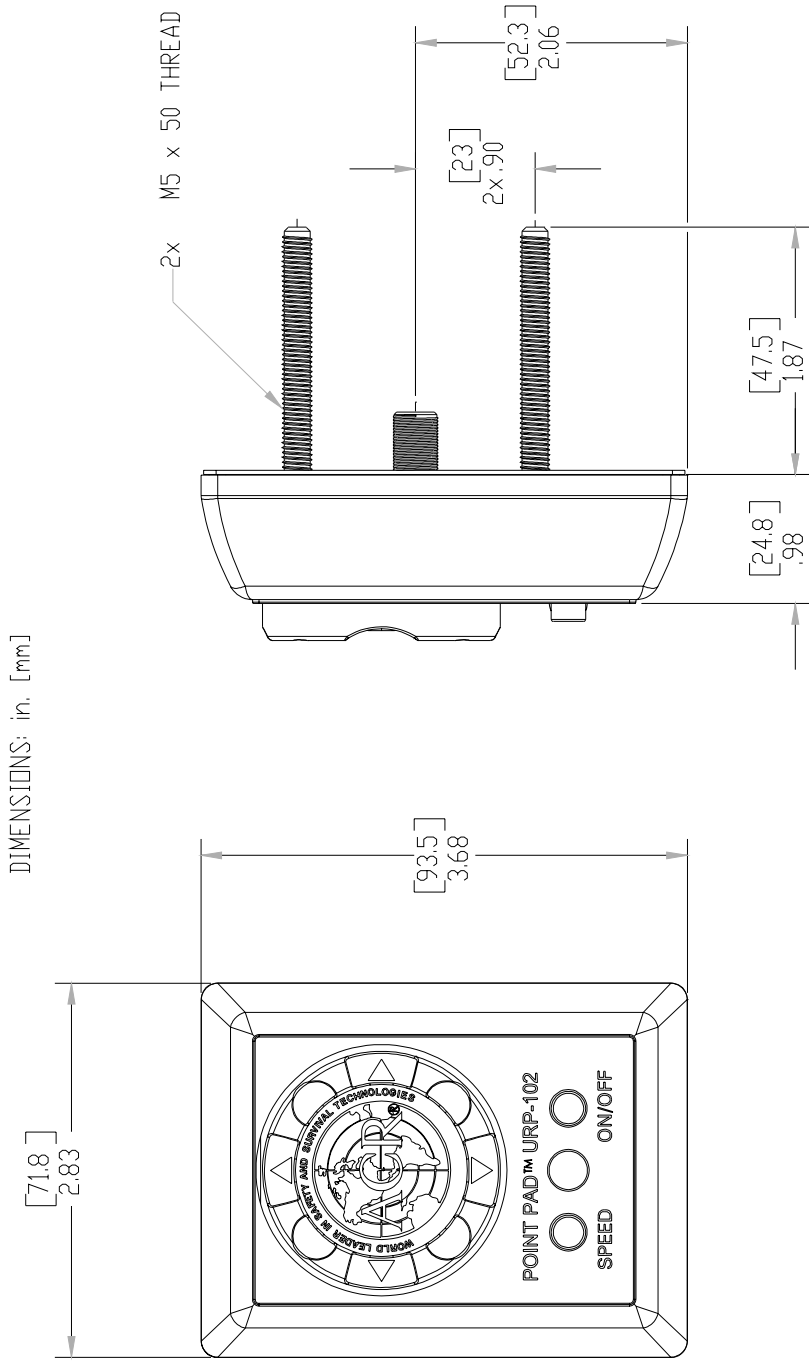
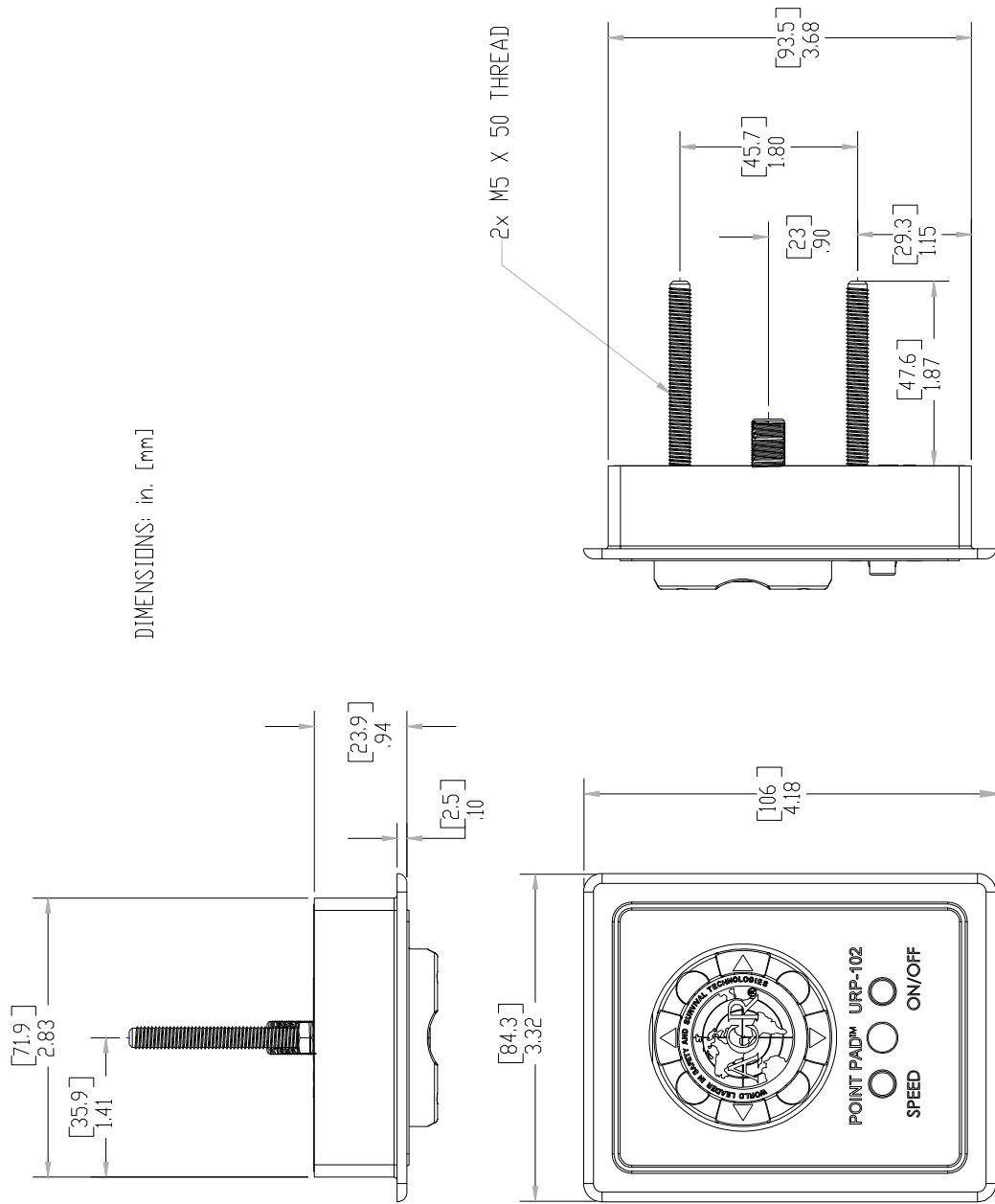

FIGURE 4: URP-102 POINT PAD™ SURFACE MOUNT CASE





DIMENSIONS: in. [mm]

FIGURE 5: URP-102 POINT PAD™ FLUSH MOUNT CASE

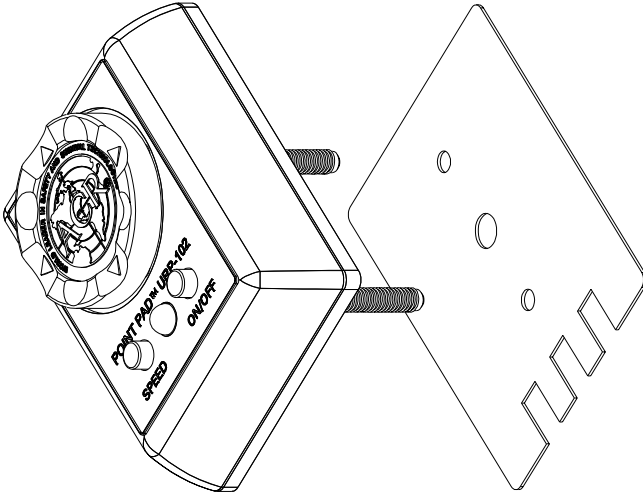
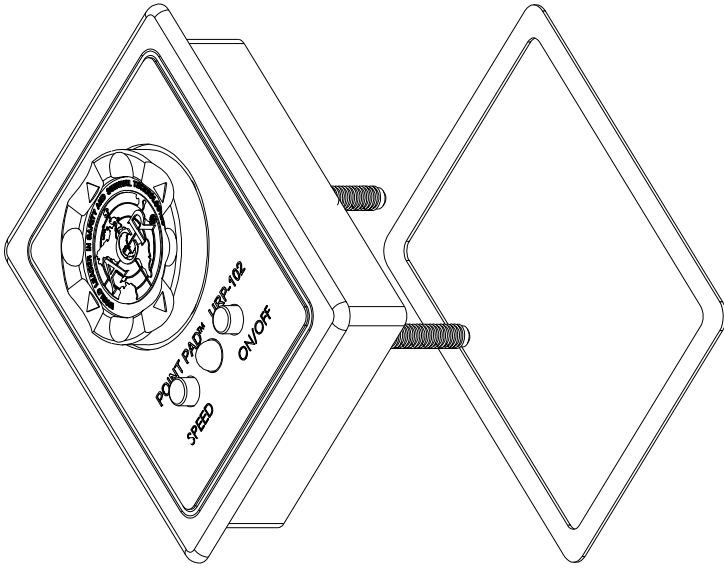

FIGURE 6: URP-102 POINT PAD™  
Surface Mount Case with gasket and Flush Mount Case with gasket

## 6.0 URC-102 MASTER CONTROLLER

### Mounting

The Master Controller can be mounted in any position near the Searchlight that is protected from the weather. Check in advance that the coax cable from the Point Pad™ and the wiring harness from the Searchlight can be routed to this location. Mount the Master controller with the wires and coax facing down. Use an appropriate fastener for your mounting location. Use a sealant in fastener holes to prevent moisture intrusion.

### General Wiring Scheme

The RCL-100 has a unique wiring scheme. Special attention must be paid to the following chart. The Master Controller is supplied with an in-line fuseholder on the Orange power lead. Use only 15 amp fuses in this fuseholder. See Figure 9 for the Master Controller wiring diagram.

**NOTE:** Failure to follow this arrangement may damage components.

Master Controller Wire	Searchlight Cable Wire	Power Source Lead	Function
Orange		+12 VDC or +24 VDC**	Power
Blue		Ground	Ground
Yellow	Yellow		Lamp Power
Green	Green		Lamp Ground
Red	Red		Up
White	White		Down
Black	Black		Right
Brown	Brown		Left

Table 1

**\*\* NOTE:** This wire **MUST** be fused with a 15 amp fuse in the Master Controller's in-line fuseholder.

### Wiring to Searchlight

The RCL-100 Searchlight is supplied with a 15 foot integral wire harness. This wire harness is cut to this length specifically to allow for a voltage drop. Shortening the harness will decrease the life of the bulbs. Any extra length of wire harness should be loosely coiled in a convenient place. For best performance, the controller should be attached to the end of the 15' Searchlight wire harness. If you must lengthen the wire harness, use heavy duty wire to minimize the voltage drop. This is especially important for the **YELLOW** lamp power and **GREEN** lamp ground wires.

Following the wiring scheme shown in Table 1 use the supplied butt connectors to connect the Master Controller to the Searchlight.

### Wiring to Point Pad™

The RG-59 Coax cable is supplied without the “F” connectors attached for ease of routing. After the coax has been routed, strip the insulation and crimp the “F” connectors in place. Screw the “F” connectors to the Master Controller and the Point Pad™.

## Wiring to Power Supply

The power source must be a fused 12 VDC, 10-amp supply or 24 VDC, 5-amp supply. Following the wiring scheme in Table 1, use the supplied butt connectors to connect the Master controller to the Power Source. Refer to Table 2 for proper wire size for connection of the input power lines.

**NOTE:** As per the wiring scheme, the **ORANGE** wire is connected to the Positive terminal and the **BLUE** wire is connected to the Negative terminal of the power source.

**NOTE:** Observe polarities when attaching wires!

Wire Size	Maximum Cable Length	
	12v System	24v System
#8 AWG	25 ft.	100 ft.
#10 AWG	15 ft.	60 ft.
#12 AWG	10 ft.	40 ft.

Table 2

## Function

The URC-102 Master Controller is designed to perform up to six different duties on searchlights, winches, and other electrical devices. The Master Controller provides optimum voltage to ensure brightest performance and long lamp life, regardless of boat system voltage fluctuations. The Master Controller is compatible with devices requiring 12 VDC or 24 VDC operation.

The URC-102 Master Controller has the unique XRCiZ feature. The XRCiZ feature routinely operates all moving parts in the Searchlight to keep the motors and drive mechanism freely running. Once activated, and every 30 days thereafter, the XRCiZ feature wakes up and operates the Searchlight. The Searchlight will rotate 360° in both directions and the parabolic reflectors will move to the full up and down positions. This feature keeps the Searchlight in peak working order when not in service for long periods of time.

To activate the XRCiZ feature, press and hold the Point Pad™ ON/OFF button for greater than 5 seconds. The Green LED on the URC-102 Point Pad™ indicates that the XRCiZ feature is enabled. While enabled, The XRCiZ feature can be started outside of its 30-day cycle by pressing and holding the Speed button on the Point Pad™ for greater than 5 seconds.

While the XRCiZ feature is operating the Searchlight, pressing any Point Pad™ button will stop the current cycle and leave the Searchlight to follow any additional commands.

To deactivate the XRCiZ feature, press and hold the Point Pad™ ON/OFF button for greater than 5 seconds. The Red LED on the URC-102 Point Pad™ indicates that the XRCiZ feature is disabled.

**NOTE:** LED feedback is not available when using RCL-100 or URC-101 Point Pads™.

**NOTE:** The Searchlight should not be covered while the XRCiZ feature is enabled.

The URC-102 Master Controller provides optimum voltage to ensure the brightest Searchlight performance and long bulb life. Also to extend lamp life, the Master Controller has a timed lamp power up feature. The Searchlight lamps reach full intensity within 2 seconds.

The URC-102 Master Controller has a Searchlight motor timeout feature. If a Point Pad™ rotation switch (right or left) is continuously engaged for more than 50 seconds, the Master Controller will interrupt the operation until the Point Pad™ switch is disengaged. This feature will save the Searchlight motor from burnout due to accidental activation. The elevation motor has similar features which will timeout in approximately 20 seconds.

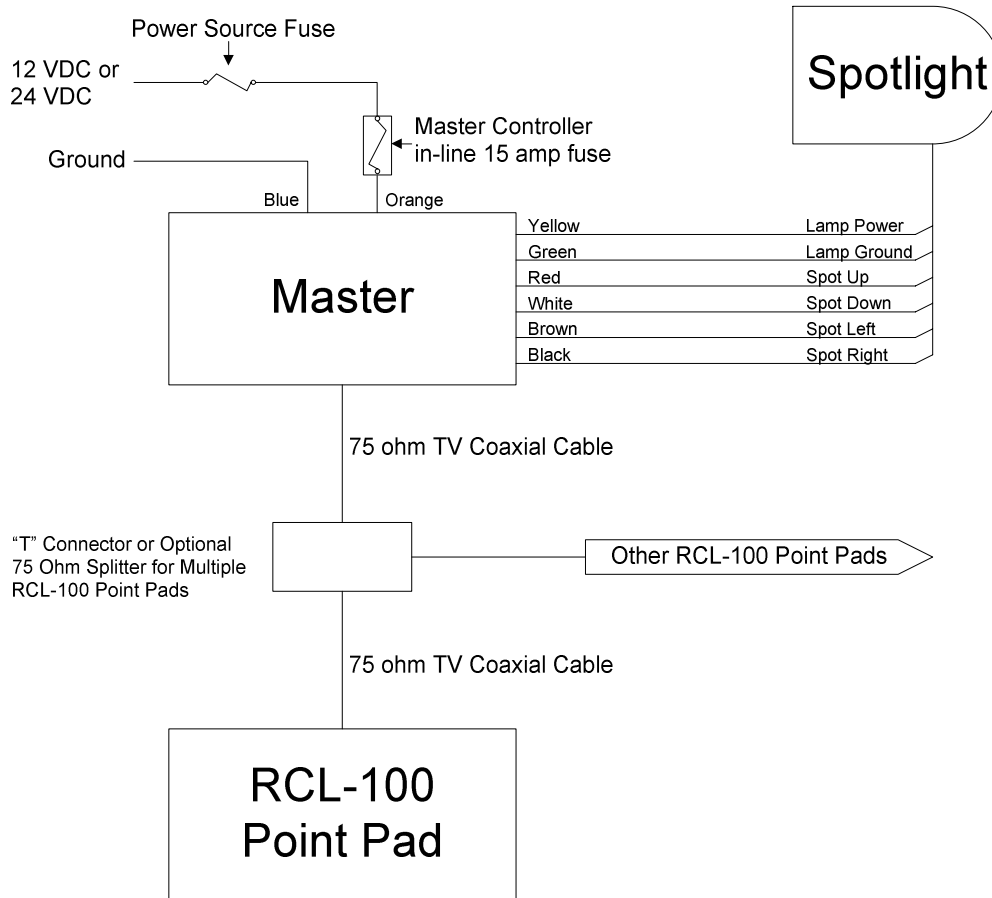

*Note: Wiring must be in accordance with this diagram. Improper wiring will damage components.*

**FIGURE 7: URC-102 MASTER CONTROLLER WIRING DIAGRAM**

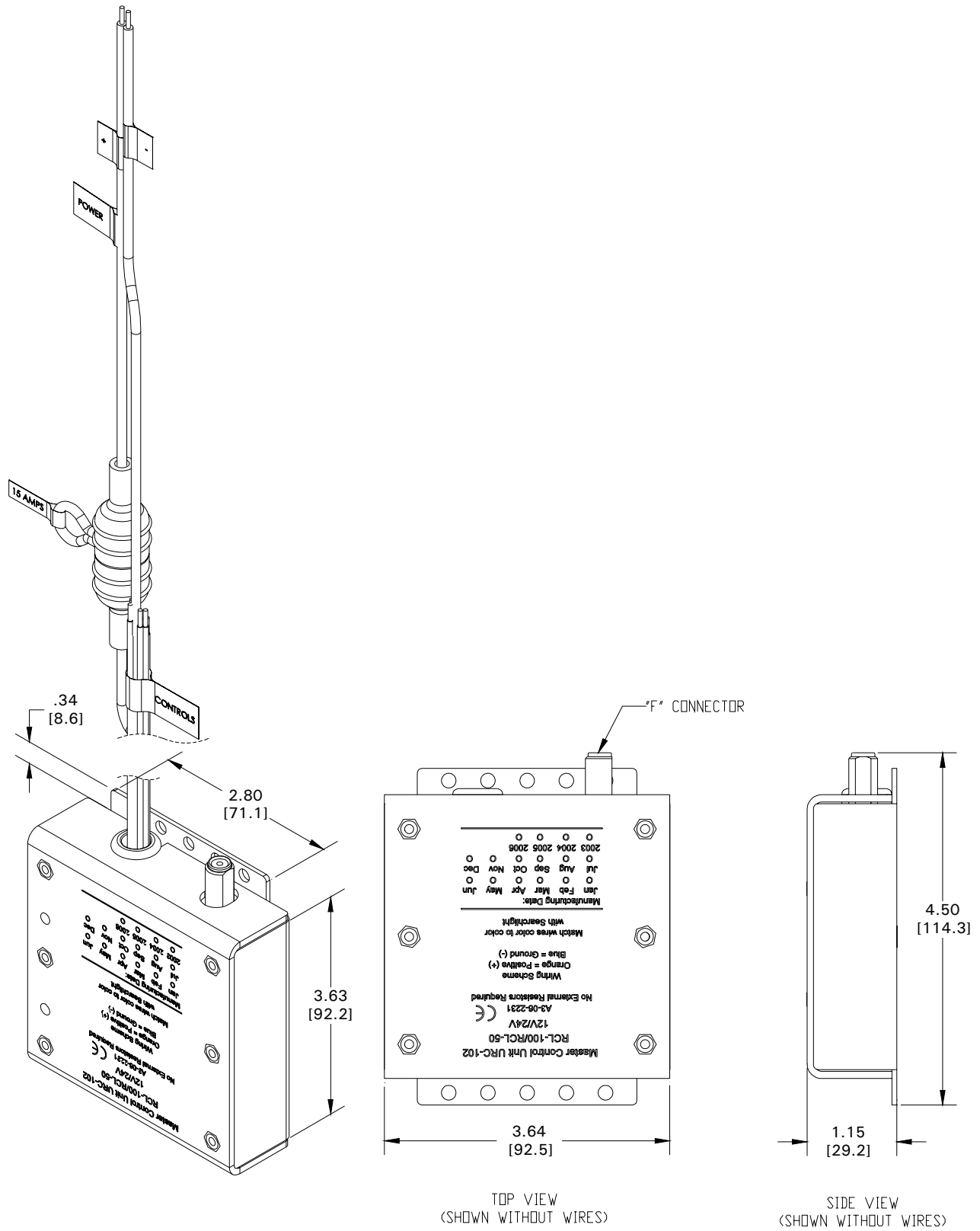

Figure 8: URC-102 MASTER CONTROLLER

## 7.0 RCL-100D SPECIFICATIONS (with URC-102 Controller)

<u>Specifications</u>	<u>12V UNIT</u>	<u>24V UNIT</u>
Mirror Diameter	4" x 2-3/4"	Same
Rated Voltage (Volt)	12 to 16 VDC	24 to 31 VDC
Rated Current (A)	10	5
Applicable Lamp	55W Halogen Lamp x 2 (Base-G6.35) JCD12V-55WDX	55W Halogen Lamp x 2 (Base-G6.35) JCD24V-55WDX
Peak Beam Candle Power (candela)	200,000	160,000
Beam Spread (degrees)		
Horizontal	7°	Same
Vertical	5°	Same
Elevation Angle (degrees)		
Up	9°	Same
Down	17°	Same
Turning Angle (degrees)	360°	Same
Elevation Speed	4° per second	Same
Turning Speed		
Fast	28° per second	Same
Slow	15° per second	Same
Weight	7.15 pounds	Same
Interconnect Cable	15 feet	Same

*Note: All specifications are nominal values*

# ACR/RCL-100D

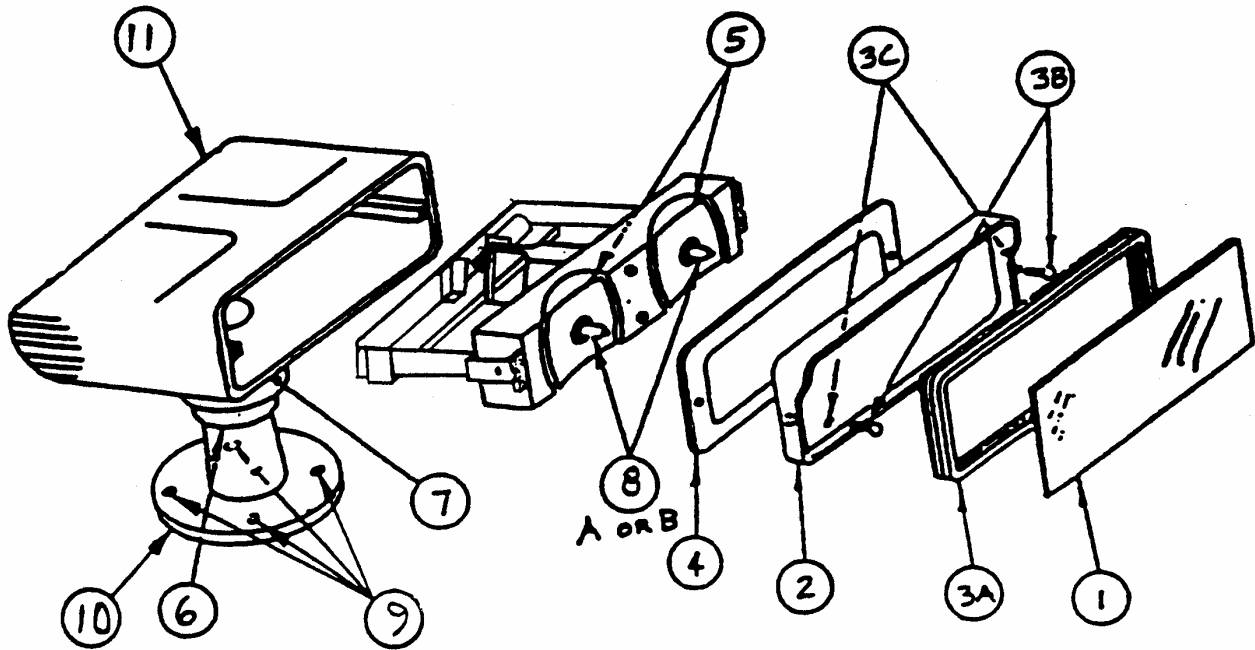

<u>ITEM NO.</u>	<u>DESCRIPTION</u>	<u>QTY</u>	<u>PART NUMBER</u>
1	Front Glass	1	HRMK 1300
2	Front Frame	1	HRMK 1101
3A	Window Weather Strip	1	HRMK 1201
3B	Screw M4x18	2	HRMK 1600
3C	Washer M408	2	HRMK 9301
4	Gasket of front frame	1	HRMK 1200
5	10 cm reflector	2	HRMK 1301
6	Protection Cover	1	HRMK 2102
7	O-Ring #594	1	HRMK 2202
8A	55W quartz halogen Bulb (12V)	2	A1-14-0080-1
or 8B	55W quartz halogen Bulb (24V)	2	A1-14-0080-2
9	Shoulder Washer	4	A1-05-0660-24
10	Base Housing	1	HRMK2103
11	Head Housing	1	HRMK2101

FIGURE 9: SEARCHLIGHT USER REPLACEABLE PARTS



## 8.0 BULB REPLACEMENT

Two 55W, quartz-halogen bulbs are provided with your **RCL-100D**. If they should need replacement, they must be ordered through ACR Electronics, by P/N A1-14-0080-1 (12V units) or A1-14-0080-2 (24V units).

To replace the lamps:

1. Disconnect unit from power source and allow bulbs to cool.
2. Remove two screws holding the front flange and glass in place.
3. To remove the old lamp bulbs, grasp base of the lamp and pull straight out. **DO NOT TOUCH GLASS PARABOLIC REFLECTORS WITH FINGERS OR TOOLS!**
4. Install the new lamp bulb using a soft clean cloth to avoid touching the bulb with your fingers. Insert the lamp bulb pins into socket and press firmly in place.

**NOTE: If the Lamp Bulb or Reflectors are accidentally touched, carefully clean with a soft rag and alcohol before continuing.**

5. Replace the front flange and glass and install the two retaining screws. Be sure the neoprene gasket is securely in place.
6. Reconnect the unit to the power source.

## 9.0 RCL-100D SEARCHLIGHT COMPONENTS

**PRODUCT NO. 1930.3** - RCL-100D 12 V Searchlight Installation Kit includes:

<u>Description</u>	<u>Quantity</u>	<u>ACR Part Number</u>
Searchlight, RCL-100D, 12 V	1	A3-06-1106-3
Kit, Nylon Washers (4)	1	A3-06-1940
Connector, "F"	2	A1-03-0220
Cable, Coaxial	15'	A2-07-0002-6
Master Controller, URC-102	1	A3-06-2231
Connector, "In-Line"	8	A1-03-0222
Point Pad™, URP-102 with Surface Mount Case	1	A3-06-2230
Case, Flush Mount	1	A1-18-1875-2
Gasket, Surface Mount	1	A1-25-0140-1
Gasket, Flush Mount	1	A1-25-0140-2
U Clamp	2	A1-17-1366
Nuts, Nylon-lock	2	A1-05-0776
Washers	2	A1-05-0777
Warranty Card	1	A1-20-1019
Product Support Manual	1	Y1-03-0138
Mounting Templates	1	Y1-03-0138-1
Troubleshooting and Maintenance Guide Instructions	1	Y1-03-0137

**PRODUCT NO. 1931.3** - RCL-100D 24 V Searchlight Installation Kit includes:

<u>Description</u>	<u>Quantity</u>	<u>ACR Part Number</u>
Searchlight, RCL-100D, 24 V	1	A3-06-1106-4
Kit, Nylon Washers (4)	1	A3-06-1940
Connector, "F"	2	A1-03-0220
Cable, Coaxial	15'	A2-07-0002-6
Master Controller, URC-102	1	A3-06-2231
Connector, "In-Line"	8	A1-03-0222
Point Pad™, URP-102 with Surface Mount Case	1	A3-06-2230
Case, Flush Mount	1	A1-18-1875-2
Gasket, Surface Mount	1	A1-25-0140-1
Gasket, Flush Mount	1	A1-25-0140-2
U Clamp	2	A1-17-1366
Nuts, Nylon-lock	2	A1-05-0776
Washers	2	A1-05-0777
Warranty Card	1	A1-20-1019
Product Support Manual	1	Y1-03-0138
Mounting Templates	1	Y1-03-0138-1
Troubleshooting and Maintenance Guide Instructions	1	Y1-06-0137

## 10.0 REMOTE CONTROL SYSTEM COMPONENTS

**PRODUCT NO. 1927.3** - URC-102 Master Controller Installation Kit includes:

<u>Description</u>	<u>Quantity</u>	<u>ACR Part Number</u>
Master Controller, URC-102	1	A3-06-2231
Connector, "In-Line"	8	A1-03-0222
Instruction Sheet, Master Controller	1	Y1-06-0178

**PRODUCT NO. 1928.3** - URP-102 Point Pad™ Installation Kit includes:

<u>Description</u>	<u>Quantity</u>	<u>ACR Part Number</u>
Point Pad™, URP-102 with Surface Mount Case	1	A3-06-2230
Case, Flush Mount	1	A1-18-1875-2
Gasket, Surface Mount	1	A1-25-0140-1
Gasket, Flush Mount	1	A1-25-0140-2
U Clamp	2	A1-17-1366
Nuts, Nylon-lock	2	A1-05-0776
Washers	2	A1-05-0777

Adapter Plate, Flush mount	1	A1-18-1871
Adapter Plate, Surface mount	1	A1-18-1892
Instruction Sheet, Point Pad™	1	Y1-06-0179
Mounting Templates	1	Y1-03-0138-1

**PRODUCT NO. 1929.1** - Wiring Kit RCL-50 / 100 Series Searchlights Includes:

<u>Description</u>	<u>Quantity</u>	<u>ACR Part Number</u>
Connector, "F"	2	A1-03-0220
Cable, Coaxial	15'	A2-07-0002-6

**PRODUCT NO. 9282.3** – URP-102 Point Pad™ Secondary Station Installation Kit includes:

<u>Description</u>	<u>Quantity</u>	<u>ACR Part Number</u>
Point Pad™, URP-102 with Surface Mount Case	1	A3-06-2230
Case, Flush Mount	1	A1-18-1875-2
Gasket, Surface Mount	1	A1-25-0140-1
Gasket, Flush Mount	1	A1-25-0140-2
U Clamp	2	A1-17-1366
Nuts, Nylon-lock	2	A1-05-0776
Washers	2	A1-05-0777
Adapter Plate, Flush mount	1	A1-18-1871
Adapter Plate, Surface mount	1	A1-18-1892
Splitter, 2-Way Signal	1	A1-03-0235
Screw, #6	2	A1-05-0614
Cable, Coaxial	15'	A2-07-0002-6
Connector, "F"	4	A1-03-0220
Instruction Sheet, Point Pad™	1	Y1-06-0179
Mounting Templates	1	Y1-03-0138-1

**PRODUCT NO. 9283.3 – Remote Control Installation Kit Includes:**

<b><u>Description</u></b>	<b><u>Quantity</u></b>	<b><u>ACR Part Number</u></b>
Master Controller, URC-102	1	A3-06-2231
Connector, "In-Line"	8	A1-03-0222
Point Pad™, URP-102 with Surface Mount Case	1	A3-06-2230
Case, Flush Mount	1	A1-18-1875-2
Gasket, Surface Mount	1	A1-25-0140-1
Gasket, Flush Mount	1	A1-25-0140-2
U Clamp	2	A1-17-1366
Nuts, Nylon-lock	2	A1-05-0776
Washers	2	A1-05-0777
Adapter Plate, Flush mount	1	A1-18-1871
Adapter Plate, Surface mount	1	A1-18-1892
Cable, Coaxial	15'	A2-07-0002-6
Connector, "F"	2	A1-03-0220
Instruction Sheet, Master Controller	1	Y1-06-0178
Instruction Sheet, Point Pad™	1	Y1-06-0179
Mounting Templates	1	Y1-03-0138-1