

STAYING TRUE TO YOUR COURSE.

Accu-Steer, Inc.

HIGH-PERFORMANCE HYDRAULIC CONTROL OF STEERING SYSTEMS

Defining
Reliability
through form and function.

(Each unit is completely tested after assembly)

Dedicated to quality high-performance
hydraulic control of steering systems for
yachts and commercial vessels.

Instruction Manual
LA17

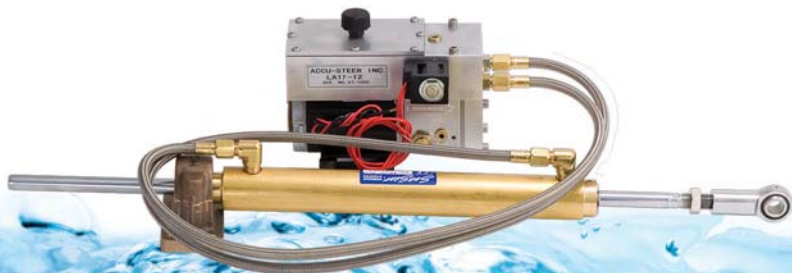

HYDRAULIC LINEAR ACTUATOR

LA17

TABLE OF CONTENTS

1. GENERAL INFORMATION	p. 01
2. TECHNICAL SPECIFICATIONS and APPLICATION	p. 02
3. DESCRIPTION	p. 03
3.1 General	
3.2 Pump Unit (HRP17)	
3.3 Reservoir/Bypass Assembly	
3.4 Steering Cylinder	
4. INSTALLATION	p. 05
4.1 Mechanical	
4.2 Hydraulic	
4.3 Electrical	
5. NOTES	p. 07
6. DRAWINGS	p. 08
6.1 LA17 – Assembly Schematic	
6.2 LA17 – System Connection Schematic	

1. GENERAL INFORMATION

The **Accu-Steer LA17** unit is a hydraulic linear actuator designed to interface an autopilot system with a mechanical steering systems such as wire, cable or chain drives. A hydraulic linear actuator consists of a hydraulic drive unit (containing a pump unit, bypass valve and reservoir assembly), a steering cylinder and the interconnecting hoses.

One end of the cylinder is fixed and the other end is connected to a tiller arm or the mechanical quadrant, which is connected to a rudder shaft. With this connection to a tiller arm the linear movement of the cylinder is changed to rotary movement, which turns the rudder and steers the vessel.

During normal mechanical steering, the hydraulic steering cylinder strokes to port and starboard as the vessel is steered manually. The oil in both sides of the cylinder flows back and forth through a normally open bypass valve located in the linear actuator drive unit. The steering cylinder is connected to the drive assembly with two hoses (port and starboard). When the autopilot is switched into the operating mode, the bypass valve is electrically closed. The autopilot then drives the reversing hydraulic pump which in turn operates the steering cylinder. **See section 3 of this manual for a more in depth description.**

When the autopilot is operating, the cylinder will be turning the rudder. The mechanical steering will be back-driven during this time. The vessel's steering wheel will be turning as the autopilot makes corrections.

The **Accu-Steer HRP17** is the reversing pump unit used in the **LA17** linear actuator. The output flow rate of the pumpset determines the speed of the steering cylinder. The **HRP17** pump outputs 1.6 cu in/sec or 26.2 cc/sec.

The **BA175 X 12** is a balanced steering cylinder, which means the volume of oil on both sides of the cylinder is equal. The volume of this steering cylinder is 23.5 cu in (385 cc) of oil.

2. TECHNICAL SPECIFICATIONS and APPLICATION

Model Number	LA17-12	LA17-24
Voltage	12 VDC	24 VDC
Output/Sec	1.6 cu in/sec	1.6 cu in/sec
Average Motor Amp	4-8	3-5
Solenoid Valve Amp	1.5 AMPS	.75 AMP
Weight	15 lbs (7 kgs)	15 lbs (7 kgs)

The output of the hydraulic reversing pump is 1.6 cu in/sec. The volume of the steering cylinder is approximately 23.5 cu in (385 cubic centimeters). The rudder speed will be approximately 14.7 seconds hard over to hard over (HOH).

The rudder speed, hard over to hard over (HOH), is determined by dividing the volume (cu in) of the cylinder by the output of the pumpset (cu in/sec).

The steering cylinder is capable of approximately 1,045 lbs of thrust based on an output of 500 psi from the pump. The force or torque applied to the rudder through the rudder shaft is dependent of the distance between the center of the rudder shaft and the position of the tiller bolt.

Figure 2 CYLINDER SCHEMATIC

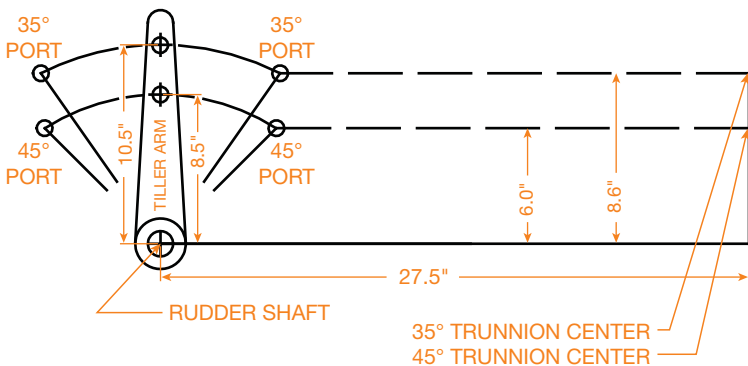

Distance (rudder shaft to tiller bolt): 7" = 7,315 in/lb; 8" = 8,360 in/lb; 9" = 9,405 in/lb; 10" = 10,450 in/lb. *The torque required to turn the rudder can be calculated or obtained from the vessel's builder.*

3. DESCRIPTION OF OPERATION

3.1 GENERAL

The Accu-Steer LA17 is a complete linear actuator drive unit. It consists of a reversing gerotor gear pump, hydraulic lock valves, suction make-up check valves, a valve housing manifold, an electric permanent magnet motor, an electric solenoid bypass valve and an oil reservoir.

Figure 3.1 HYDRAULIC SCHEMATIC

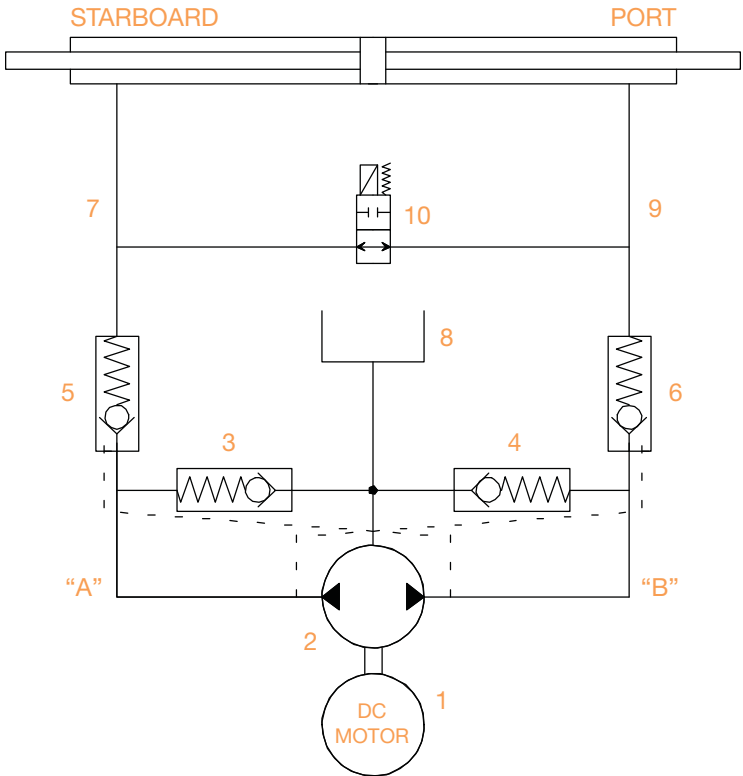

During normal mechanical steering the cylinder is stroked both ways as driven by the mechanical steering system. The oil in the cylinder is bypass through the normally open (NO) solenoid valve (10). When the autopilot becomes active it closes the solenoid valve (clutch/bypass or switched power output). The autopilot then drives the hydraulic reversing pump (2).

The HRP (Hydraulic Reversing Pumpset) operates as follows:

As the motor (1) rotates CCW, oil from the gear pump (2) is pumped towards output “A”. This oil passes through the check valve (5) and goes to the line output (7). The oil pushes the cylinder in the port direction. The pressure at output “A” ensures the check valve (3) stays closed and manually opens check valve (6). Opening check valve (6) allows the returning oil from the steering cylinder to flow back to the pump. If the pressure at the pump suction “B” is less than the weight of the oil in the reservoir (8) then the oil in the reservoir will pass by the check valve (4). This prevents cavitation due to any air that may be in the steering line. When the pump stops turning all spring-loaded check valves return to the normally closed position. When the motor (1) rotates (CW) the reverse movement of the oil and valves takes place.

3.2 PUMP UNIT (HRP17)

The electric motor has the following features:

- *Ignition protected (UL 1500 and SAE-1171)*
- *Ball bearing shaft supports both ends*
- *Cushioned foot mounts for quiet operation*
- *Opposite end shaft mount for tachometer/encoder*

The valve block is an aluminum block, precision machined to house the valves, direct the oil and serve as the endplate for the gear pump. The output check valves are part of what is called a lockvalve assembly.

The lockvalve assembly consists of two output check valves and a lockvalve spool. In the non-running position the spring operated check valves remain closed, isolating the pump from the steering system. The spring action of the check valves holds the lockvalve spool in the mid-closed position.

3.3 RESERVOIR/BYPASS ASSEMBLY

The reservoir unit is machined out of solid aluminum and provides approximately 11.5 cu in of oil for oil make-up. The solenoid bypass valve is located in the same aluminum housing. It is a normally open valve and switches to the closed position when energized by the autopilot. The valve returns to the normally open position when the autopilot is switched into the standby mode or if there was a loss of power to the autopilot.

Oil passages are machined as large as possible to minimize any restrictions which may effect manual steering.

3.4 STEERING CYLINDER

The brass steering cylinder is engineered and manufactured for heavy duty marine usage and is suitable for commercial and pleasure boat applications. The cylinder has a 1-1/2" bore and a 9" stroke. The trunnion mount (fixed end) and the ball joint allow for about 10 degrees of articulation. The cylinder is shipped full of oil and is also equipped with bleed fittings.

4. INSTALLATION

4.1 MECHANICAL

The linear actuator drive unit must be mounted on a horizontal shelf or bracket with a solid foundation. The unit can be bolted or screwed down with the motor feet and the foot bracket. The mounting brackets are fitted with anti-vibration mounts to maintain the quiet operation of the pumpset. The drive unit should be mounted above the steering cylinder if possible to assist in the system bleeding.

Proper cylinder installation is the key to the successful operation of the linear actuator. An incorrectly installed cylinder is subject to rapid seal and bearing wear and non-repairable damage. Minimum side loading of the cylinder rod and maximum cylinder performance can be achieved as follows.

An imaginary line drawn through the tiller arm hole at both hard over positions will create the cylinder center line, **see Figure 4.1**. The distance between X and Y must be less than 9" so that the cylinder doesn't act as an end stop for the rudder.

Figure 4.1 CYLINDER SCHEMATIC

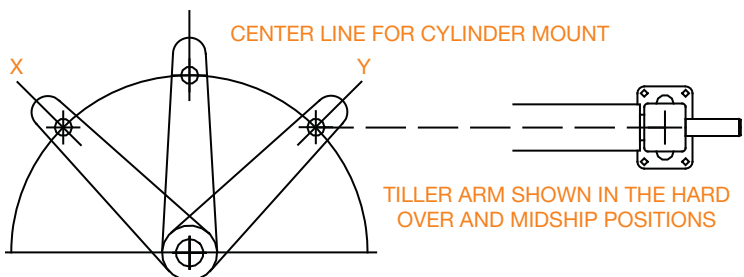

In a new installation, mechanical stops can be installed after the cylinder. For retro-fit applications, **use Figure 4.1** as a reference to ensure the ends of the cylinder travel are outside the stops. Mount cylinder with the fittings in the up direction.

4.2 HYDRAULIC

The unit is shipped full of oil with a sealed plug in the top of the reservoir cover. A vented breather cap is supplied with the unit. The vented cap must be installed in place of the plug after the drive unit has been mounted. The oil in the **LA17** is standard hydraulic oil (ISO-32).

If the hydraulic lines are removed during installation, be sure to cap them to minimize the loss of oil. Located on the top of the valve/reservoir block is a small bleed fitting. This fitting can be used add oil to the port and starboard lines or bleed air from the system. If the cylinder is mounted properly, the cylinder can be manually stroked and the air will collect at the bleed fitting. Be sure to re-install this plug before using the **LA17** as it is part of the steering line.

The oil reservoir should be maintained at least 3/4 full. During bleeding and filling this level should be maintained.

It is not critical to identify which of the steering lines is port or starboard as most new autopilots will determine the pump direction and program the drive outputs to suit. For older autopilots the motor leads can be reversed to change the pumps direction.

4.3 ELECTRICAL

The motor is a permanent magnet style motor, ignition protected, built to conform to UL-1500 and SAE-1171 standards. Two leads connect to the autopilot pump driver junction box (processor), the direction of the pumpset can be reversed by simply reversing the polarity of these two leads.

The solenoid valve is connected to the autopilot junction box. It is usually referred to as clutch/bypass or switched power. The polarity of the solenoid valve does not matter.

To test the operation of the **LA17** pumpset, touch the two leads from the motor to the supply voltage (12 VDC or 24 VDC) to jog the motor in one direction and then reverse the leads to jog the pumpset in the other direction. **Do not to perform this operation where any combustible fumes exist.**

6. DRAWINGS

6.1 LA17 ASSEMBLY SCHEMATIC

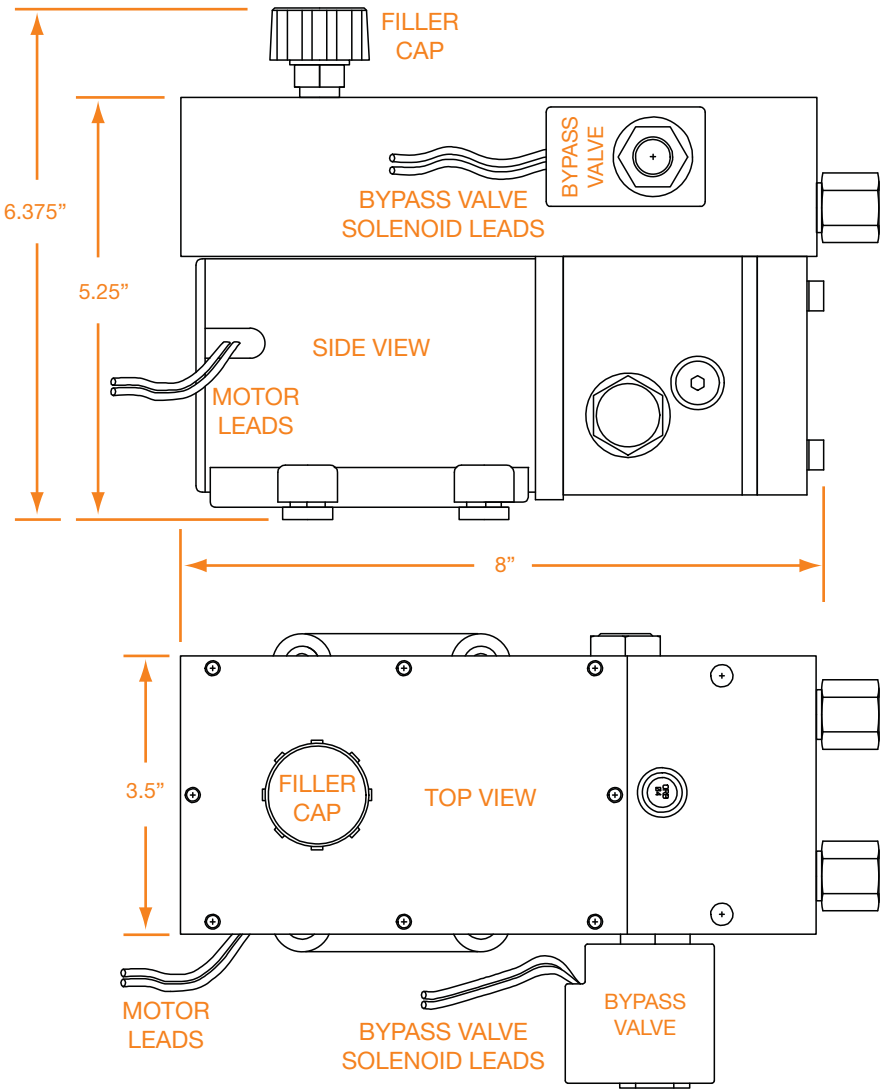

6.2 LA17 SYSTEM CONNECTION SCHEMATIC

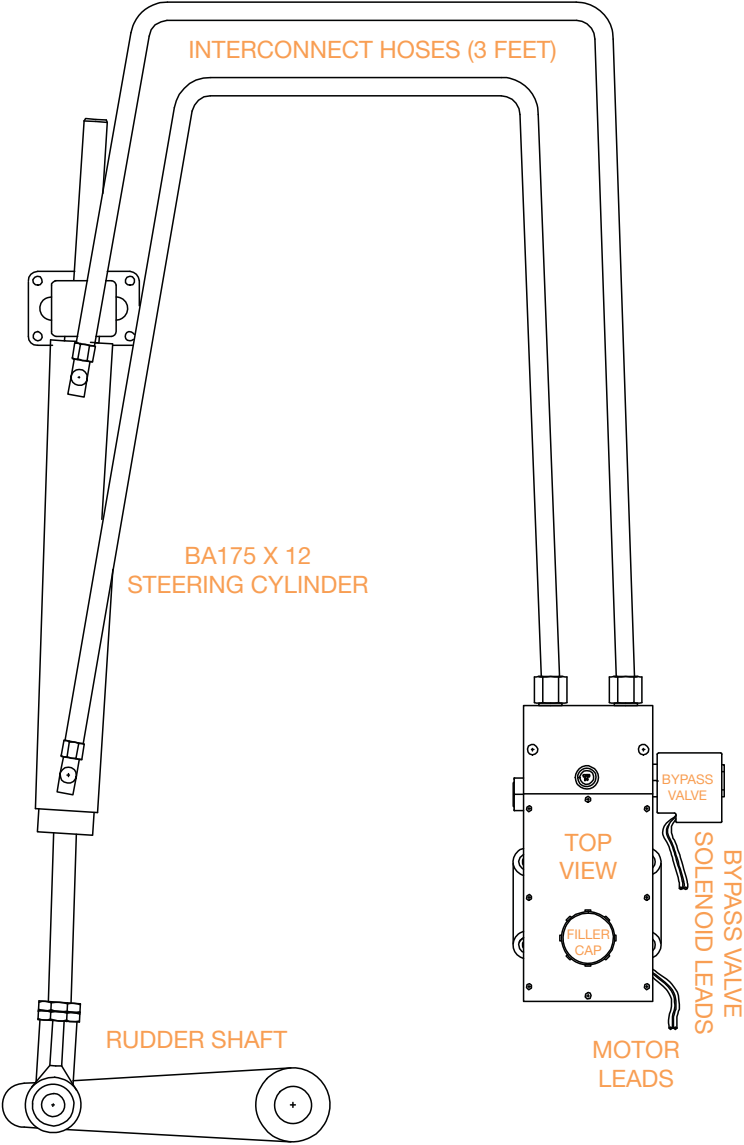



STAYING TRUE TO YOUR COURSE.

Accu-Steer, Inc.

**Accu-Steer, Inc. • Marina Square
704 Coho Way • Bellingham, WA 98225**

(360) 733-4565, telephone • (360) 733-4575, fax
cs@Accu-Steer.com • www.Accu-Steer.com

Instruction Manual
LA17

