

# FURUNO®



*Operator's Guide to  
Marine Radar*

# Table of Contents

- 1-3) Principles of Radar
- 3-5) Radar System Configurations
- 5-6) Radar Terminology
- 6-8) Radar Controls
- 9) Targeting Birds
- 10-11) Range, Bearing and Position
- 12-14) Advanced Radar Operation
- 15-18) Radar FAQ's
- 19) Additional Resources
- 20) Radar Mark Definitions
- 21) Maintenance



*Boats of all types can benefit from having a Radar onboard for navigation and situational awareness.*

When it comes to safety on the water, no other piece of electronic equipment on your bridge is as important as your Radar. For more than 30 years, Furuno Radars have consistently won the prestigious NMEA (National Marine Electronics Association) award for Best Radar. Whether you are looking for a compact 2.2kW unit or a commercial grade 50kW Radar, Furuno is the single largest source of Radars you can rely on. This book will help you learn about what a Radar is, how it works, and how to get the most from what is perhaps the most important navigation device you will ever own.

## **FURUNO®**

# 1. Principles of Radar

## What is Radar?

Radar is an acronym meaning RAdio Detecting And Ranging. It is a device which measures not only the time it takes for a pulsed signal to be reflected back from an object but also its bearing relative to your position. No other piece of marine electronics can give you as much information about objects around your own ship as Radar.

## Present state of Radar:

Radar was developed during World War II. Today, Radar is available for all classes of vessels including small fishing vessels and pleasure craft. Many pleasure boats may also have a color video sounder (Fish Finder) or navigation device such as a GPS receiver, but the single most important piece of electronics is the Radar. No other gear can give you the ability to spot a vessel coming at you out of the fog, or tell you the location of the inlet to a harbor in the pitch black of night.

For navigational safety, nothing beats Radar. While your chart plotter may show you where everything around you is *supposed to be*, only your Radar can show you where everything *is*, including coastline and navigation aids such as beacons or buoys, as well as uncharted objects such as vessel traffic and other obstructions.

## About Furuno Radars:

The National Marine Electronics Association (NMEA) annually recognizes its member marine electronics manufacturers for superior products. Furuno annually takes home the top award in several categories of marine electronics equipment, and our Radars have won the top prize every year since 1976. Furuno has repeatedly won the coveted NMEA award for Manufacturer of the Year - Support. These awards make it clear that Furuno is the leading manufacturer of Radar in terms of quality, reliability and after-purchase support.

## What Radar Can Do

Radar mainly functions as an anti-collision aid. It also provides information about the whereabouts of neighboring vessels, coastal outlines, etc.

- **Navigate in darkness and fog**

In fog or darkness, you may lose situational awareness around your own ship because of poor or no visibility. With Radar acting as your eyes, however, you have the ability to monitor other ships' movement under these conditions.

- **Collision avoidance**

The guard alarm feature of every Furuno Radar alerts you when targets enter a particular area, or own ship is nearing a danger area. The alarm area can be forward of own ship or a 360-degree circle around the vessel. When Radar targets such as other ships, landmasses or buoys enter the zone, an audible alarm sounds to alert the operator.

- **Assess target movement**

The Echo Trail feature simulates target movement in afterglow. It is useful for assessing the movement of all targets relative to own ship. Some Radars have the capability to show the true movement of targets, providing increased navigational safety.

- **Determine own ships position**

Since Radar sees further than the naked eye, the echoes from islands and landmasses can be used to determine own ships' position. When running near land, you can use peninsulas and other targets whose echoes show distinct contours on the display to determine own ships' position. Distant, tall mountains or bridges may be similarly used provided they are above the horizon

- **Navigate to specific location**

Fishing vessels and pleasure boats use Radar to help them navigate to favorite fishing spots. When navigating to a fishing spot, the forces of wind and current can combine to throw the vessel off its intended course. To remember your location if your ship drifts, use the VRM and EBL to mark range and bearing to nearby islands or peninsulas.

- **Navigate straight to waypoint**

The map-like picture displayed by Radar helps you navigate straight to a waypoint and compliments chart plotter images.

- **Receive Radar beacon (RACON)**

Radar can receive pulsed signals from a Radar beacon to determine own ships position.

- **Fishing operation**

Besides its basic function as an aid to navigation, Radar is also a valuable tool for fishing operations. Purse seiners use it to monitor net shape, observing the echoes from floats attached to the net. It is especially useful in fleet fishing for determining position of vessels, locating fishing grounds and positioning vessels.

Specialty fisherman use Radar to search for sea birds, which may be an indication of the presence of bait fish or their target species. This technique has become easier with the advent of dual-range simultaneous scanning, such as that found in NavNet 3D, where the navigator can use one Radar screen with the gain set for targeting birds, while the other Radar screen is used to navigate. As you can see, for many fishing vessels Radar functions more often as an aid to fishing rather than an aid to navigation.

## How It Works

Did you ever shout at a cliff and hear the echo of your shout? Radar works in a similar manner. Imagine that radio pulses are emitted from the scanner in a certain direction. When the pulse strikes an object such as a ship or island some of the energy returns to the scanner. The direction in which the scanner is pointing when the reflection is received is the direction of the target causing the reflection. Since radio waves travel at a near-constant speed, the time required for the reflected echo to return to the scanner is a measure of the range to the target.

## How Radar determines range

The radio pulse makes a complete round trip, but only half the time of travel is needed to determine the range to the target. This equation shows how range is determined:

$$D = 1/2 \times cT$$

c = Speed of Radio Pulse (3 x 10<sup>8</sup> m/sec)

T = Time between transmission of radio pulse and reception of reflected echo

D = Distance

Both radio waves and light travel at the near-constant speed of 186,000 miles per second; therefore, the Radar can process vast amounts of information in a very short time. Comparatively, Sonar and Fish Finders use ultrasonic waves rather than radio waves. Since the propagation speed of the ultrasonic wave is 1,500 miles per second, signal processing is much slower with these devices than with Radar.

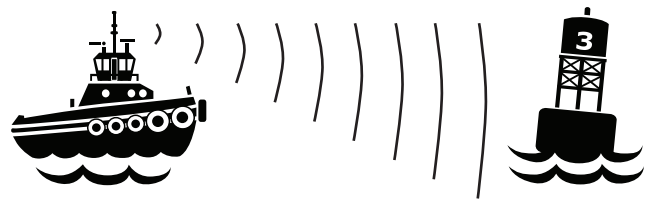

## How Radar determines bearing

Radar determines the range to a target by measuring the amount of time required for a reflected echo to return to the scanner. Bearing to a target is determined by the direction from which a reflected echo returns.

The scanner rotates 360 degrees about its vertical axis, using a special gear. In order to achieve precise bearing resolution the antenna radiates RF (radio frequency) power in the form of a highly directional beam. “Super” beams having horizontal beamwidth on the order of one 1 degree or less provide highly precise bearing information. The sharper the beam, the more accurately the bearing of a target can be determined.

## How the Radar displays targets

Radar targets are displayed on what is called a Plan Position Indicator, or PPI. This display is essentially a polar diagram, with the transmitting ships’ position at the center. Images of target echoes are received and displayed at their relative bearing, and at their distances from the PPI center. Early model Radars displayed targets and possess few features such as heading marks and range rings. To view the display, a viewing hood was required to block out extraneous light.

Almost all late model Radars use Liquid Crystal Display (LCD) or daylight bright Cathode Ray Tube (CRT) displays. These types of displays provide steady, bright, non-fading Radar echoes in monochrome or color depending on model. The picture is visible even in full daylight. Digital information is displayed on-screen to keep you informed of your navigational situation at all times.

## Radar range

Atmospheric conditions and target shape, material and aspect slightly affect Radar range. However, Radar range is generally calculated as follows:

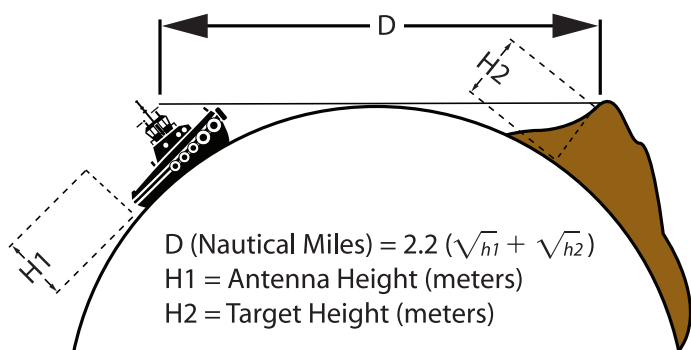

Figure 1 - Determining Radar range

D is the distance from the scanner to the target horizon. Under normal atmospheric conditions, this distance is 6% greater than the optical horizon. This is because radio waves bend or refract slightly by atmospheric change.

The higher the scanner or target is above the surface, the longer the detection range. For example, if the scanner is 9 meters above the sea surface and the height of the target is 16 meters, you should be able to see the target's echo on the display when the target is 15 miles from the Radar.

## Unusual propagation conditions

Air ducts created by atmospheric conditions can affect radio pulse propagation and thus Radar range. When the radio pulse is bent downward, radio pulses can travel great distances thereby increasing the ranges at which targets can be detected. This is called super-refraction. The opposite condition, in which Radar waves bend upward and decrease the range at which targets can be detected, is called sub-refraction.

## Radar System Configuration

### Basic system

The basic Radar system consists of two units: the scanner unit and the display unit. The transceiver (transmitter/receiver unit, or t/r) is generally housed in the gearbox of the scanner unit. In some designs the t/r is separate from the scanner unit and contained in its own housing; such a unit is referred to as 't/r down.' Also, the control unit may be separate from the display unit so as to allow for custom selection of display in what is referred to as a 'black box' system.

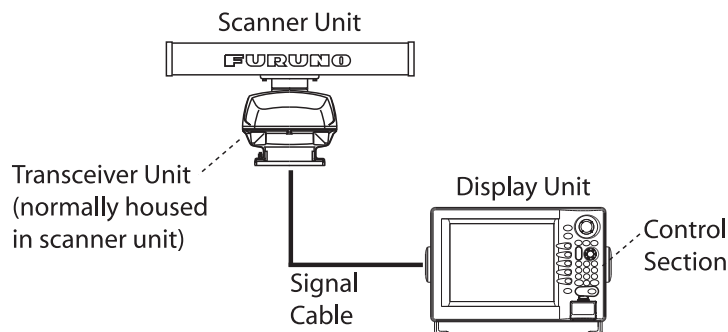

Figure 2 - Basic Radar system

### Scanner unit components

Most scanner units employ the circuits and devices shown in Figure 3:

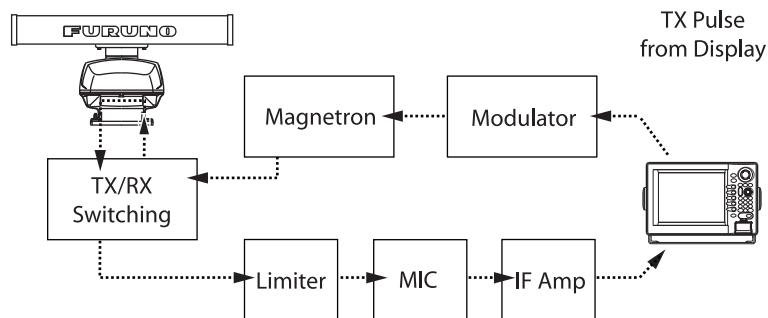

Figure 3 - Circuits and devices of a scanner unit

### Magnetron

The magnetron generates the radio pulses. Magnetrons, as well as the Radar itself, are classified by their transmitting frequency band. There are two main frequency bands in commercial Radar: X-Band (9,000 MHz band; wavelength 3cm) and S-Band (3,000 MHz band; wavelength 10 cm). Magnetron output power ranges from 1kW for small Radars to 60kW for large Radars. Table 1 compares the S-Band and X-Band frequencies.

Table 1 - Comparison of X-Band and S-Band

Frequency Band	Characteristics
X-Band	<ul style="list-style-type: none"> <li>Short wavelength for better directivity</li> <li>Attenuation in precipitation is greater than on S-Band</li> <li>Small, light-weight antennas</li> </ul>
S-Band	<ul style="list-style-type: none"> <li>Longer wavelength for long range detection</li> <li>Penetrates precipitation for excellent performance in inclement weather</li> <li>Large antenna</li> </ul>

### Modulator

The device responsible for monitoring the magnetron for proper operation is the modulator. It ensures that the magnetron transmits at exactly the same frequency throughout the duration of the pulse, and that the time between pulses is the proper length.

### TX/RX Switching

A TX/RX switching device enables the Radar to transmit the radio pulse and receive its reflected echo through one scanner. The switching device used by the Radar is called a circulator. It consists of a permanent magnet and a ferrite core. When transmitting, it directs radio pulses to the scanner and disconnects the receiver circuits. When receiving, it funnels weak reflected echoes away from the magnetron to prevent both flow to the magnetron and loss of receive signal.

### Scanner

The scanner transmits the radio pulses and receives their reflected echoes. Most scanners rotate at a constant speed of 24 rpm. Many modern Furuno Radar scanners rotate at variable speeds dependent upon the range in use in order to optimize Radar detection. The type of scanner used by most vessels is the slotted array, an antenna with a series of slits spaced at suitable intervals and angles from which radio pulses are transmitted. The reflected echoes also pass through these slits.

Figure 4 - A typical slotted array scanner



The length of the array affects horizontal beamwidth, and thus the Radar's ability to determine target bearing. The longer the array, the more accurately the Radar can determine bearing. For example, an array of 50 cm length gives a horizontal beamwidth of 5 degrees, while one of 300 cm length gives a horizontal beamwidth of 0.75 degrees.

Scanner directivity is a measure of the two beamwidths. One is in the horizontal plane, known as horizontal beamwidth, and the other is in the vertical plane, known as vertical beamwidth. The narrower the horizontal beamwidth the sharper the beam. The vertical beamwidth should be wide; it is typically 20 to 25 degrees. The main reason for a wide vertical beamwidth is to ensure the ability to display a target while own ship is pitching and rolling.

### Limiter

The limiter protects the receiver circuits from damage in the event own ship's Radar receives radio pulses from another ship's Radar. When this occurs, the limiter attenuates them to protect the next stage MIC (Microwave Integrated Circuit).

### MIC

MIC is an acronym meaning Microwave Integrated Circuit. The MIC consists of a local oscillator and mixer circuits. Incorporating those devices on an IC improves quality, reliability, sensitivity and noise figure (nf).

### IF Amplifier

The IF amplifier amplifies the Intermediate Frequency signal output by the MIC.

### Display unit components

Most display units employ the devices shown in Figure 5:

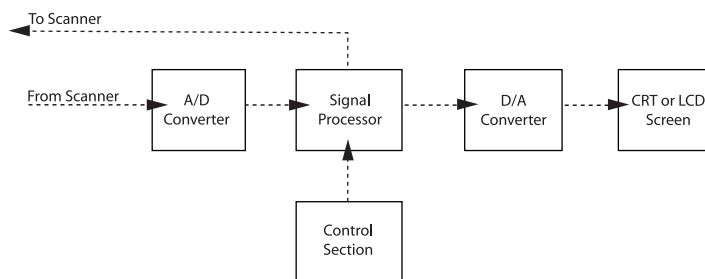

Figure 5 - Devices of a display unit

## A/D Converter

The received IF signal is an analog signal. This signal is converted to a digital signal in order to undergo various processing in the display unit. The A/D (Analog to Digital) converter converts analog signals to digital signals.

## Signal Processing

This section is the heart of the Radar and contains computers, memories, and other IC's. Extensive use of digital techniques permits high speed processing.

## Control Unit

The control unit contains various keys and controls for adjustment of the Radar picture. Whenever a control setting is changed the associated reaction appears almost immediately on the display. In some Radar designs, the control unit is separate from the display unit.

## Basic Radar Terms

**Radar Resolution:** Different than display resolution, which is a measure of the pixels in an LCD display, Radar resolution describes the Radar's ability to distinctly display two Radar targets which are close to each other. Radar has two types of resolution: range, and bearing.

Bearing resolution is a measure of the capability of the Radar to display as separate targets the echoes received from two targets that are at the same range and close together. The principal factor affecting bearing resolution is horizontal beamwidth. The narrower the horizontal beamwidth the better the bearing resolution.

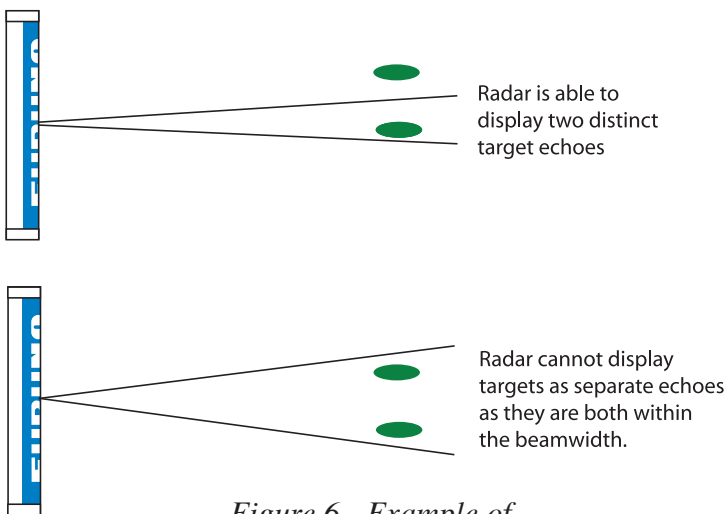

Figure 6 - Example of bearing resolution

Range resolution is a measure of the capability of the Radar to display as separate pips the echoes received from two targets that are on the same bearing and are close together. The main factor that affects range resolution is pulselength. A short pulselength gives better range resolution than a long pulselength.

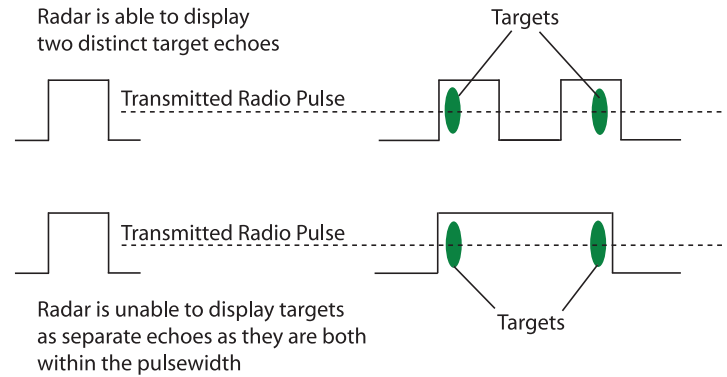

Figure 7 - Example of range resolution

Generally, use a short pulselength on short ranges for better range resolution, and a long pulselength on long ranges for longer range detection.

**Beamwidth:** Beamwidth is the angular width, horizontal or vertical, of the path taken by the Radar pulse. Horizontal beamwidth ranges from 0.75 to 5 degrees, and vertical beamwidth from 20 to 25 degrees.

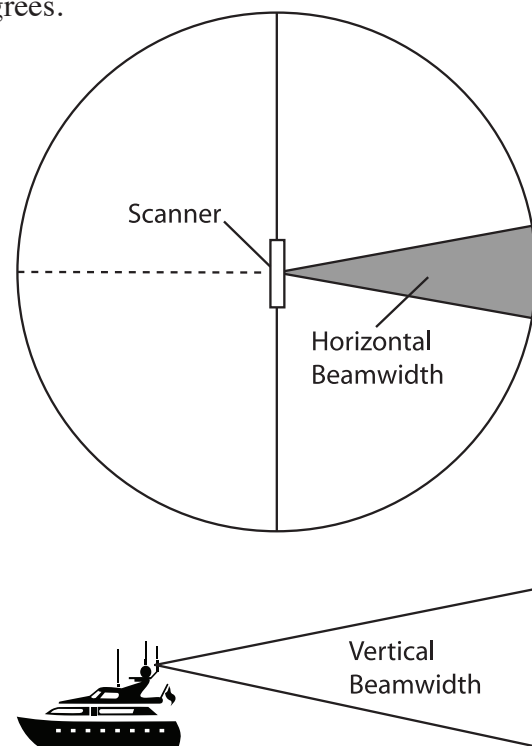

Figure 8 - Example of scanner beamwidth

**Pulse Repetition Rate:** Pulse repetition rate is the number of radio pulses transmitted in one second. It is automatically determined by pulselength and detecting range. For short ranges, pulselength is short and the pulse repetition rate is high. For long ranges, pulselength is long and the pulse repetition rate is low.

**Minimum detectable range:** This is the minimum range at which a target is detectable by the Radar. It is determined by scanner height, vertical beamwidth, blind sector within the scanner beam, and pulselength.

**Maximum detectable range and output power:** Doubling the output power of a typical Radar raises the maximum detectable range by only 19 percent. In the reverse case, halving the output power lowers the maximum detectable range by 16 percent. While you can increase the maximum detectable range by using a high output power Radar, a better (and more economical) way to do it would be to mount the scanner as high as possible above the waterline and/or utilize a longer antenna to increase horizontal beamwidth.

## 2. RADAR CONTROLS

This section briefly describes the function, objective and usage of Radar controls. Note that some controls described here may not be provided on your Radar. For detailed control description, refer to your Operator's Manual.

### Precautions:

**A rotating scanner is dangerous.** Before turning the Radar on, be sure no one is near the scanner unit.

The scanner unit emits high frequency radio pulses, which can be harmful, particularly to your eyes. Never look directly into the scanner unit when the Radar is in operation.

**Key response:** The Radar normally releases a beep when you correctly enter a command. If no beep is released, try again. Incorrect command generates several beeps. This function can usually be disabled, but caution must be used as this audible feedback is important to verify correct entry of commands.

### Control Description:

**Power:** Powers the entire Radar system. After turning on the power, a timer displays the time remaining for transmission preparation. "ST-BY" appears when the Radar is ready to transmit. The method of turning off the power varies by model; consult your Operator's Manual for details on powering off your Radar.

**Economy:** The economy mode turns off power to the display in stand-by to lessen power consumption.

**Trackball/Cursor Pad:** The trackball or cursor pad shifts the cursor, which sets the guard zone, displays range and bearing to a target, etc. Some models may have individual arrow keys in place of a trackball or cursor pad.

**Scanner:** This switch starts and stops scanner rotation. Turning the switch off when transmitting sets the Radar in stand-by. A rotating scanner can be dangerous - before turning the switch on, be sure no one is standing near the scanner unit.

**ST BY/TX:** Press this key to transmit radio pulses. To stop transmitting, press the key again.

**Gain:** This control adjusts receiver sensitivity. Adjust the gain to increase sensitivity and display echoes. For long range, adjust the control so background noise is just visible on the display. For short range, some Radar operators set this control relatively high and adjust sensitivity using the A/C SEA control.

**A/C Rain (FTC):** The Rain control, also called FTC (Fast Time Constant), suppresses the reflected echoes from rain, hail and snow to clear the display. On the X band Radar, because of its short pulselength, the echoes from legitimate contacts can become lost in the echoes from precipitation, called rain clutter. When rain clutter masks the display, adjust this control to break up the clutter and distinguish echoes. Adjust the control so that the clutter just disappears; too much A/C Rain action may shrink or erase the echoes from legitimate targets.



**A/C Sea (STC):** Sea control, also called STC (Sensitivity Time Constant), suppresses reflections from waves near own ship. In rough seas the reflected echoes from wave crests are very strong, producing a mass of echoes which cover the central part of the display. This is called sea clutter. Any echoes within the clutter will be partially or totally obscured. Adjust this control to reduce the clutter and distinguish echoes. The proper setting should be such that the clutter is suppressed and echoes become distinguishable. If the control is set too high, both sea clutter and echoes will disappear from the display. When there is no sea clutter visible on the display, turn the control fully counterclockwise.

**Brill:** This control adjusts the display brilliance.

**Range:** Press the [+] and [-] keys to raise and lower the range respectively. When you change ranges, the number of range rings and range ring interval as well as pulselength are automatically changed. For confirmation, the range and range ring interval appear on the display.

**Rings:** Press this key to show or hide the range rings. Range rings provide an estimate of the range to a target. The number of range rings and range ring interval automatically change with the range. Ring interval (distance between rings) appears on the display.

**VRM:** The VRM (Variable Range Marker) measures the range to targets. To measure range, press the key to display the VRM. It appears as a dashed circle. Adjust the VRM so that it touches the inner edge of the target. The range to the target appears in a data box on the display. Some Radars may display two VRM's; the length of the dash of the #2 VRM is longer than that of the #1 VRM.

**EBL:** The EBL (Electronic Bearing Line) measures bearing to targets in degrees. To measure bearing, press the key to display the EBL. It appears as a dashed line. Adjust the EBL so that it bisects the target. The bearing to target appears in a data box on the display. Some Radars can display two EBL's; the length of the dash of the #2 EBL is longer than that of the #1 EBL.

**Offset EBL:** This EBL can be shifted to any location on the display. This allows you to predict other ships' course (to avoid collision) and measure the range and bearing between two targets.

**Plot:** This function plots the movement of all ships relative to own position. Press the key to start plotting. The positions of all targets at the end of the preset time are marked on the display.

**Echo Trails:** This feature continuously shows the movements of other ships in afterglow. It is useful for assessing target movement and collision possibility.

**Display Mode:** The display mode determines target position and movement on the display. There are two types of display mode: Relative and True.

- **Relative Bearing Display:** This mode is also known as Head-up, since own ship's heading is always at the top of the display. The position of own ship is fixed and echoes of all other objects therefore move relative to own ship. This is the usual form in small Radar sets.
- **True Bearing Display:** This mode is sometimes called North-up since the display is oriented North. This mode is suitable for long-range observation since it is somewhat like looking at a nautical chart.

**Off Center:** This key shifts the display center to location desired. The off-center display allows the operator to view the situation around own ship without changing the range. Set the cursor where you want the center position to be, and then press the key. To cancel the off-center display, press the key again.

**X2 Zoom:** The X2 ZOOM feature allows you to take a closer look at a target of interest. Set the cursor near the object you want to zoom and press the key. To cancel zoom, press the key again.

**Index Lines:** Index lines are useful for maintaining a constant distance between own ship and the coastline or a partner ship. Press the key to toggle index lines on and off.

**Interference Rejection:** This control reduces or eliminates interference received from another ship's Radar. Turn it off when no Radar interference exists.

**Guard Alarm:** The guard alarm creates a zone about own ship, either complete 360 degree zone or a specific area forward of own ship. If targets enter or exit the zone an audible alarm sounds to alert the operator.

**Echo Averaging:** The Radar's internal circuitry processes echo data to obtain a desired effect. The result depends on the Radar model. For example, some Radars may suppress brilliance of unstable echoes (sea clutter, etc.), or emphasize an unstable small echo.

**Hue, Color, Background Color:** These settings change display color and background color respectively to improve display visibility. Note that marks and characters also change color when the keys are pressed.

**HM Off:** The heading mark may sometimes hide a small echo. To show that echo, press and hold down the HM OFF key to temporarily erase the heading mark. Release the key to display the heading mark.

**Echo Stretch:** This function 'stretches' small echoes to make them easier to see. It stretches not only small echoes but also returns from sea and rain clutter and Radar interference. For this reason, make sure clutter and interference are sufficiently suppressed before using echo stretch.

**NAV:** This key shows/hides navigation data, including position, range and bearing to waypoint, ship's speed and more. This feature usually requires a navigation aid which can output data in NMEA0183 or NMEA2000 format. If a gyrocompass is connected to the Radar, a dashed line connects navaid-selected waypoint with own ship's position.

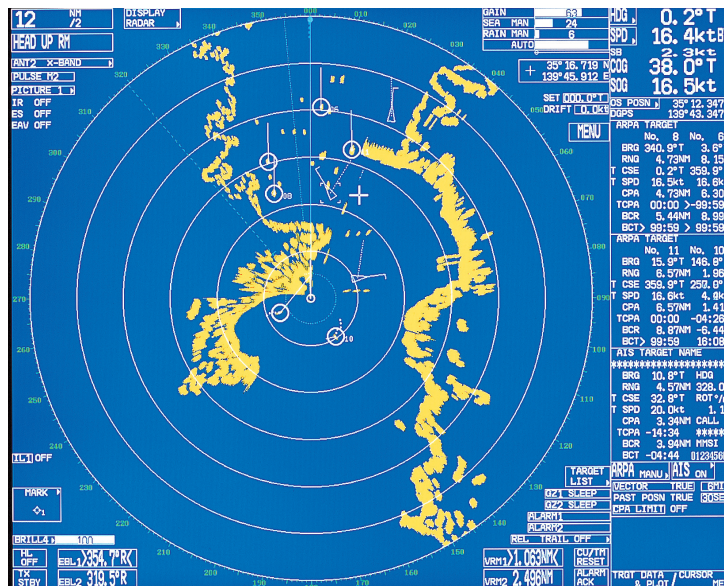

Figure 9 shows a sample Radar display. Own ship's position is at the display center. The Radar range is 12 nautical miles and the range ring interval is 2 nautical miles. The circled objects are ARPA targets and the triangle objects are AIS targets. The large, continuous echoes are from land masses. Note that the actual shape of a target cannot be displayed on the Radar - only the portions struck by the radio pulse appear on the display.

# Targeting Birds With Your Furuno Radar

It's a well known fact that if you want to catch fish you need to know how to find them, and in order to find the fish, you need to locate the birds - the undisputed masters of fish finding technology. What is less clear is exactly how to go about targeting birds with Radar, a tool normally reserved for collision avoidance. This section will remove some of the mystery surrounding the subject.

The first thing to think of when considering bird-tracking Radar is antenna beamwidth. Remember that the narrower the beamwidth, the greater target discrimination you will have. For this reason, dome antennas are not as adept at tracking birds as a comparable open array antenna. As the length of the antenna radiator increases, beamwidth becomes narrower, so a larger antenna will invariably offer better target discrimination.

Experience and practice will make you a bird-finding machine, but to get there you need to start with the basics. For the novice, it is best to practice these techniques on a clear day with calm seas. It is easiest to first visually locate a flock of birds that you want to target.

To target the birds, set the Radar to a mid- or long-range. Next, increase the Gain control until you see noise on the display. This will appear as a blanket of small specks. You will need to leave the Gain turned all the way up, thus setting the receiver

should be able to see them clearly. This is what you will be looking for when you don't have a visual cue as to where the birds are feeding.

If your Radar is capable of operating in True Motion, do so. You will be stabilizing the display, and you will be able to tell if the flock is travelling in a straight line looking for bait pods or if they have found their target school and are feeding.

When operating in Head Up or True Motion, be sure to turn on your target trail function and set it for long trails to help track travelling flocks.

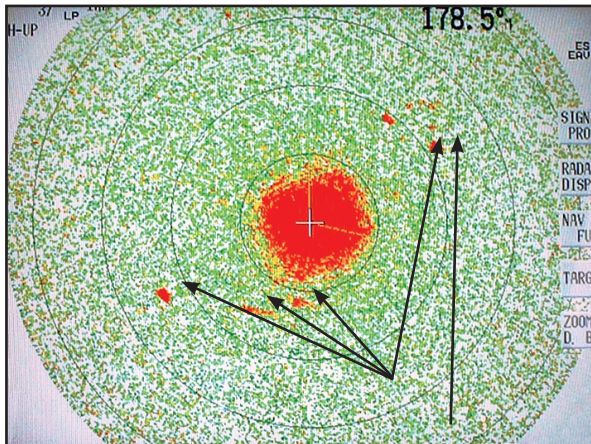

*These birds were targeted using the Furuno 1954C NavNet Radar. True Color is highly desirable when targeting birds, as demonstrated above; these flocks were easily picked out in red against the blanket of clutter.*

for maximum sensitivity in order to detect birds. Resist the temptation to turn up the AC/Sea or AC/Rain to drop out the noise. Flocks of birds may look like dense, recurring noise rather than a solid target, but you

Practice these techniques and soon you will be scouting your fishing spots just like the pros.

## Radar Factoids - UHD Digital Radar

Furuno's NavNet 3D integrates Ultra High Definition (UHD) Digital Radar that facilitates fully automatic, high-precision Gain, Sea/Rain Clutter and Tuning control that allow the auto mode to adapt to a variety of sea-states for hands-free operation and ultimate performance.

One amazing features of Furuno UHD Digital Radar is 'Real Time' dual range Radar display. NavNet 3D simultaneous scanning technology allows dual progressive scan to display and update two Radar pictures, both long and short range, at the same time as opposed to the alternating update methods of typical conventional dual range Radars. This can be used to have one screen with the gain set to locate birds and buoys, while you use the other Radar screen to navigate.



*UHD™ offers crystal clear, noise-free target presentation with automatic real-time digital signal processing. Antenna rotation speed (24/36/48 rpm) is automatically shifted to the appropriate pulse length.*

## Radar Picture and Marks

The Radar display shows you not only echoes but also marks and information. This section describes the Radar picture and marks you will see on the display.

### Measuring Range

The range from own ship to target can be measured in three ways: by range rings, by cursor, and by VRM.

#### By Range Rings:

The RINGS key shows/hides the range rings and adjusts their brilliance. To measure range by the range rings, count the number of rings between the center of the display and the echo. Check the range ring interval at the top of the display and judge the distance of the echo from the inner edge of the nearest ring.

#### By Cursor:

The cursor provides a more accurate measurement of range to targets. Set the cursor intersection on the inner edge of the target. The range from own ship to target appears on the display.

#### By VRM:

The VRM, like the cursor, provides a more accurate measurement of the range to targets. Display a VRM and adjust it so that it rests on the inner edge of the target. The range to target appears on the VRM readout.

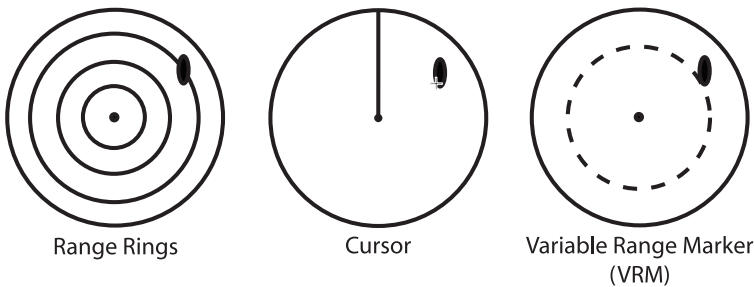

Figure 10 - How to measure range

### Measuring Bearing

The relative bearing from own ship to targets can be measured by the cursor and by the EBL. With gyrocompass connection, you can display true bearing.

#### By Cursor:

Set the cursor intersection on the center of the echo. The bearing from own ship to target appears on the display.

#### By EBL:

Display an EBL and adjust it so that it bisects the target. The bearing to the target appears on the EBL readout. Bearing relative to heading is relative bearing, while bearing relative to North is true bearing.

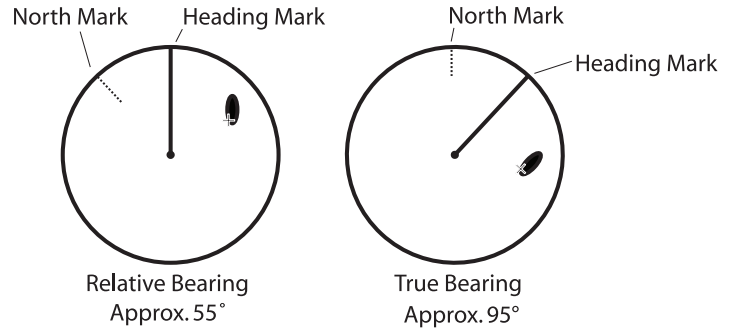

Figure 11: Comparison of true and relative bearing

#### No Gyrocompass Connection:

You can determine true bearing by adding relative bearing to your compass reading. If the sum is over 360 degrees, subtract 360 from the number.

#### Gyrocompass connection:

Select the true bearing display, north-up mode. Measure the bearing by the EBL and check the EBL readout.



AIS provides real-time information on AIS-ready chart plotter, navigation presented graphically, allowing you to see vessels in the area. Since AIS targets can be out of line of sight, the system greatly enhances safety on waterways, limited visibility or heavy sea conditions. Get more information about AIS equipped vessels.

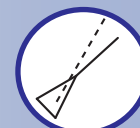

ROT Higher Than Preset ROT



Dangerous Target



Activated

## How to Suppress Sea Clutter

The effect of echoes with waves changes with wave size, sea conditions, weather and antenna height above the sea surface. Sea clutter can be suppressed by not only the **A/C SEA** controls but also by a combination of **A/C RAIN** and **GAIN** controls.

### General Procedure:

Turn the **A/C SEA** control fully counterclockwise (down). Turn the **GAIN** control fully clockwise (up). Slowly turn the **GAIN** control counterclockwise (down) to reduce sea clutter and distinguish targets. Note that echoes that are weaker than the sea clutter will not appear.

If this action does not remove sea clutter near own ship, gradually turn the **A/C SEA** control clockwise (up) to reduce sea clutter.

**NOTE:** *The **A/C RAIN** control is also effective in suppressing sea clutter. It is most effective when the echo of the target is larger than that of the sea clutter. Its main advantage over the **A/C SEA** control is that, when used to suppress sea clutter, it does not shrink small echoes.*

## How to Suppress Rain Clutter

Echoes from precipitation cover a much wider area on the display than echoes from waves. However, since they are not as strong as those from waves, they can be suppressed by adjusting the **A/C RAIN** and **GAIN** controls.

### Example 1: Drizzle over a wide area

If using the **A/C RAIN** control shrinks or erases echoes, turn the **GAIN** control clockwise (up) until rain clutter just appears on the display.

### Example 2: Density of rain different from area to area

In this instance you usually reduce the clutter in the area of light rain by adjusting the **A/C RAIN** control. Be careful not to remove the clutter completely; weak echoes may be missed. If strong clutter appears in the area of heavy rain, turn the **GAIN** control counterclockwise (down) a little.

# AIS

## Automatic Identification System

Information about AIS-equipped vessels on your own software or Radar. This information is used to monitor and avoid AIS equipped vessels. You will receive even if they are not within your range. This provides situational awareness in congested conditions, and gives the navigator much more information. Some common AIS symbols are:



# ARPA

## Automatic Radar Plotting Aid

An ARPA target is measured by range and bearing from own ship and located on the Radar PPI. When ARPA and AIS are combined and their symbols are within an operator-set criteria, the ARPA symbol is merged with the AIS symbol. Some common ARPA symbols are:

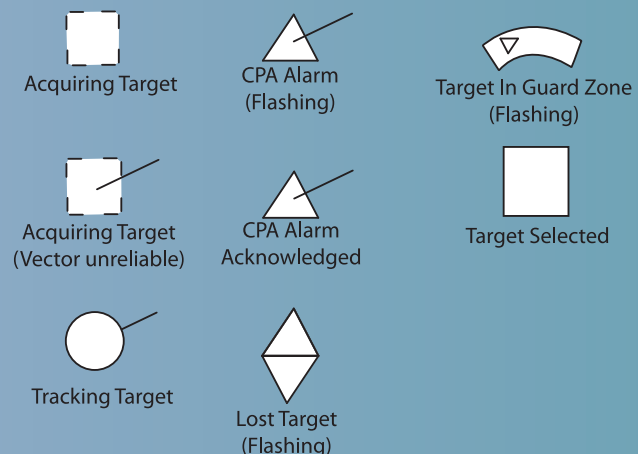

### 3. INTERPRETING THE DISPLAY

This section provides the information necessary for interpreting the display.

#### Radar Picture and Target Properties

The strength of the reflected echo depends not only on the height and size of the target, but also its shape, material composition and angle at which the radio pulse strikes. The size of the target actually has little to do with the reflected echo. If the radio pulse strikes it at a right angle, even a small target will return a strong echo provided that the material is a good reflector of RF energy.

A return echo will be weak if the angle at which the radio wave strikes a target is small. For example, flat surfaces such as sandy beaches, sandbars and mudbanks have almost no area that can reflect energy back to the Radar. Conical surfaces, such as lighthouses, generate weak return echoes because their shape diffuses most of the radiated energy. Because of their poor reflecting properties, flat or conical surfaces do not return an echo suitable for range determination.

Radar sees only the near side of targets. For example, it cannot show you what is behind a sea wall or an island. The echo of a mountain peak may appear on the Radar display as a peninsula or small island. The Radar image is not always as it seems - you should always exercise caution when interpreting the display.

#### Target material and reflected echo

Generally, steel objects return a very strong echo while reefs and water return weak echoes. The weakest echoes come from wood and fiberglass objects. In summary, non-metallic objects or those that are flat or conical in shape do not make good Radar targets, and the Radar may display only weak, intermittent echoes - or it may not display them at all.

#### Precipitation

Rain, snow and hail may return echoes which appear on the display as a blurred or cluttered area. You can suppress them by adjusting the A/C RAIN control, or lowering the sensitivity.

#### Influence of Waves and Precipitation

On short range, a mass of echoes covers the central part of the display. This is caused by echoes from waves, called sea clutter. The higher the waves the more extensive the sea clutter on the display. In most cases it is more pronounced to the windward side of the vessel. To suppress sea clutter, use the A/C SEA control. Always leave a little sea clutter on the display to be sure weak target echoes are not erased.

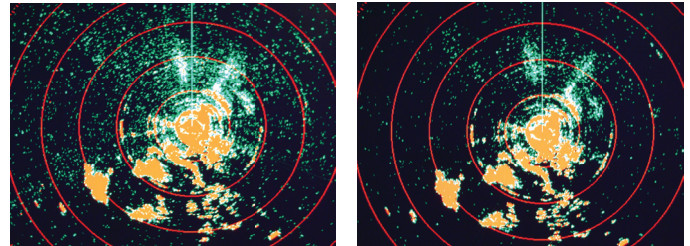

#### ARPA and AIS

ARPA is an acronym that stands for Automatic Radar Plotting Aid. The ARPA functions as a collision avoidance tool, tracking individual Radar targets and plotting their course and speed in order to determine the closest point of approach (CPA) and time to closest point of approach (TCPA) to own vessel. Data such as course, speed, range, bearing, CPA and TCPA can be called up in a data box on the screen simply by selecting the target of interest.

AIS is an acronym that stands for Automatic Identification System. The AIS system is used to exchange vessel and navigation data including vessel name and call sign, length and beam, position with accuracy indication and integrity status, course, speed, heading and ROT and other specific information, all in real time. Data is shared with other nearby ships as well as coastal VTS (Vessel Traffic Service) stations. Unlike ARPA, which is dependent upon Radar returns to track targets, AIS targets are acquired and tracked via VHF (radio) signal. This means that AIS-equipped targets that are partially or totally obscured from the sweep of the Radar can still be acquired and tracked if within VHF coverage.

## Other Aids To Navigation

The Radar display sometimes shows a series of dots or dashed radial lines. They are navigational marks transmitted by Radar beacons. A Radar beacon transmits a coded signal when it receives a radio pulse from a Radar, and some Radar beacons transmit continuously. Its main purpose is to help the navigator find his own position in terms of range and bearing from the beacon. There are two main classes of Radar beacons: RACON and RAMARK. Another type of Radar beacon is called a Search And Rescue Transponder, or SART. When activated by a crew member on a ship in distress it transmits a distinctive signal when its transmitter is triggered by a radio pulse.

### RACON

The RACON (RADar beaCON) automatically transmits a signal when it receives a radio pulse. The signal transmitted by the RACON appears intermittently on the display as a Morse character, a dashed or dotted line radiating out from the beacon. In the U.S., RACONs are used to mark lighthouses and buoys, inconspicuous coastlines, navigable spans under bridges, offshore structures such as oil platforms, or environmentally sensitive areas such as coral reefs.

### RAMARK (Radar Marker)

The RAMARK is a Radar beacon which transmits either continuously or at intervals. When a Radar scanner faces a RAMARK it receives the RAMARK signal. The RAMARK signal appears on the display as a Morse character, a dashed or dotted radial line. RAMARKs are not commonly used in the U.S.

### SART (Search And Rescue Transponder)

When a Radar transponder is activated by a ship in distress, its transmitter emits a signal when activated by a radio pulse. The appearance of the signal on the display depends on the distance between the Radar and the transponder. The closest transponder signal to own ship position is the approximate position of the ship in distress.

In the GMDSS (Global Maritime Distress and Safety System), certain classes of vessel must carry a SART. You should continuously monitor the display for Radar transponder signals. Be prepared to offer assistance to a ship in distress if required.

## False Echoes

Occasionally false echoes appear on the screen at positions where there is no target. In some cases the effects can be reduced or eliminated. The operator should become familiar with the appearance of these false echoes so as not to confuse them with echoes from legitimate contacts.

### Indirect echoes

Indirect echoes may be returned from either a passing ship or from a reflecting surface on your own ship, such as a stack. Figure 12 illustrates the effects of an indirect echo. Indirect echoes may be recognized as follows:

- They usually occur in shadow sectors
- They appear on the bearing of the obstruction but at the range of the legitimate contact
- When plotted, their movements are usually abnormal
- Their shapes may indicate that they are not direct echoes

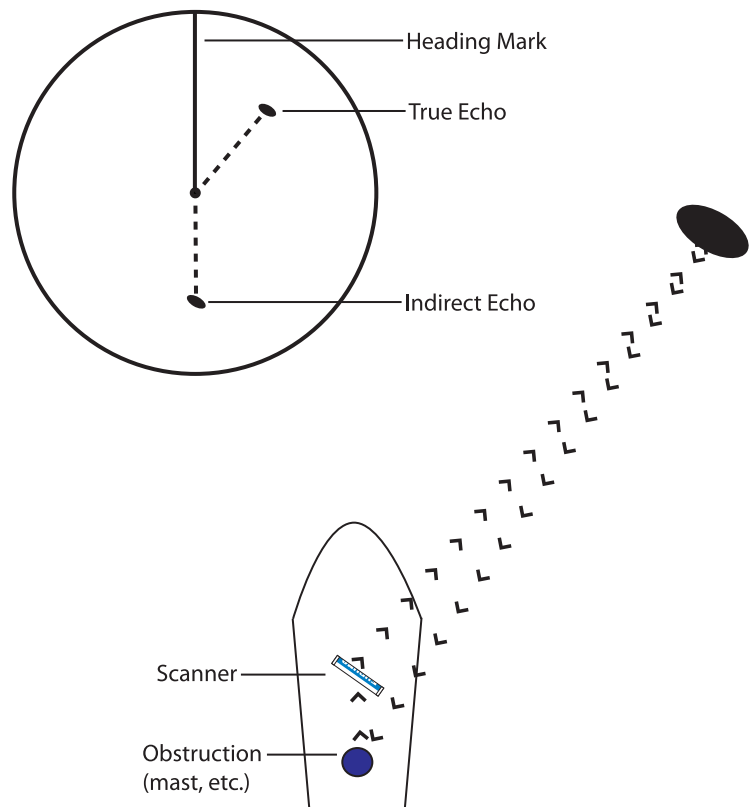

Figure 12 - Example of Indirect Echo

## Multiple Echoes

Multiple echoes can occur when a strong, short-range echo is received from a target. A second, third or more target may be observed on the display at double, triple or other of the actual range of the target. Multiple reflection echoes may be reduced or often eliminated by decreasing the sensitivity.

## Blind and Shadow Sectors

Funnels, stacks, masts or derricks in the path of the antenna may hide Radar targets which are behind them. If the angle subtended at the scanner is more than a few degrees a blind sector may be produced. Within the blind sector small targets at close range may not be detected while larger targets at much greater range may be detected.

## Side Lobe Echoes

Every time the scanner rotates, some radiation escapes from each side of the beam. This energy is referred to as side lobe energy. If a target exists where it can be detected by the side lobes as well as the main lobe, the side lobe echoes may be represented on both sides of the true echo at the same range. Side-lobes usually only show at short ranges and from strong targets. They can be reduced through careful reduction of sensitivity or proper adjustment of the A/C SEA control.

## Radar Interference

Radar Interference occurs when in the vicinity of another Radar operating on the same frequency band, normally 9GHz; 3GHz for large Radars. It is usually seen on the display as large numbers of bright dots either scattered at random or in the form of dotted lines extending from the center to the edge of the display. The interference effects are easily distinguishable from normal echoes because they do not appear at the same places on successive rotations of the scanner. You can reduce the interference effects by turning on the interference rejection.

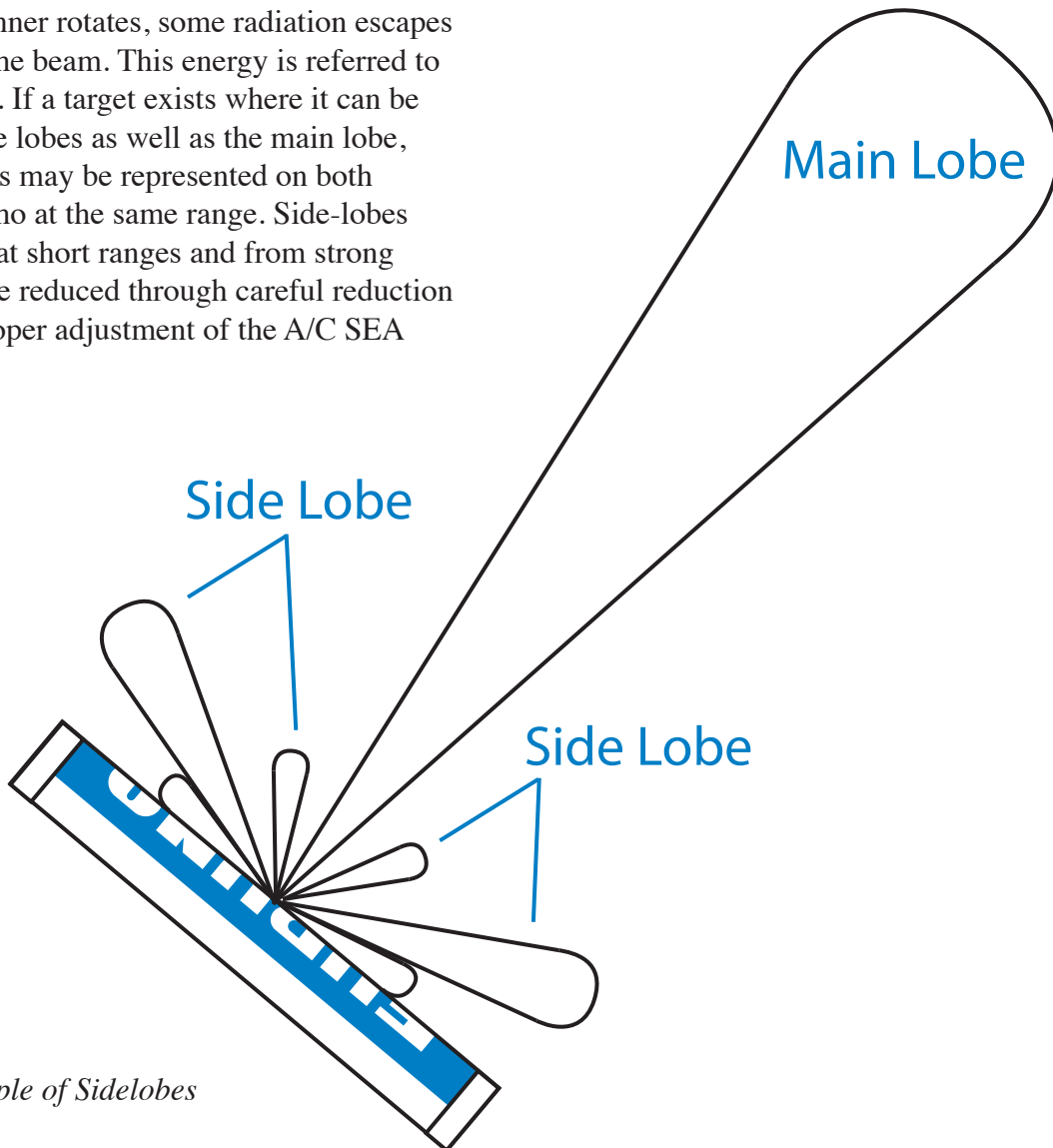

Figure 13 - Example of Sidelobes



# Radars FAQ's

We've gathered a list of some of the most frequently asked questions about Radars and provided the answers in this section. If you have a question that is not answered in this book, you can visit us on the web at [www.FurunoUSA.com](http://www.FurunoUSA.com) and click on the Support button. You can browse through answers to questions, or search for your answer by model, topic or keyword. If you can't find the answer you're looking for, you can send an E-mail directly from our web site to our technical support staff. A knowledgeable technician will respond with your answer, generally within 48 hours.

## **Q: How do I adjust my new Furuno Radar for the best presentation?**

A: Normally the auto features will work well for most situations. If you want to adjust the Radar manually try the following:

- 1) Transmit the Radar in maximum range
- 2) Set STC (sea clutter) to minimum
- 3) Set FTC (rain clutter) to minimum
- 4) Set the gain control to maximum (the screen should show mostly Radar noise)
- 5) Now adjust the gain control to show a very small amount of noise (only a few noise spots on the screen)
- 6) Without disturbing the gain control select the appropriate working range
- 7) Adjust STC (sea clutter) as desired
- 8) Adjust FTC (rain clutter) if needed

Note: The timing and heading must still be set according to the procedure listed in the installation manual.

## **Q: Should I manually tune my Furuno Radar or use the automatic tuning feature?**

A: Unless a problem is suspected with the automatic tuning circuit, automatic tuning is superior to manual tuning. The automatic tuning circuits adjust the receiver sensitivity to each transmitted pulse. It would be impossible to duplicate this procedure using manual tuning. Most Furuno Radars have an automatic tune compensation adjustment that must be done as part of the initial installation alignments. See installation manual for more information on initial set-up.

## **Q: My Radar is showing targets in the wrong place (i.e. the buoy in front of the boat is showing on the Radar as a target behind the boat). My compass heading input is correct and the Radar is in head-up mode. How do I correct this?**

A: All Radars require a heading alignment upon installation of the Radar antenna. Refer to your installation manual for the proper procedure in completing this adjustment. Once you complete the heading alignment the targets should show in the correct places.

## **Q: My Radar turns on but will not go into transmit. It has a message on the screen that says HD/BP, what does that mean?**

A: The error message "HD/BP" indicates that the display is not getting heading or bearing pulse signals. The first step is to see if the antenna is turning. If you have an open array this is easy to check, but if you have a radome antenna you will need to remove the cover to check for rotation. You will need to contact an Authorized Furuno representative. This information will help them start the troubleshooting process.

## **Q: How does UHD Radar work?**

A: Furuno's Ultra High Definition Radars use a new digital processing technique that effectively doubles the scan lines on the screen, dramatically improving resolution. Additionally, vastly improved Auto Modes employ digital filtering and modeling techniques that allow the Radar to adapt to a variety of sea states.

## Radar FAQ's continued ...

### **Q: Can I cut my Radar cable to length or should I coil it and store it?**

A: It is not recommended to cut your Radar cable. Find a place to hide and coil the excess. If there is no other way to hide the cable, it can be reduced in length but this should be done by an authorized Furuno USA dealer. If not performed correctly, cutting the cable could lead to corrosion and may result in voiding the warranty. Adjusting the cable length will also affect the timing of the Radar. Please confirm that the timing is still correct if any changes are made to the cable length.

### **Q: What are the “streaks” or “spiral lines” that sometimes show up on my Radar display?**

A: If they appear intermittently and then go away, it is most likely Radar interference from other vessels or perhaps even a second Radar aboard your own boat. Furuno Radars offer several levels of interference rejection, or “IR”. IR is usually selectable from a menu setting. Start by applying the first level of IR and see if the interference stops. Even if higher levels of IR are necessary, you will note very little degradation of your Radar picture. CAUTION: Interference Rejection may suppress certain very weak targets and/or Radar signals from RACON buoys.

### **Q: Will I be able to detect weather with my Furuno Radar?**

A: Yes, most marine Radars will detect weather fronts. With Furuno true color Radars you will be able to see individual weather cells at a great distance.

### **Q: I am purchasing a Furuno Radar system and was wondering if I would be better off with an open array unit or a radome type of antenna unit?**

A: Generally speaking, an open array Radar antenna will have better performance than a radome antenna of comparable output power. The open array antenna focuses its output beam better than the radome, resulting in better bearing resolution and target discrimination. This focus is best measured by the horizontal beam width of an antenna. The smaller the horizontal beam width the better the target resolution. If you have the space, the open array is the best choice for maximum performance.

### **Q: Is the radiation coming from my Furuno Radar dangerous?**

A: It is the consensus of the scientific community that the level of radiation exposure from Marine Navigation Radars is well below that which is permissible under current regulatory and professional guidance, and poses no real health threat. Marine Radars are actually very low “average power” systems, the hazards from which are normally insignificant. We do not, of course, recommend looking into a Radar that is mounted a few feet in front of you on the same horizontal plane.

### **Q: I have accessed the installation menu for my Furuno Radar but cannot select heading or sweep timing adjustments. When selected with the [ENTER] button the Radar display just beeps twice and nothing happens. Why?**

A: Heading alignment and sweep timing adjustment cannot be selected unless the Radar is in transmit mode. Place Radar in transmit mode before accessing the Installation Menu.

### **Q: My Radar doesn't pick up targets as far as it previously did. What could be the cause?**

A: The most likely cause is the magnetron. Please contact your local Furuno dealer for repair information.

## Radar FAQ's continued ...

**Q: Why does my Furuno Radar transmit for about 30 seconds, beep, and then go into stand-by mode for 5 minutes?**

A: It sounds like you have the Watchman mode turned on. The Watchman mode sets the Radar to stand by and then transmits the Radar at a user selected interval to check for target changes in the Guard Zone. If any changes occur, the Radar will sound an audible alarm, cancel the Watchman mode and continue to transmit. Please refer to your operator's manual for instructions on turning this mode off.

Most Furuno Radars will have a notation of [Watchman] on the display when the function is active and the display will beep when going into or out of this mode.

**Q: Do I need to install a flux gate compass for my Radar/chart overlay and ARPA to work?**

A: Yes. A stabilized heading input is required for both of these features to work.

Radar overlay will work with either an NMEA or Furuno AD10S heading input. NMEA sentences that will work are HDG, HDM, HDT.

ARPA requires the Furuno AD10S heading input at 25 milliseconds. You can use any of Furuno's current flux gate compasses, an AD100 Gyro Converter, or any autopilot or flux gate compass capable of supplying this data format. Furuno's UHD Radars require high-speed NMEA to support ARPA, but do NOT require AD10S

**Q: What is the difference between X-band and S-band Radars?**

A: Simply put, they differ in frequency. The majority of marine Radars operate on X-band. X-band is widely used because of the ability to utilize smaller antennas that fit on most boats and to provide better target resolution. S-band Radars are often used for specialized applications, such as seeing through heavy weather or precipitation and for long-range bird detection. S-band antennas are larger. The smallest Furuno S-band antenna is 9 feet long and can be as long as 12 feet.

**Q: Can I find birds using a Furuno X-Band Radar?**

A: Yes, birds do reflect X-Band Radar signals well enough to be detected. You must use a high power Radar to get a usable level of bird detection. We recommend 12kW of output power or higher to consistently detect birds. Since birds are a small target, the set-up of the Radar must be optimized and the detection range will vary.

**Q: How big does my boat have to be to have a Radar?**

A: There is no size restriction for a boat to have a Radar. As long as you have a stable mounting platform for the antenna and enough dash space to mount a display, Furuno has a Radar for you.

**Q: Is it okay to paint my Radar antenna?**

A: Yes, it is okay to paint your Radar antenna. However, the paint MUST be epoxy-based with NO metallic ingredients. Paint with metallic ingredients will cause poor performance and may cause damage to your Radar.

**Q: My ARPA auto Radar plotter is erratic or drops targets. What could be causing this to happen?**

A: All Furuno ARPA plotters require an AD10 heading input with a 25ms refresh rate. It will not work properly with a GPS NMEA heading input. Please check to make sure you are using the proper type of heading input. The Furuno PG500R or SC30/SC50/SC110 compass will give you the 25ms input that is required.

## Radar FAQ's continued ...

### **Q: What is the difference between a true color Radar and a “color” Radar?**

A: With a true color Radar the return signal strength from the target(s) determines the color represented on the display for the target(s). Strong targets are depicted in warm colors, such as red. Weak targets are represented in cool colors such as yellows and greens.

A good example would be observing a thunder storm with your true color Radar. With the Radar properly set up and adjusted you can see strong cells within the storm depicted in reds. Areas of the storm with light rain are depicted in yellows and greens.

A “color” Radar represents all targets in one color, no matter what the signal strength is.

Note: All Furuno color Radars are true color Radars.

### **Q: Can I mount a masthead light on top of my Radome?**

A: Making any kind of penetration in the upper dome assembly is not recommended and will void your warranty. This almost always leads to water intrusion due to improper sealing, or physical damage to the dome (cracking).

### **Q: I need a replacement upper cover for the radome of my Radar. How do I find the part number?**

A: To find the part number click on the “Search” button on our web site, [www.FurunoUSA.com](http://www.FurunoUSA.com). Enter the model number of your Radar and select the “Find Parts For this Model #(Enter exact Model #)” radio button. Click Search to display a list of parts for your unit and look for the upper radome assembly (ASSY/RADOME UPPER...). If you are not certain of your model number you may try locating your model under the “Products” tab on the top navigation bar.

Once you have located the part number you may contact your local authorized Furuno dealer to purchase this item.

### **Q: The bottom 25 percent of the Radar picture is blank on my 1621 Radar display. The Radar picture above is normal. What could be the problem?**

A: The bottom portion of many of the Furuno Radar displays can be configured to display navigation data from a GPS source, etc. Please follow the steps below to properly configure your Radar display.

- 1) Check in the [MENU] setting for [Nav Data] selected.
- 2) Select [OFF] to display the Radar picture in full screen mode.

Note: If the display is interfaced with a GPS, etc. make sure to power on the device to display the information at the bottom 25 percent of the Radar screen.

### **Q: Why does the lollipop symbol on my Radar bounce around when I am stopped or moving at slow speeds?**

A: The waypoint lollipop gets its heading information from your GPS using Course Over Ground (COG). Since COG is based on changes in your position, it will “bounce” around when you are moving slow or stopped.

# Radars FAQ's continued ...

**Q: What are Radar side lobes and what do they do?**

A: Side lobes are naturally occurring areas of transmitted energy that are part of virtually any transmitter used in marine electronics. Radar, echo sounders (fishfinders) and sonars all generate a “main beam”, which is also known as the “main lobe”. “Side lobes” are transmitted energy that is outside of the “main beam” or “main lobe”.

Reflections from side lobes can sometimes cause false targets and/or “noise” on your display. All Furuno products have gain and clutter controls to help minimize the affects of side lobe returns. Many installation menus and settings exist for fine-tuning Furuno products.

**Q: Why does my Radar have to wait 2 minutes after I turn it on before I get a picture?**

A: The component that transmits Radar energy is called a magnetron and is similar to that which is in your microwave oven, but much more powerful. This is a tube, which will be damaged if the filament isn't heated to a proper temperature. Therefore, Radars have a timing circuit – typically 2 or 3 minutes – which disables the magnetron from transmitting until the filament is sufficiently heated. This protects the magnetron from being damaged.

## Additional Resources

[www.FurunoUSA.com](http://www.FurunoUSA.com):

Visit our web site at [www.FurunoUSA.com](http://www.FurunoUSA.com) for information on the entire line of award-winning Furuno Radars. Browse through our catalog of chart plotters, fish finders, sonar, communication products and PC software to round out your helm.

## Authorized Furuno Dealers:

Your local Furuno dealer is a valuable resource when it comes to answering specific questions about the electronics that are right for you. To find your nearest Furuno dealer, simply go to our web site at [www.FurunoUSA.com](http://www.FurunoUSA.com) and click on Dealer Locator. Enter in your zip code and you will receive a complete list of Furuno dealers in your area.

## Furuno Support Center:

Have a question that needs an answer? Click on support and browse through our extensive library of frequently asked questions. You can also ask our knowledgeable Technical Support staff a question and receive an answer via e-mail.

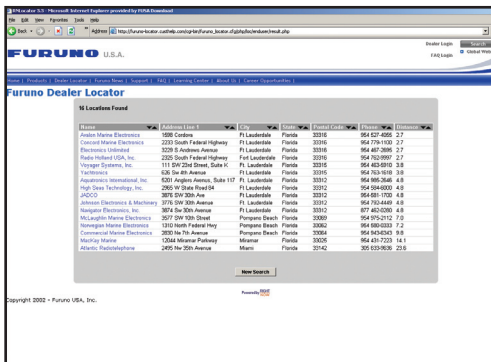
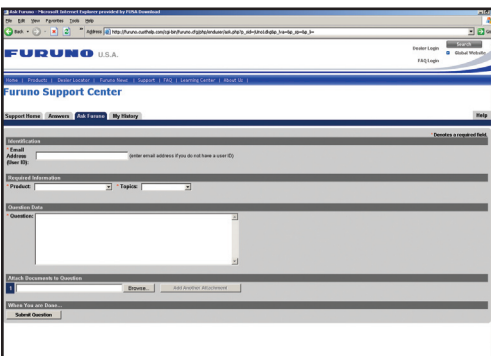
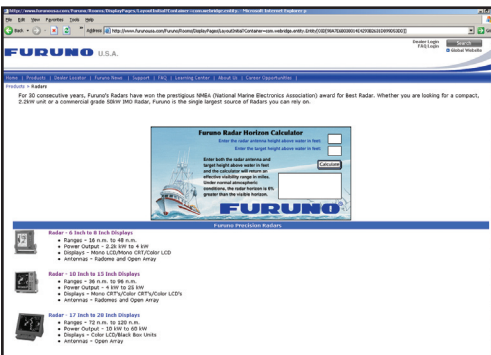

## Mark Display:

Table 2 describes the marks commonly found on Furuno Radars.

Mark	Appearance	Description
Cursor		The cursor is controlled by operating the trackball, arrow keys or omnipad. Its main function is to measure range and bearing to a target, select AIS and ARPA targets, and set guard zones
Tuning Bar		The tuning bar shows receiver tuning state. Normally, a longer bar indicates better tuning, however the length of the bar can vary with range and number of targets.
Heading Mark		The heading mark shows own ships heading. With no gyro or fluxgate compass the mark always points to zero degrees.
North Mark		This mark appears when a gyro or fluxgate compass is connected to the Radar. The short dashed line always points to north.
Range Rings		Range rings provide an estimate of range to target. The interval and number of rings may change with range.
VRM		Variable Range Marker. These marks appear on the display as dashed circles. The length of the dash of the #2 VRM is longer than that of the #1 VRM. They function to measure range to target.
EBL		Electronic Bearing Line. These marks appear on the display as dashed lines. The length of the dash on the #2 EBL is longer than that of the #1 EBL. They function to measure bearing to target.
Guard Zone		The guard zone defines an area which, when targets enter or leave as per user settings, an audible alarm is triggered to alert the user to the change.

### AIS Target Display:

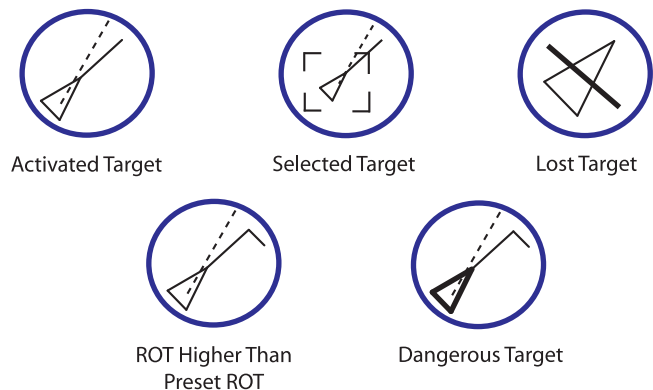

### ARPA Target Display:

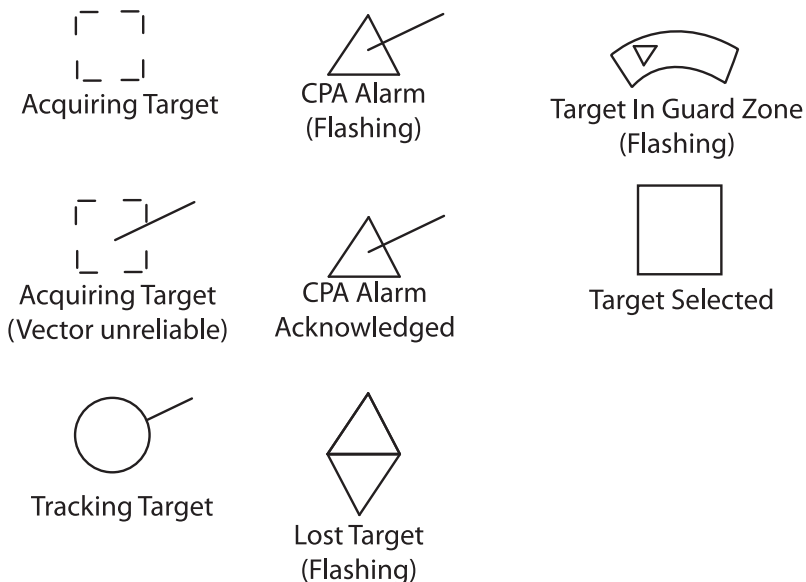

## 4. MAINTENANCE

Regular maintenance is important for continued performance of the Radar. Before reviewing this section, please read the safety information which follows.

### ***DANGER: ELECTRICAL SHOCK HAZARD***

This equipment uses high voltage electricity which can endanger human life. At several places within the unit there are high voltages sufficient to kill anyone coming in direct contact with them. While the equipment has been designed with consideration for the operators safety, precautions must always be exercised when reaching inside the equipment for the purpose of maintenance or service. For this reason, only qualified personnel totally familiar with electrical circuits and service manual should work inside the display or scanner units. A residual charge remains in capacitors and other devices for several minutes after turning off the power. Therefore, before beginning any maintenance work, wait for two or three minutes to allow the residual charge to subside.

PERIOD	ITEM
3 to 6 Months	Scanner unit fixing bolts and nuts are exposed to the marine environment and are thus subject to corrosion. Check bolts for tightness and corrosion, replacing any corroded bolts and coating new bolts with anticorrosion sealant.
	Foreign material such as salt deposits, oil, etc., can accumulate on the radiator (antenna) and cause a considerable drop in Radar performance. Wipe the radiator clean with a freshwater-moistened cloth. Because the radiator is constructed of reinforced plastic, do not use gasoline, benzine or any other commercial cleaners to clean the radiator as they can damage the integrity of the radiator and remove paint from its surface.
	Check the waterproofing gasket for wear. The gasket should be coated with silicone grease to preserve elasticity.
	Open the scanner unit and visually check that all screws on terminal board are secured tightly.
	Wipe the screen clean with a soft cloth to remove any dust. Do not use chemical cleaners to clean the screen as they may remove paint, markings and any anti reflective coating that may be on the screen.
6 Months to 1 Year	Check the scanner drive motor brushes. The life of these carbon brushes is about 2,000 hours. If their lengths are less than 6 mm, replace them with new brushes, which are 11 mm long.
	Carbon dust given off by the scanner drive motor brushes may fall into the slits of the timing disk. This may cause the sweep on the display to jump. Check the slits for carbon dust and foreign material.
1 Year	Check that all wiring on terminal boards is secure. Check that all plugs and jacks are properly seated.

Table 3 above outlines a suggested regimen of maintenance that you may follow to get the best performance from your Radar. Preventive maintenance greatly extends the life of the equipment. A maintenance program should be established and should at least include the items listed above.

# Pure Radar for the Radar Purist...

## Introducing the FR8002 Color Radar Series

*Tidewater Inc.'s "Miss Jane Tide" provides supply support to an offshore oil rig. Furuno has been Tidewater's electronics choice for GMDSS, AIS, Radar and more.*

### FR8002 RADAR SERIES

12.1" SVGA TRUE-COLOR LCD DISPLAY  
6kW/12kW OR 25kW OUTPUT POWER  
4' OR 6' OPEN ARRAY

### Unbeatable Furuno Radar Features!

- Superior short, medium and long range target detection
- 48 RPM antenna rotation (auto or manual) for reliable tracking of fast moving targets at close range
- Displays up to 100 AIS targets (may require optional interface for non-Furuno AIS receivers)
- Advanced Auto mode provides improved control and adjustment of Gain, Tuning, AC Rain/Sea
- RGB video output option for external display
- Easy operation with large buttons, programmable function keys, dedicated rotary controls & trackball
- Optional 10 target ARPA and hand-held remote control
- Operate in nautical miles, statute miles or kilometers
- Dual NMEA0183 ports allows for interfacing with GPS, Chart Plotter and Loran
- 12 VDC or 24 VDC for any output power or antenna configuration

RADAR FISH FINDERS SONAR NAVIGATION COMMUNICATION AUTOPILOTS SOFTWARE

[www.FurunoUSA.com](http://www.FurunoUSA.com)

# FURUNO