



WeatherStation® Instrument

Owner's Guide

Models: PB100, PB150



Record the serial number found on the WeatherStation® instrument.

Serial No. _____

Date of Purchase _____

Copyright © 2007, 2008 Airmar Technology Corp. All rights reserved.

Table of Contents

Introduction.....	4
Safety Instructions.....	5
Adding External Sensors.....	6
Choosing the Mounting Location.....	7
Tools & Materials.....	8
Installing.....	9
Cable Routing & Connecting.....	12
Connecting to a Converter.....	12
Connecting to a Combiner.....	14
Connecting to an NMEA 0183 Display.....	24
Maintenance & Updates.....	26
Where to Purchase Parts.....	26
Troubleshooting.....	27
Appendix A—How the WeatherStation Instrument Works.....	29
Appendix B—Technical Information.....	35
Acronyms & Glossary.....	36

IMPORTANT: Please read the Owner's Guide completely before proceeding with the installation.

Introduction

Thank you for purchasing the Airmar's ultrasonic WeatherStation® instrument. This exciting product is actually six different sensors in a single unit—without any moving parts. The compact housing is waterproof with a single removable cable. Data is output in digital NMEA 0183 format.

Functions of the WeatherStation Instrument

- Apparent wind speed
- Apparent wind direction
- Magnetic compass heading
- Air temperature
- Wind chill temperature
- Angle of vessel pitch
- Angle of vessel roll
- Barometric pressure
- Global Positioning System (GPS)
- Vessel speed over ground (SOG)
- Vessel course over ground (COG)
- True wind speed
- True wind direction
- Heading relative to true north
- True wind chill temperature
- True wind speed relative to water—requires speed-through-water input

WARNING

Do not use the WeatherStation instrument for your primary navigational device. The two-axis compass can give inaccurate readings when the vessel is pitching and rolling.

Safety Instructions

WARNING: Navigation Aid Only

The WeatherStation instrument is only an aid to navigation and should never be solely relied upon. It is not a replacement for traditional navigation aids and techniques. Only official government charts contain all the information needed for safe navigation.

WARNING: Correct Installation Important

The WeatherStation instrument must be installed and operated according to the instructions in this owners guide. Failure to do so could result in poor product performance, personal injury, and/or damage to the boat.

WARNING: Electrical Safety

The power supply voltage must be 12 VDC (± 3 VDC). Any other voltage may damage the WeatherStation instrument and/or result in fire, causing personal injury and/or damage to the boat.

WARNING: Installation Safety

Always wear safety goggles and a dust mask when installing to avoid personal injury.

CAUTION: Disassembly

Do not disassemble the sensor. Removing the screws from the WeatherStation instrument will damage the waterproof seal, thus voiding the warranty.

IMPORTANT: Compass Safe Distance

The compass safe distance for standard and steering compasses is 0.30m (1'). Observe this distance to prevent interference to a magnetic compass.

IMPORTANT: Battery

Use a separate battery from the engine-start battery to supply power to the WeatherStation instrument. Voltage drops may cause the unit to lose information and/or change operating mode.

Improve Course-Over-Ground and True Wind Readings

The WeatherStation instrument incorporates a two-axis compass. Significant errors can occur in the heading when the vessel is pitching and rolling. If there is an error in the heading, there also will be a corresponding error in the true wind direction.

The True Wind error can be minimized or eliminated by using Course-Over-Ground instead of the internal compass to make calculations. (COG heading data is obtained from the GPS.) For instructions, go to “Advanced Setup”, “True Wind Options” in the WeatherCaster program.

Accuracy can also be improved with the addition of an external three-axis compass. This external compass data will override the WeatherStation compass. Install a compass using an Airmar Combiner. Instructions are located in the section, “Connecting to a Combiner”.

Adding External Sensors

The WeatherStation instrument can receive data from external sensors when they are connected through an optional Combiner. This device processes additional received data and transmits it to the WeatherStation instrument for use in true wind calculations. The WeatherStation instrument will automatically detect whether these sensors are internal, external, or not available at all. Simply connect the sensor(s) to the Combiner or other NMEA 0183 repeater hardware.

The data provided by an additional sensor(s) such as heading or water depth can also be seen on displays connected to the Combiner.

- **GPS**—An external NMEA 0183 GPS can be connected instead of or in addition to the internal GPS. The WeatherStation instrument gives priority to valid external GPS data when available.
- **Compass**—If an external electronic compass is installed and working, this external compass data will override the WeatherStation compass.
- **Speed-through-water sensor**—An external speed sensor with NMEA 0183 output can be installed, such as an Airmar Smart™ Sensor. Airmar recommends installing the DST800V to receive water depth, boat speed, and water temperature data.

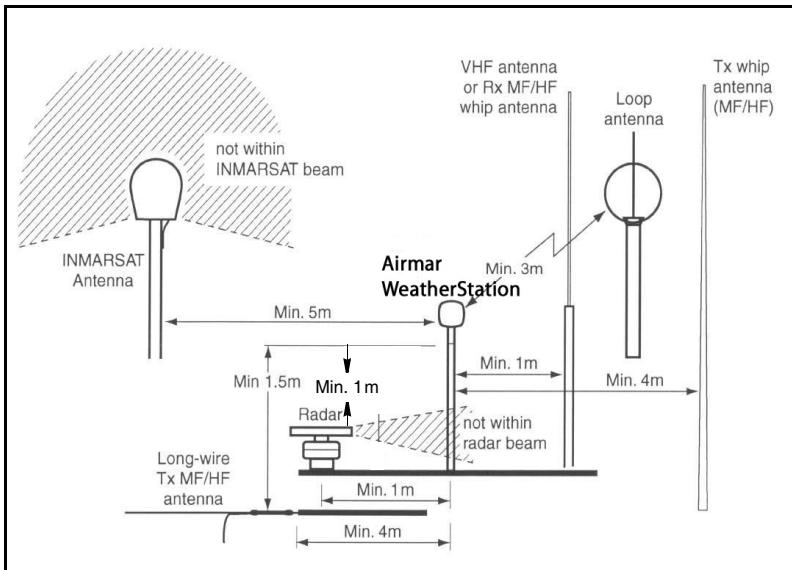

Figure 1. Antennas
 Courtesy of Northstar BNT, Acton, MA

Choosing the Mounting Location

For accurate readings and a reliable GPS signal, selecting the best location for the WeatherStation instrument is very important. Easy access and appearance should be secondary considerations. Since each installation is unique, the best separation distances from other equipment on the boat will vary depending on the particular equipment and how it is configured. Choose a location that balances the requirements below (see Figure 1).

- The WeatherStation instrument *must* be mounted in “clear air”—away from obstructions in any direction that will interfere with air flowing through the unit. If there is an obstruction, *be sure* to mount the WeatherStation instrument at least 2m (6') away. On land, avoid roof tops, chimneys, trees, etc.
- If possible, mount the WeatherStation instrument higher than any other object. Mount it a minimum of 500mm (20") above the surrounding surfaces. (Note that the higher the WeatherStation instrument is mounted, the less accurate the pitch and roll readings will be.)
- Because the WeatherStation instrument has an electronic compass, it should be at least 1m (3') away from any on-board radar equipment or other strong magnetic fields from equipment such as radio transmitters, boat engines, generators, etc.
- Because the WeatherStation instrument has a GPS, it *must* be lower than any on-board INMARSAT communications antenna.
- Because the WeatherStation instrument has a GPS, *be sure* it is as far as possible from high-powered transmitting antennas to avoid mutual interference.
- Because the WeatherStation instrument has a GPS, check for any electromagnetic shading. That is, any obstructions from other vessels or shoreline buildings that will interfere with the GPS signals that the WeatherStation instrument *must* receive.

Tools & Materials

Antenna mount with standard marine 1"-14 threads and pass-through for cable
(see Figure 2)

Hardware to install the antenna mount

Extension tube (optional)

Pencil

Level

Safety goggles

Dust mask

Electric drill

Drill bits

Phillips screwdrivers

Plumber's tape (optional)

Cutting pliers (some installations)

Wire strippers (some installations)

Electrical tape (some installations)

Converter (some installations)

Combiner (some installations)

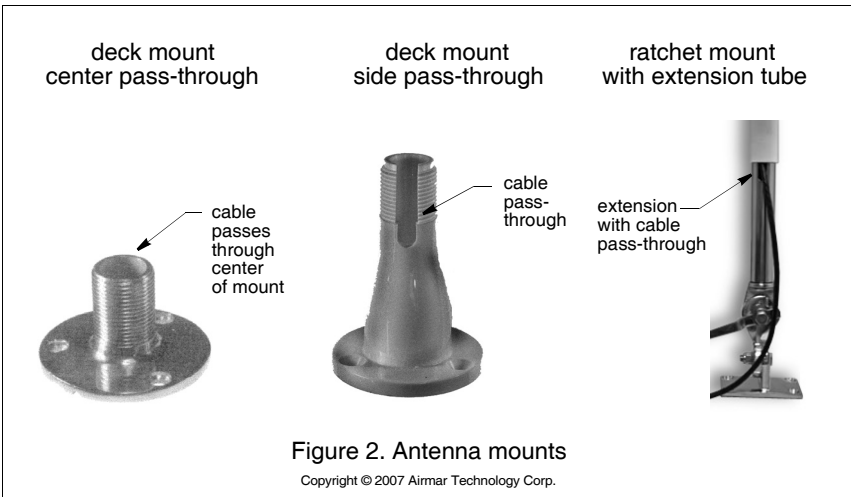

Where to Purchase

Gemeco (USA)

Tel: 843.394.3565

Fax: 843.394.3736

email: sales@gemeco.com

Airmar EMEA

Tel: 33.(0)2.23.52.06.48

(Europe, Middle East, Africa)

Fax: 33.(0)2.23.52.06.49

Email: sales@airmar-emea.com

Installing

WARNING: Always wear safety goggles and a dust mask.

CAUTION: The blue metal plate and the blue film found in the wind channel of the WeatherStation instrument are essential to its operation (see Figure 3). Be careful not to scratch the plate, puncture the film, or damage them in any way.

CAUTION: Do not remove the waterproof connector(s) to ease cable routing. If the cable must be cut and spliced, use Airmar's splash-proof Junction Box No. 33-035 and follow the instructions provided. Cutting the cable or removing the waterproof connector(s), except when using Airmar's junction box, will void the sensor warranty.

CAUTION: The WeatherStation instrument must be installed vertically—NOT tilted to one side. If the WeatherStation instrument is tilted from the horizontal plane, it will introduce an error in the compass reading.

CAUTION: Be sure the alignment tabs on the WeatherStation instrument point forward toward the bow and parallel to the centerline of the boat. This is necessary to accurately measure wind direction and vessel heading.

CAUTION: Do not tighten or align the WeatherStation instrument by rotating the upper cap (see Figure 3). Turning may sever internal connections and void the warranty. Grasp the lower housing below the blue metal plate. Hand-tighten only.



Figure 3. Wind channel

Copyright © 2008 Airmar Technology Corp.

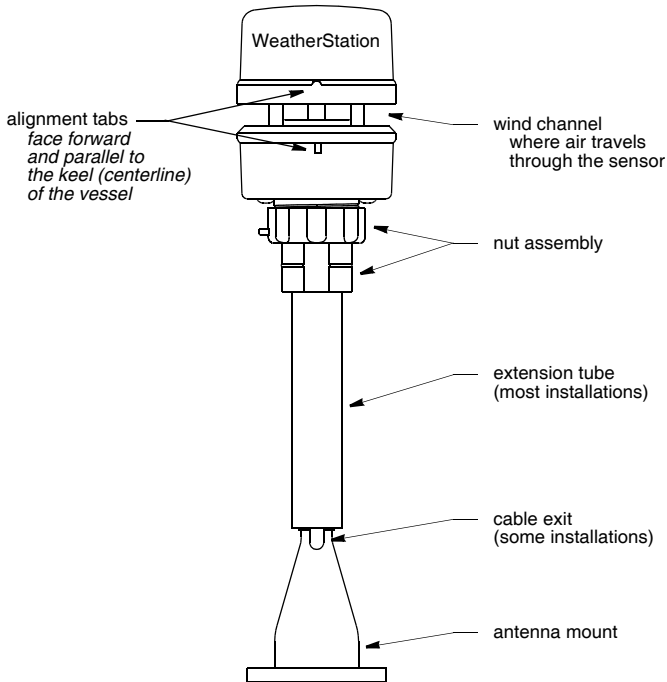

Figure 4. Installation

Copyright © 2008 Airmar Technology Corp.

1. Place the antenna mount at the selected location and mark the holes for the screws (see Figure 2). Also, mark the hole in the center of the mount for the cable to pass through. If you are using a ratchet mount, *be sure* you have purchased an extension with a cable pass-through.
2. Position the antenna mount at a 90° angle to the deck. If necessary, use shims to make the mounting surface level (see Figure 4).

WARNING: Always wear safety goggles and a dust mask.

3. Drill the holes for the mounting screws and the cable exit if necessary.
4. Using purchased screws, fasten the antenna mount in place.
5. Screw an extension tube onto the antenna mount if desired.

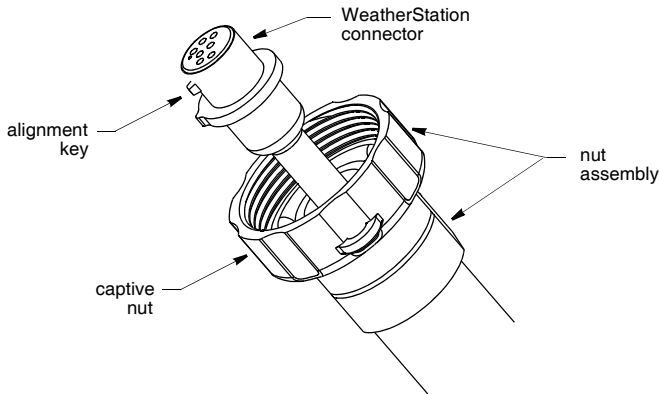

Figure 5. Connector
 Copyright © 2008 Airmar Technology Corp.

6. With the nut assembly on the cable near the WeatherStation connector, thread the cable through the extension tube (if used), antenna mount, and the cable exit. Allow several inches of cable topped by the connector above the nut assembly (see Figure 5).

CAUTION: If you use a thread lock, use plumber's tape. Do not use a liquid thread lock as it may weaken the plastic, causing it to swell and crack.

7. Screw the nut assembly onto the top of the antenna mount/extension tube.
Hand-tighten only. Do not over tighten.
8. Remove the caution label from the WeatherStation instrument's socket. Remove the protective cover from the connector. (Save the cap to protect the connector, when the WeatherStation instrument is removed.) Plug the 7-pin connector into the WeatherStation instrument. The alignment key on the connector fits into a notch in the base of the WeatherStation instrument.
9. *Be sure* the alignment tabs on the WeatherStation instrument are facing forward and parallel to the keel (centerline) of the boat (see Figure 4). Slide the captive nut upward and screw it onto the base of the WeatherStation instrument (see Figure 5). **Hand-tighten only.** Do not over tighten. *Be careful NOT* to rotate the WeatherStation instrument or loosen the nut assembly from the antenna mount/extension tube. *Double check to be sure* the alignment tabs are still facing forward.

Cable Routing & Connecting

Depending on the equipment that you will be using, route the WeatherStation cable to a Converter, a Combiner, or directly to an NMEA 0183 display. You must read the safety instructions below before going to the section that is appropriate for your equipment.

WARNING: Always wear safety goggles and a dust mask.

WARNING: The power supply voltage must be 12 VDC (± 3 VDC).

WARNING: The power panel must have a 1 amp fast-blow fuse or circuit breaker.

CAUTION: Do not remove the waterproof connector(s) to ease cable routing. If the cable must be cut and spliced, use Airmar's splash-proof Junction Box No. 33-035 and follow the instructions provided. Cutting the cable or removing the waterproof connector, except when using Airmar's junction box, will void the sensor warranty.

CAUTION: To reduce electrical interference, separate the cables from other electrical wiring and the engine.

CAUTION: Be careful not to tear the cable jackets when passing them through bulkheads and other parts of the boat. Use grommets to prevent chaffing.

CAUTION: Use a multimeter to check the polarity and the connections to the 12VDC power supply before applying power to the sensor.

CAUTION: Coil any excess cable(s) and secure it with a zip-tie to prevent damage.

Connecting to a Converter

The Converter allows the WeatherStation measurements to be displayed on a PC by converting the data from NMEA 0183 to USB.

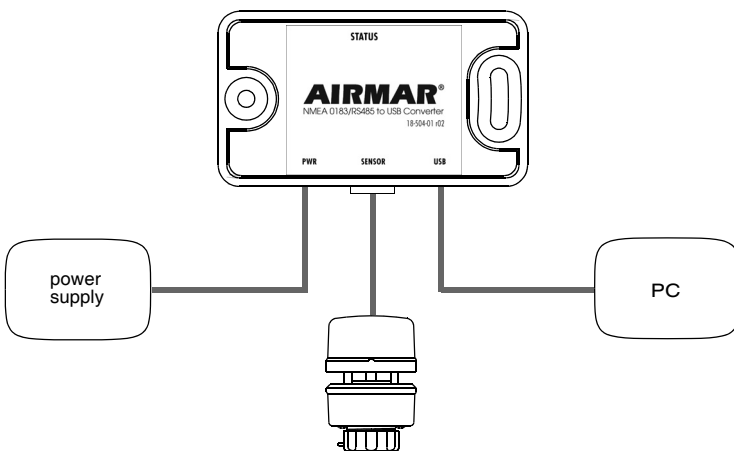

Figure 6. Converter installation

Copyright © 2007 Airmar Technology Corp.

Mounting Location of the Converter

1. Select a convenient, dry, mounting location for the water-resistant Converter, a minimum of 1 m (3') from the PC (see Figure 6).
2. Hold the Converter at the selected location and mark the position of the screw holes. If the Converter will be mounted on a vertical surface, face the cables downward to avoid water seeping into the box.

WARNING: Always wear safety goggles and a dust mask.

3. At the marked locations, drill the holes for the screws. *Do not* fasten the Converter in place at this time.

WeatherStation Cable

Route the WeatherStation cable to the Converter. *Do not* connect the WeatherStation cable or fasten it in place at this time.

USB Cable

Route the USB cable coming from the Converter into the USB port on the PC. *Do not* connect the cable or fasten it in place at this time.

Power Cable

1. Route the power cable from the Converter to the power supply. *Do not* fasten the power cable in place at this time.
2. Allowing an extra 25cm (10") for wiring ease, cut the cable to length.
3. Strip 60mm (2-1/2") of the outer jacket and foil shielding from the cut end of the cable.
4. Cut off the bare wire flush with the cable jacket.
5. Strip 10mm (3/8") of conductor insulation from the end of each colored wire.
6. Protect the cable's foil shielding from causing a short by using heat-shrink tubing around the jacket where the wires emerge from the cable. The tape *must* overlap the wires a minimum of 6mm (1/4").
7. Connect the wires to the power supply [12VDC (\pm 3VDC) @ 0.5 amp required].

See the color code below.

Red	12 VDC +
Black	12 VDC -/ground

Note: *the Converter is powered by the USB port and the WeatherStation instrument is powered by the power cable.*

Completing the Installation

1. Fasten the Converter in place with the screws supplied.
2. Plug the WeatherStation cable into the Converter.
3. Plug the USB cable into the PC.
4. Fasten all the cables in place.

LED Indicator Light

The green LED indicator light will flash when the Converter is operating.

Installing the Software

Follow the instructions in the WeatherCaster™ Software Guide.

Connecting to a Combiner

The Combiner allows the WeatherStation data to be displayed simultaneously on both an NMEA display and a PC. On the Combiner, the two auxiliary grommets labeled AUX NMEA OUT can be used to connect additional devices capable of displaying WeatherStation data (see Figure 7). All display devices *must* be NMEA 0183.

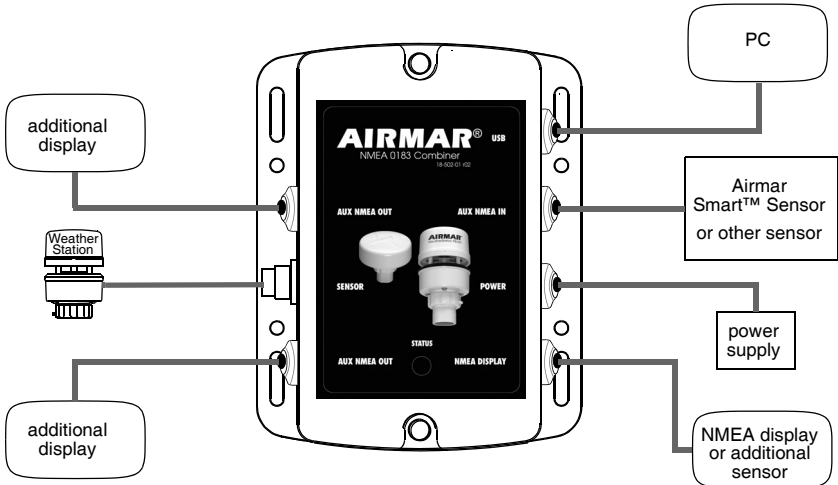

Figure 7. Combiner installation

Copyright © 2007 Airmar Technology Corp.

What does NMEA IN and NMEA OUT mean?

NMEA IN represents *input* for data flowing into an NMEA device. An IN device is an NMEA listener. NMEA OUT signifies *output* for data flowing out of a device. OUT devices are NMEA talkers. The Combiner label *designates data flow as viewed by the device itself*. For example, the Combiner's *output* should be connected to a display's *input*.

The *output* of any NMEA device (talker) may connect to the *inputs* of *multiple devices* (listener). However, it is not permissible to connect the *output* of one NMEA device to the *output* of another. If the need arises to provide data from the outputs of two or more devices to the input of a given device, then a Combiner is required.

CAUTION: Be sure to connect an NMEA talker to the NMEA IN terminal and NMEA listeners to the NMEA OUT terminals.

CAUTION: When connecting NMEA devices to one another, the cable shield only connects at **ONE** end of the cable, preferably at the device providing the NMEA output.

Mounting Location of the Combiner

1. Select a convenient, dry, mounting location for the water-resistant Combiner, a minimum of 1 m (3') from the NMEA device and the PC.
2. Hold the Combiner at the selected location and mark the position of the screw holes. Note—If the Combiner will be mounted on a vertical surface, face the grommets to the sides to avoid water seeping into the box.

WARNING: Always wear safety goggles and a dust mask.

3. At the marked locations, drill the holes. *Do not* fasten the Combiner in place at this time.

WeatherStation Cable

Route the WeatherStation cable to the Combiner. *Do not* connect the WeatherStation cable or fasten it in place at this time.

USB Cable

Route the USB cable coming from the Combiner to the USB port on the PC. *Do not* connect the cable or fasten it in place at this time.

NMEA Display/Additional Sensor Cable

1. Route the cable coming from the NMEA display/additional sensor to the Combiner. *Do not* fasten the cable in place at this time.
2. Allowing an extra 25 cm (10") for wiring ease, cut the cable to length.
3. Remove the cover of the Combiner to expose the terminals inside (see Figure 8).

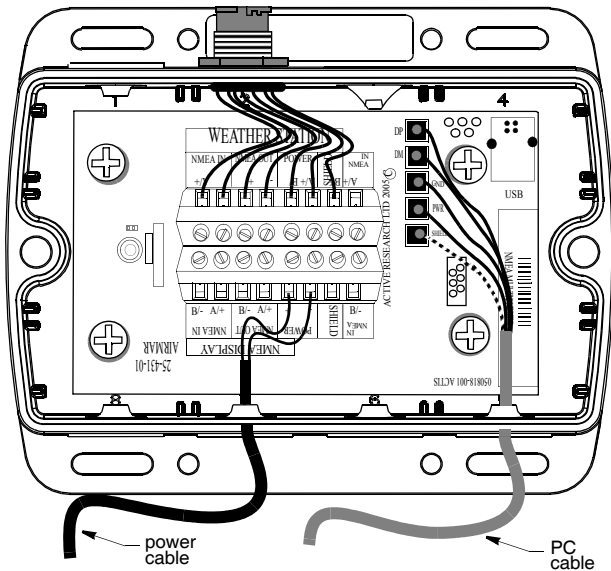

Figure 8. Inside a Combiner
Copyright © 2007 Airmar Technology Corp.

- Using a small Phillips screwdriver, puncture the grommet that corresponds to NMEA Display on the cover (see Figure 7). *Be careful* not to damage the circuit board.
- Push approximately 100mm (4") of the cable through the grommet (see Figure 9). To ease sliding, apply alcohol to the cable jacket.

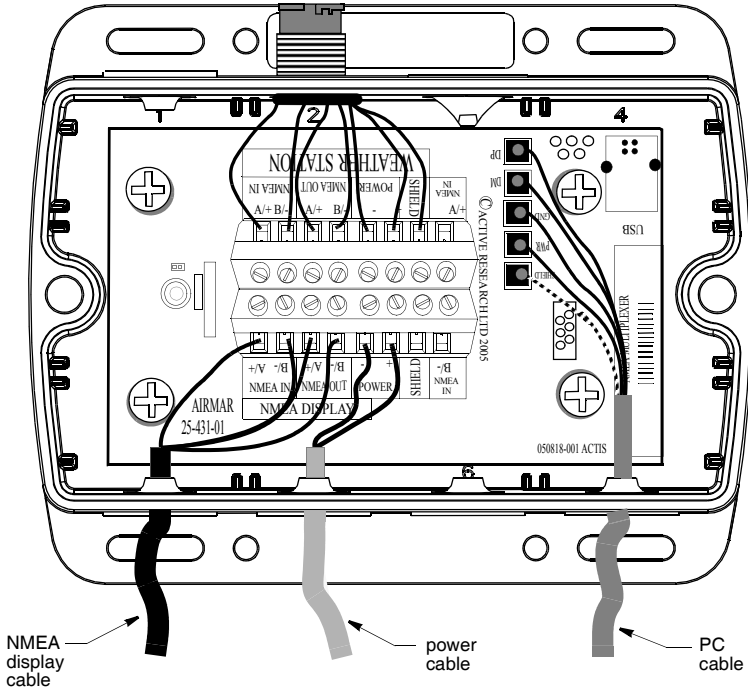

Figure 9. Wiring an NMEA display to a Combiner

Copyright © 2007 Airmar Technology Corp.

- Strip 60mm (2-1/2") of the outer jacket and foil shielding from the cut end of the cable.
- Strip 10 mm (3/8") of conductor insulation from the end of each colored wire.
- Protect the cable's foil shielding from causing a short by using heat-shrink tubing around the jacket where the wires emerge from the cable. The tape *must* overlap the wires a minimum of 6 mm (1/4").
- From outside the Combiner, *carefully* pull the cable until only 13mm (1/2") of the cable jacket remains inside.

10. Connect each wire in turn into the designated NMEA Display terminal. Loosen the screw, insert the stripped end of the wire into the square hole, and retighten the screw. *Be sure the stripped end of the wire is inserted up to its insulation only. Do not include any insulation inside the terminal.* Gently tug on the wire to ensure that it is securely fastened. Repeat this process until all the wires are connected. Refer to the owner's manual that came with the display/sensor and the wiring diagram below (see Figure 10).

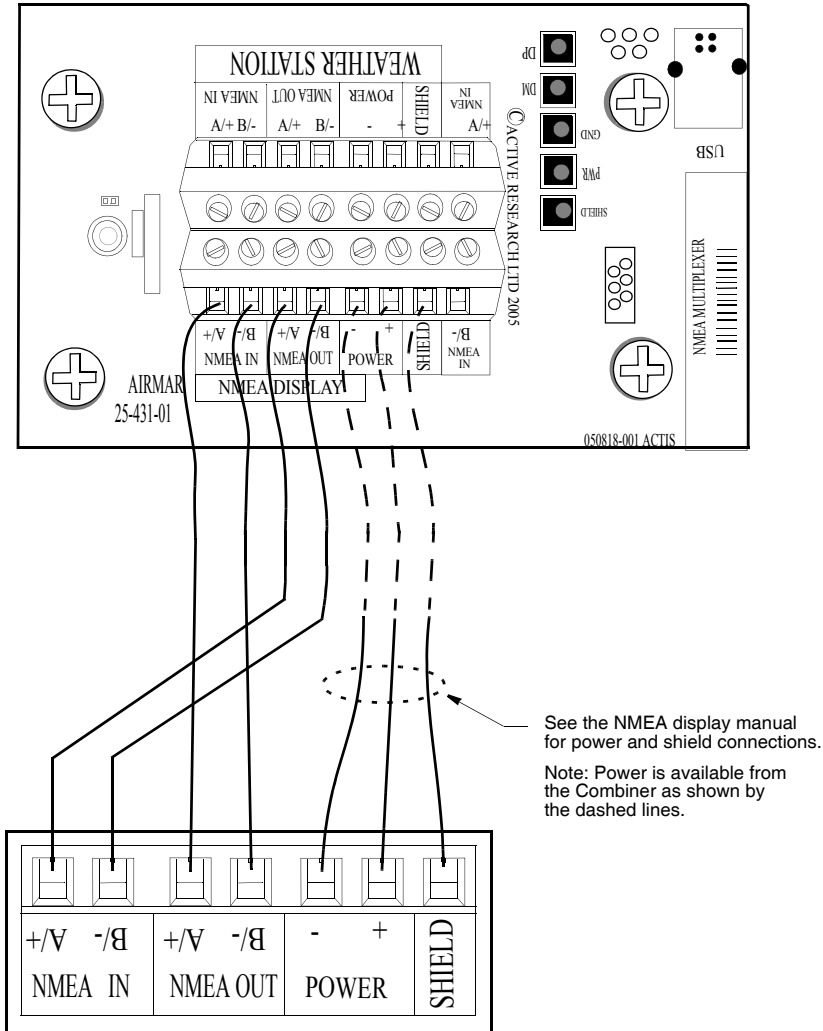

Figure 10. Wiring diagram to connect an NMEA display

Copyright © 2007 Airmar Technology Corp.

Auxiliary NMEA IN Grommet

Use the AUX NMEA IN grommet to connect an external NMEA 0183 sensor such as: an Airmar Smart™ Sensor, an external GPS, an external compass, or other sensor. An “IN” device will supply additional data to the WeatherStation instrument.

The WeatherCaster software will automatically detect a Smart Sensor and display the appropriate data. Airmar recommends installing the DST800V to receive water depth, boat speed, and water temperature data. Other Smart Sensors can be connected, provided that your NMEA display can read the sentence output and is configured to display those values.

The AUX NMEA IN grommet can also be used to connect an external GPS. In some cases, a GPS receiver can be plugged directly into an NMEA port on the display, if it can repeat the input to the Combiner. This would leave the AUX NMEA IN grommet on the Combiner free to connect an Airmar Smart Sensor.

To wire a device through the AUX NMEA IN grommet, use the NMEA IN terminals on the printed circuit board (see Figure 11).

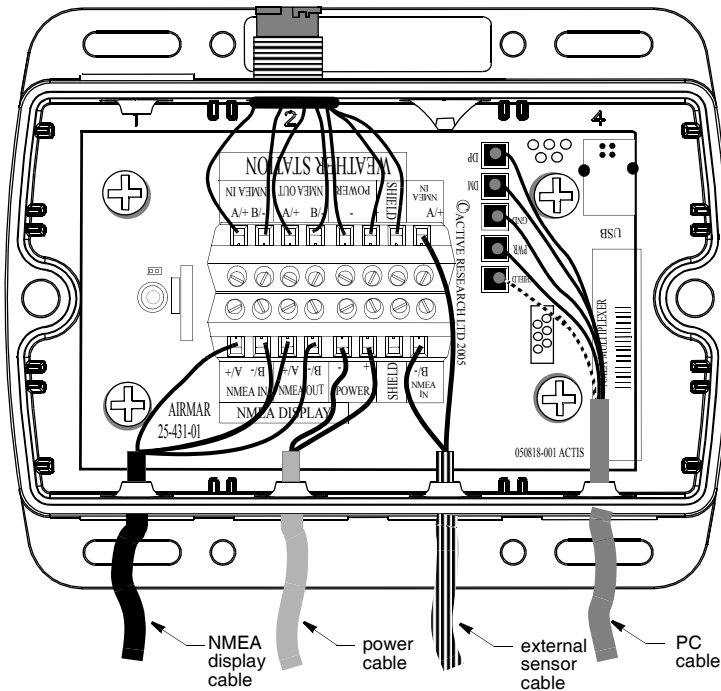

Figure 11. Wiring an external sensor to a Combiner

Copyright © 2007 Airmar Technology Corp.

1. Route the cable coming from the external sensor to the Combiner. *Do not* fasten the cable in place at this time.
2. Allowing an extra 25 cm (10") for wiring ease, cut the cable to length.
3. Remove the cover of the Combiner to expose the terminals inside (see Figure 11). Using a small Phillips screwdriver, puncture the grommet that corresponds to AUX NMEA IN on the cover (see Figure 7). *Be careful* not to damage the circuit board.
4. Push approximately 100mm (4") of the cable through the grommet (see Figure 11).
5. Strip 60 mm (2-1/2") of the outer jacket and foil shielding from the cut end of the cable.
6. Strip 10 mm (3/8") of conductor insulation from the end of each colored wire.
7. Protect the cable's foil shielding from causing a short by using heat-shrink tubing around the jacket where the wires emerge from the cable. The tape *must* overlap the wires a minimum of 6 mm (1/4").
8. From outside the Combiner, *carefully* pull the cable until only 13mm (1/2") of the cable jacket remains inside.

9. Connect each wire in turn into the designated NMEA IN terminal. Loosen the screw, insert the stripped end of the wire into the square hole and retighten the screw. *Be sure the stripped end of the wire is inserted up to its insulation only. Do not include any insulation inside the terminal. Gently tug on the wire to ensure that it is securely fastened. Repeat this process until all the wires are connected. Refer to the owner's manual that came with the sensor and the wiring diagram below (see Figure 12).*

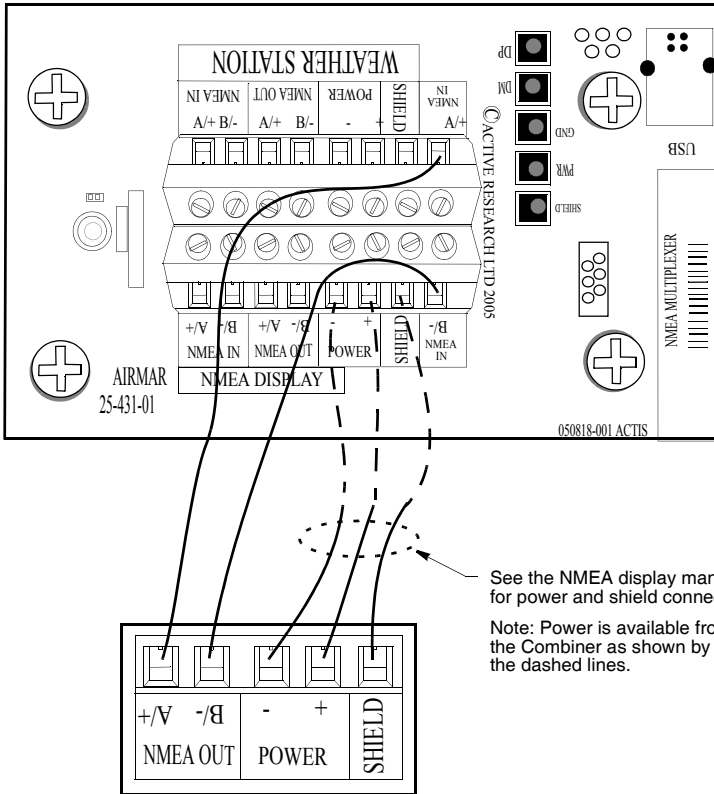

Figure 12. Wiring diagram to connect an external sensor

Copyright © 2007 Airmar Technology Corp.

Auxiliary NMEA OUT Grommets

Use the AUX NMEA OUT grommets to connect one or two additional devices to receive and display data from the WeatherStation instrument. To wire a device(s) through the AUX NMEA OUT grommet(s), use the NMEA OUT terminals on the printed circuit board (see Figure 13).

Note: If you will be connecting two devices, wire both devices to the same designated terminals—on top of one another.

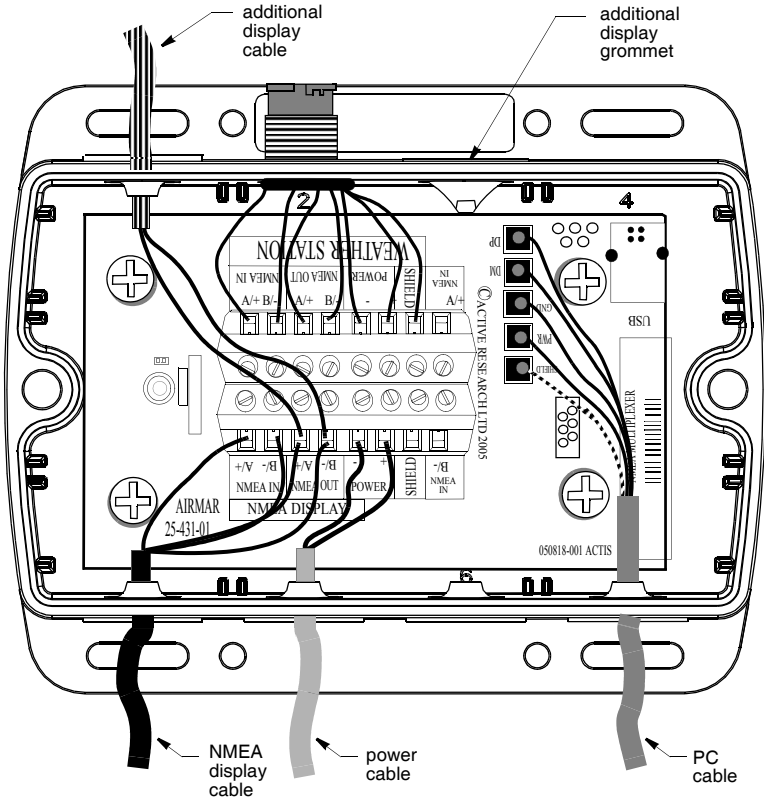

Figure 13. Wiring additional display devices to a Combiner

Copyright © 2007 Airmar Technology Corp.

1. Route the cable coming from the additional display device(s) to the Combiner. *Do not* fasten the cable in place at this time.
2. Allowing an extra 25 cm (10") for wiring ease, cut the cable to length.
3. Remove the cover of the Combiner to expose the terminals inside.
4. Using a small Phillips screwdriver, puncture the grommet(s) that corresponds to AUX NMEA OUT on the cover (see Figure 7). *Be careful* not to damage the circuit board.

5. Push approximately 100mm (4") of the cable through the grommet(s) (see Figure 13).
6. Strip 60mm (2-1/2") of the outer jacket and foil shielding from the cut end of the cable (s).
7. Strip 10 mm (3/8") of conductor insulation from the end of each colored wire.
8. Protect the cable's foil shielding from causing a short by using heat-shrink tubing around the jacket where the wires emerge from the cable. The tape *must* overlap the wires a minimum of 6 mm (1/4").
9. From outside the Combiner, *carefully* pull the cable until only 13mm (1/2") of the cable jacket remains inside.
10. Fasten each wire in turn into the designated AUX NMEA OUT terminal. Loosen the screw, insert the stripped end of the wire into the square hole and retighten the screw. *Be sure the stripped end of the wire is inserted up to its insulation only. Do not* include any insulation inside the terminal. Gently tug on the wire to ensure that it is securely fastened. Repeat this process until all the wires are connected. Refer to the owner's manual that came with the display/sensor and the wiring diagram below (see Figure 14).

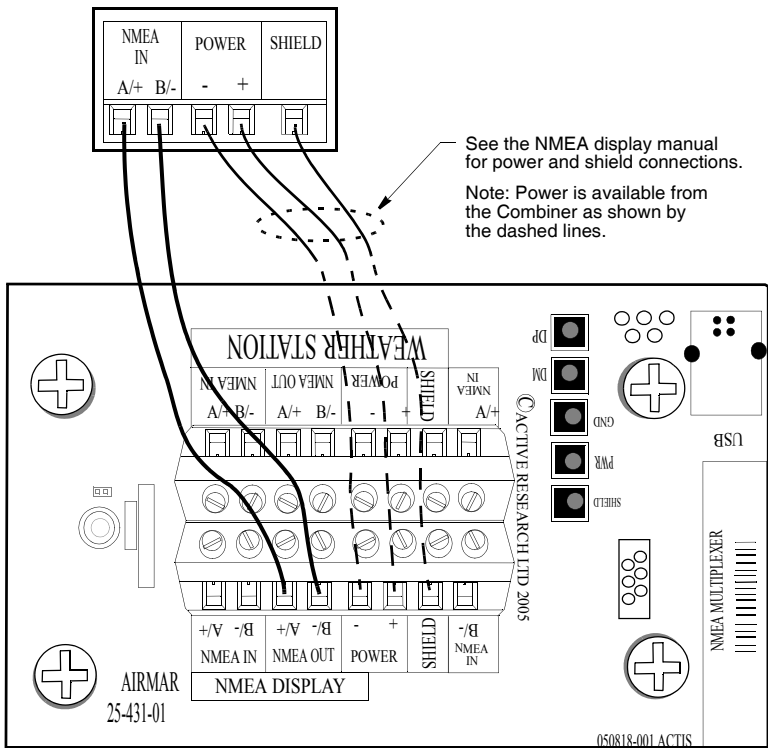

Figure 14. Wiring diagram to connect additional display devices
 Copyright © 2007 Airmar Technology Corp.

Power Cable

1. Route the power cable from the Combiner to the power supply (see Figure 13).
Do not fasten the cable in place at this time.
2. Allowing an extra 25cm (10") for wiring ease, cut the cable to length.
3. Strip 60mm (2-1/2") of the outer jacket and foil shielding from the cut end of the cable(s).
4. Cut off the bare wire flush with the cable jacket.
5. Strip 10mm (3/8") of conductor insulation from the end of each colored wire.
6. Protect the cable's foil shielding from causing a short by using heat-shrink tubing around the jacket where the wires emerge from the cable. The tape *must* overlap the wires a minimum of 6mm (1/4").
7. Connect the wires to the power supply [12VDC (\pm 3VDC) @ 0.5 amp required].
See the color code below.

Red	12 VDC +
Black	12 VDC -/ground

Completing the Installation

1. From outside the Combiner, carefully pull each cable until only about 13mm (1/2") of the cable *jacket* remains inside the box. This will invert the nipples to form a watertight seal.
2. Arrange the wires neatly inside the Combiner, *being sure* that no bare wires are touching.
3. Attach the Combiner cover with the screws provided.
4. Fasten the Combiner in place, using the screws provided.
5. Plug the WeatherStation connector into the designated WeatherStation port on the Combiner.
6. Plug the USB cable from the Combiner into the USB port on the PC.
7. Fasten all the cables in place.

LED Indicator Light

The green LED indicator light will be flashing when the Combiner is operating.

Installing the Software

Follow the instructions in the *WeatherCaster™ Software Guide*.

Connecting to an NMEA 0183 Display

1. Route the WeatherStation cable to the display. *Do not* fasten the cable in place at this time.
2. Connect the WeatherStation instrument to the display.
 - **Connector**—If your WeatherStation instrument came with a connector, and it can be plugged into the port on your NMEA 0183 display, do so now. Coil any excess cable and secure it with a zip-tie to prevent damage. Fasten the cable in place.
 - **No connector**—If your WeatherStation instrument does not have a connector on the display end, it *must* be hard wired. Refer to the owner's manual that came with your display and connect the colored wires as shown in the table below and Figure 15.

WeatherStation Function	WeatherStation Cable	Display Function
NMEA input A/+	Yellow	NMEA output A/+ (see Note 2)
NMEA input B/-	Orange	NMEA output B/-
NMEA output A/+	White	NMEA input A/+
NMEA output B/-	Blue	NMEA input B/-
12 VDC +	Red (see Note 1)	12 VDC + (see Note 3)
12 VDC -/ground	Black	12 VDC -/ground
Shield	Bare	Shield

Note 1: *The WeatherStation instrument must be supplied with 12 VDC+ (± 3 VDC) at 0.5 amp between the red and black leads.*

Note 2: *If your display does not have NMEA output connections, the yellow and orange wires are not needed and their ends should be taped separately. (Alternatively, yellow and orange wires can be connected to an external sensor.)*

Note 3: *The display power may be wired directly to the WeatherStation cable, or it may be wired separately.*

No Connector—Wiring

1. Allowing an extra 25 cm (10") for wiring ease, cut the cable to length.
2. Cut off the bare wire flush with the cable jacket.
3. Strip 10 mm (3/8") of conductor insulation from the end of each colored wire.
4. Protect the cable's foil shielding from causing a short by using heat-shrink tubing around the jacket where the wires emerge from the cable. The tape *must* overlap the wires a minimum of 6 mm (1/4").
5. Connect the wires to the display (see Figure 15).
6. Fasten all cable in place.
7. Your installation is complete. To begin receiving weather readings, refer to the owner's manual that came with your display.

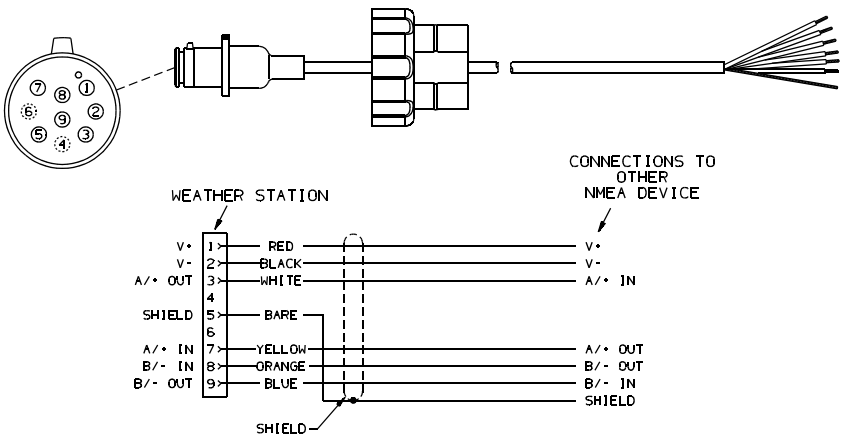

Figure 15. Wiring diagram to connect to an NMEA display

Copyright © 2007 Airmar Technology Corp.

Maintenance & Updates

Software Updates

Periodically, Airmar will release updated versions of both the WeatherStation firmware and the WeatherCaster software. Updates can be downloaded from Airmar's web site, www.airmar.com, or contact Airmar's technical support personnel for a CD.

Calibration

The WeatherStation instrument is calibrated at the factory and does not require any calibration after purchase.

Maintenance

Since the WeatherStation instrument has no moving parts, it requires minimal maintenance.

CAUTION: The blue metal plate and the blue waterproof film found in the wind channel of the WeatherStation instrument are essential to its operation (see Figure 16). The blue waterproof film protects the transducers, so be careful to keep it intact. Do not to scratch the metal plate or damage it in any way.

IMPORTANT: Keep the wind channel free of *SPIDER WEBS*, insects, dirt, and other debris.

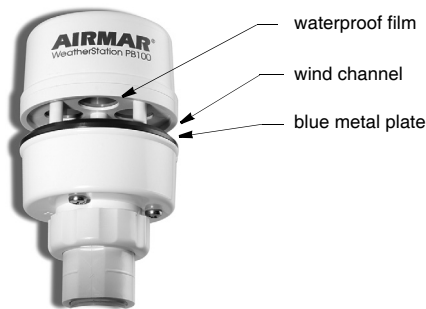

Figure 16. Wind channel

Copyright © 2007 Airmar Technology Corp.

Where to Purchase

Gemeco (USA)

Tel: 843.394.3565

Fax: 843.394.3736

email: sales@gemeco.com

Airmar EMEA

(Europe, Middle East, Africa)

Tel: 33.(0)2.23.52.06.48

Fax: 33.(0)2.23.52.06.49

Email: sales@airmar-emea.com

Troubleshooting

No Readings or Inaccurate Readings

- Is there power to the WeatherStation instrument?
- Are all the connections tight?
- Is the cable-run free of kinks?
- Is the wiring correct?
- Are there any obstructions in the wind channel of the WeatherStation instrument? Keep it free of *spider webs*, insects, dirt, and other debris. *Be careful not to puncture the blue waterproof film or scratch the blue plate.*
- Is there ice on the WeatherStation instrument?

No GPS Fix

- Does the WeatherStation instrument have a clear view of the sky?

Wind Readings Are Too Low

- Is the WeatherStation instrument mounted forward and low on the boat's hardtop in dead air? Move the instrument farther back and higher.

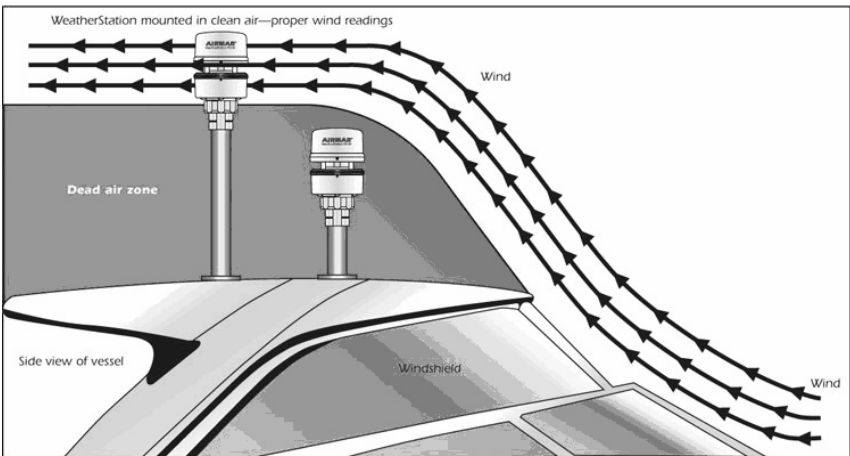

Copyright © 2007 Airmar Technology Corp.

Combiner Problems

The LED light on the Combiner indicates its current operating mode and if an error is detected during the self-test process. See the table below.

Color and Flash Count	Mode and Error Condition	Description of Mode and Required User Action
Red No flashing	Start-up mode No error	Normal operation mode that should last for no more than 1.5 seconds. Any longer indicates an error with the program. No action required.
Red No flashing	Flash Updating mode No error	The LED will stay red for the duration of the flash update operation. When the operation is complete, the Combiner will automatically reset. No action required.
Amber No flashing	Initialize & Self-test mode No error	Normal operation mode that follows the start-up mode and should last for approximately 1 second. No action required.
Green No flashing	Normal & No Data mode No error	Normal operation mode that follows the Initialize & Self-test mode. Indicates that no error was detected during self-test. Also, no data is currently being received by the Combiner. No action required.
Green Flashing (1–10 per sec.)	Normal & Data Receive mode No error	Normal operation mode that indicates data is being received by the Combiner. The flash rate is proportional to the Baud rate. No action required.
Amber Flashing (1 every 4 sec.)	Error Trap mode EEPROM memory error	An error with the EEPROM memory has been detected during the self-test mode. Reset the Combiner by powering down, waiting 60 sec., then restarting the Combiner.

PC Problems

If you are uncertain of the COM port on your PC, follow the steps below.

1. From the Start menu, select Control Panels.
2. Select the System option.
3. Select the Hardware tab.
4. Select Device Manager.
5. Select Ports.
6. Select Airmar NMEA 0183 – USB Converter.

The Converter is powered when it is connected to the USB port on the PC.

Appendix A—How the WeatherStation instrument Works About the Ultrasonic Wind Sensor

The ultrasonic wind sensor (an ultrasonic anemometer) measures apparent wind speed and direction. The WeatherStation instrument contains four ultrasonic transducers, visible through the four holes in the top of the sensor's wind channel (see Figure 17). These transducers operate in pairs—one transducer injects a pulse into the air. The pulse bounces off the metal plate at the bottom of the wind channel and is carried by the wind to arrive at the listening transducer a short time later.

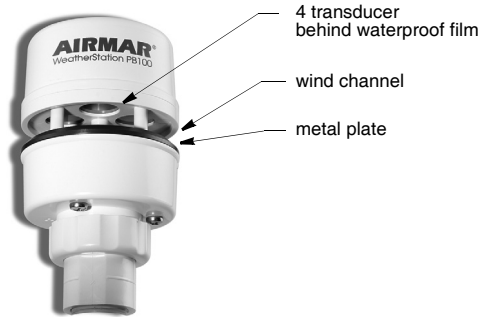

Figure 17. WeatherStation ultrasonic wind sensor
Copyright © 2007 Airmar Technology Corp.

When there is no wind, the pulse travels at the speed of sound from the sender to the receiver. Whenever the wind is blowing in that direction, the pulse will arrive sooner than if the air is still. Similarly, whenever the wind is blowing in the opposite direction, the pulse will arrive later than if the air is still. The four transducers take turns in sending and receiving pulses.

A microprocessor within the WeatherStation instrument then combines the measurements from all four transducers to calculate the resultant wind speed and direction. Throughout this process, the sensor monitors the air temperature, to compensate for the fact that the speed of sound in air changes with temperature.

Understanding True and Apparent Wind

The WeatherStation instrument has the unique ability to display both *true* and *apparent* wind. *True* wind is the actual motion of the air relative to the earth. *Apparent* wind is the wind which an observer experiences while moving or on board a boat. It is the result of two motions—the actual motion of the air (the true wind) and the motion of the boat. If the vessel is not moving, then the true and apparent wind will be the same.

There are two components to any wind measurement: speed and direction. By convention, the wind direction is an angle representing the direction *from* which the wind is blowing. Sometimes this angle is referenced to true or magnetic north, and sometimes it is referenced to the bow of the vessel. Both true and apparent wind use these same references.

Consider the case of a vessel proceeding at a speed of 15 knots in calm air. An observer on board would experience a wind of 15 knots from dead ahead. This *apparent* wind would be due solely to the motion of the boat. If a *true* wind of 15 knots was blowing from the stern, an observer would experience dead calm—no *apparent* wind. That is because the boat is moving at the same speed and in the same direction as the surrounding air.

Now, consider the more complicated situation of a vessel proceeding at 15 knots with a *true* wind of 15 knots blowing from the side (see Figure 18). To an observer on board, the *apparent* wind would be 21.2 knots blowing from an angle 45° off the bow.

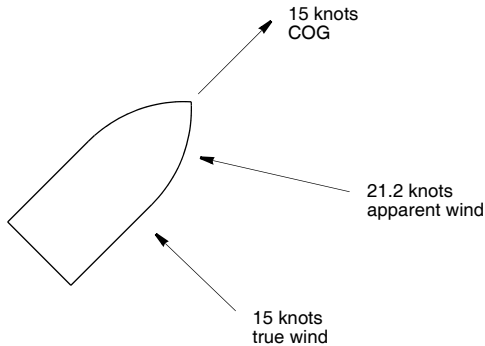

Figure 18. Apparent wind
Copyright © 2007 Airmar Technology Corp.

In order to calculate the true wind speed and direction when on board a moving vessel, it is necessary to know the apparent wind speed and direction, the speed and course over ground of the vessel, the compass heading, and the local magnetic variation. Note that heading and course are not the same thing: heading is the direction the bow of the vessel is pointing, while course is the direction the vessel is traveling. Heading and course may differ due to the effects of wind and current. The WeatherStation instrument can provide true wind speed and direction only if all of the data is available. The speed and course over ground must be provided by a GPS receiver—either built-in or networked. The heading may be provided by either the built-in electronic compass or by an external networked compass.

Because true wind is calculated using the data from several sensors, its accuracy depends on the accuracy of all the raw data used in the calculation. For instance, if the electronic compass is located near iron or a similar magnetic disturbance, the heading will be incorrect, and the true wind calculation will therefore be in error, perhaps by quite a bit. In another example, the speed and course over ground provided by the GPS receiver are averaged over time. If the boat is performing maneuvers, changing speed and/or direction, then it will take a few seconds for the SOG and COG values to "catch up". The reported true wind values will therefore also be incorrect until the vessel reaches a steady-state condition, traveling in a straight line at a constant speed.

About the Electronic Compass

The WeatherStation instrument includes a pair of magnetoinductive sensors that measure magnetic field strength in two axes on the horizontal plane of the WeatherStation instrument. From these measurements, it calculates the resultant magnetic heading angle, thereby providing a built-in electronic compass.

Like all magnetic compasses, the WeatherStation compass will be affected by any ferrous or magnetic materials in the vicinity, such as metal structures, motors, speakers, etc. It will also be affected by nearby electric fields, such as the wiring for navigation lights or radar domes. These nearby sources of magnetic interference will distort the magnetic field and produce errors in the compass heading. These errors are known as magnetic deviation.

Although the WeatherStation compass is a 2-axis device, the earth's magnetic field occurs in three dimensions. That is, part of the earth's magnetic field is oriented in the vertical direction. The closer one's location is to the north or south pole, the stronger this vertical component becomes in comparison to the horizontal components. The effect this has on the WeatherStation instrument is to introduce an error in the compass reading if the WeatherStation instrument is tilted from the horizontal plane. Therefore, it is important when installing the WeatherStation instrument to ensure the support pole is mounted vertically, and not tilted to one side. Also, keep in mind that when your vessel experiences pitch and roll, the compass heading will be affected accordingly.

Because the compass heading is used in the calculations for true wind, any errors in the compass heading will also produce errors in the reported true wind speed and direction.

If you have another electronic compass on board your vessel that is capable of providing the NMEA 0183 HDG sentence, you can connect the output from this external compass to the NMEA input on the WeatherStation instrument (or to the optional Combiner), and the data from the external compass will override the data from the built-in compass for the purpose of calculating true wind speed and direction.

About Magnetic Variation and True Heading

The earth acts like a giant magnet, with a magnetic north pole and a magnetic south pole. The axis of the magnetic poles is offset approximately 11.5° from the axis of the earth's rotation. Therefore, the earth's magnetic north and south poles are in different locations than the earth's geographic north and south poles. In addition, the earth's magnetic field is non-uniform, and changes over time. Magnetic variation, also known as magnetic declination, is the angle between magnetic north and true (or geographic) north, at the observer's current location.

A magnetic compass measures heading with respect to magnetic north. To convert this magnetic heading to true heading (that is, heading with respect to true north), the magnetic variation must be added to the measured magnetic heading value.

Because magnetic variation changes with location and gradually over time, it is necessary to calculate the magnetic variation using the user's present position and the current date. Therefore it is necessary to have a GPS with a fix in order to provide magnetic variation and heading with respect to true north.

About the Air Temperature Sensor

The WeatherStation instrument includes a built-in negative-temperature-coefficient thermistor that measures the ambient air temperature. This NTC thermistor is located in a thermally isolated region of the WeatherStation housing that is open to the outside air.

About Wind Chill Temperature

Wind Chill is a term that describes the heat loss on the human body resulting from the combined effects of low temperature and wind. As wind speed increases, heat is carried away from the body at a faster rate, causing a reduction in skin temperature. Because the face is the part of the human body that is most likely to be exposed, the wind-chill index is adjusted for the average adult face.

The concept of wind chill does not apply to inanimate objects, such as a boat. The only effect that wind chill has in this case is to shorten the time it takes the object to cool to the actual air temperature—wind chill does not cause an object to cool below that temperature. For example, fresh water freezes at 0°C (32°F) regardless of what the wind chill is.

The WeatherStation instrument calculates two values for wind-chill temperature: one using the apparent wind-speed, and one using the true wind-speed. The *apparent* wind-chill temperature is relevant to what an observer is currently experiencing on the vessel. The *true* wind-chill temperature indicates what the wind chill would be if the vessel were not moving.

Wind chill temperature is only defined for temperatures at or below 10°C (50°F) and wind speeds above 2.6 knots (3MPH).

By default, transmission of wind-chill data is disabled by the WeatherStation instrument. When used with WeatherCaster, the wind-chill data will be automatically enabled.

About the Barometric Pressure Sensor

The WeatherStation instrument contains a temperature-compensated, silicon, piezoresistive, pressure sensor. It measures atmospheric pressure for use as a digital barometer. While a single measurement of air pressure at a given location has little value, the trend of changing pressure and wind over time can be a useful tool in performing basic weather forecasting.

About the Global Positioning System

Some WeatherStation instruments have a built-in GPS with their own antenna, receiver, and position determining electronics. The GPS receiver receives radio signals from a constellation of orbiting satellites maintained by the U.S. government. By accurately measuring the time it takes for a transmission to travel from each satellite to the receiver, the unit is able to determine the distance between the satellite and the receiver. When the distance is known to three satellites, the unit is able to calculate the latitude and longitude of the receiver. This is known as a 2D fix. If the distance is known to four or more satellites, then the unit is additionally able to calculate the altitude of the receiver. This is known as a 3D fix.

The GPS receiver in the WeatherStation instrument takes approximately one minute on average to achieve a position fix after power is first applied. This is known as the "time to first fix."

The GPS receiver synchronizes itself to the atomic clocks on board each satellite. This allows the GPS receiver to accurately determine the date and time as well.

If the GPS receiver is mounted on a moving vessel, its changing position over time allows the speed and course over ground to be calculated. The course reported by a GPS is always with respect to true north.

The ability of the WeatherStation instrument to calculate true wind speed and direction depends on the presence of a GPS fix. If the GPS receiver is not tracking at least three satellites, then the WeatherStation instrument will be unable to provide true wind data. (Apparent wind data should always be available, regardless of the status of the GPS receiver.)

Certain models of the WeatherStation instrument do not include a built-in GPS receiver. In this case, if the true wind capabilities of the WeatherStation instrument are desired, it will be necessary to connect the output from an external NMEA 0183-capable GPS to the NMEA input on the WeatherStation instrument (or to the optional Combiner), in order to enable the true wind capabilities of the WeatherStation instrument.

Even if your WeatherStation instrument includes a built-in GPS receiver, you may wish to use a separate external GPS receiver instead, for the determination of true wind. If the WeatherStation instrument receives speed over ground and course over ground (SOG and COG) data on its NMEA input from an external GPS, these data will override the data from the built-in GPS for the purpose of calculating true wind speed and direction. In addition, the WeatherStation instrument will automatically suppress transmission of GPS messages from its own built-in GPS receiver.

About True Wind Relative to Water

If a fix from a GPS receiver is not available, it is still possible for the WeatherStation instrument to determine a value for true wind, if the speed of the vessel through the water is known. In this case, it is necessary that a water-speed sensor with an NMEA output (such as an Airmar Smart™ Sensor) be connected to the NMEA input on the WeatherStation instrument (or to the optional Combiner).

The WeatherStation instrument's calculation for true wind relative to water makes the significant simplifying assumption that the vessel's course is the same as its heading. That is, the effects of wind and current on the motion of the boat are ignored. The direction of the true wind relative to water is referenced only to the bow of the vessel, not to true or magnetic north.

Appendix B—Technical Information

Baud Rates

WeatherCaster needs to be set as follows:

- If you have a USB Converter, set the baud rate to 4800.
- If you have a Combiner, set the baud rate to 38400.

NMEA 0183 Sentence Commands

Datum Reference	\$GPDTM
GPS Fix Data	\$GPGGA *
Geographic Position L/L	\$GPGLL
Standard GNSS DOP and Active Satellites	\$GPGSA
Standard GNSS Satellites in View	\$GPGSV
Heading, Deviation, Variation	\$HCHDGL
Heading Relative to True North	\$HCHDT *
Meteorological Composite	\$WIMDA *
Wind Speed & Direction with respect to North	\$WIMWD *
Apparent Wind Speed & Direction with respect to bow	\$WIMWV(R) *
True Wind Speed & Direction with respect to bow	\$WIMWV(T)
Recommended Minimum GNSS	\$GPRMC
Course Over Ground (COG) & Speed Over Ground (SOG)	\$GPVTG *
True Wind Speed Relative to Water (speed sensor needed)	\$WIVWT *
Apparent Wind Speed and Direction	\$WIVWR
Wind Chill Temperature	\$WIXDR(A)
Pitch & Roll	\$WIXDR(B)
Date & Time	\$GPZDA *
Attitude	PFEC

* These sentences are enabled at the factory.

Additional Data Available from the WeatherStation Instrument

There are parameters that the WeatherStation can make available to the user. Usually, more data is available from the WeatherStation than can be displayed in a reasonable format on a screen. Also, if all the data was continuously transmitted to the display, the update rate would be too slow and could not keep up with WeatherStation measurements. Consequently, some parameters are transmitted while others are not, based on a pre-selected list (the NMEA 0183 sentences with an asterisk). Note that those parameters not transmitted are, nevertheless, retained in the WeatherStation. For more detailed information, see the “Technical Manual” on the WeatherStation CD.

Acronyms & Abbreviations

CD	Compact Disk
COG	Course Over Ground
COM Port	Communications Port
DOP	Dilution Of Precision
EGNOS	European Geostationary Navigation Overlay Service
GNSS	Global Navigation Satellite System
GPS	Global Positioning System
LED	Light Emitting Diode
PC	Personal Computer
SD	Satellite Differential
SOG	Speed Over Ground
UNS	Unified National Standard
USB	Universal Serial Bus
UTC	Universal Time Coordinated
WAAS	Wide Area Augmentation System
2D	Two Dimensional GPS Fix
3D	Three dimensional GPS Fix

Glossary

Firmware	The software within the WeatherStation hardware
WeatherCaster™ software	The PC application program

Trademarks

Airmar® is a registered trademark of Airmar Technology Corporation.

Smart™ Sensor is a trademark of Airmar Technology Corporation.

WeatherCaster™ is a trademark of Airmar Technology Corporation.

WeatherStation® is a trademark of Airmar Technology Corporation.

Windows® is a registered trademark of Microsoft Corporation.



35 Meadowbrook Drive, Milford, New Hampshire 03055-4613, USA
www.airmar.com