

CONTROL UNIT FSV-8401

3.6 kg 7.9 lb

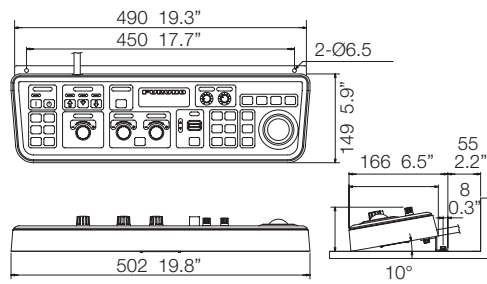

HULL UNIT FSV-8432/8442

800 mm: 350 kg 815.7 lb
1100 mm: 370 kg 859.8 lb

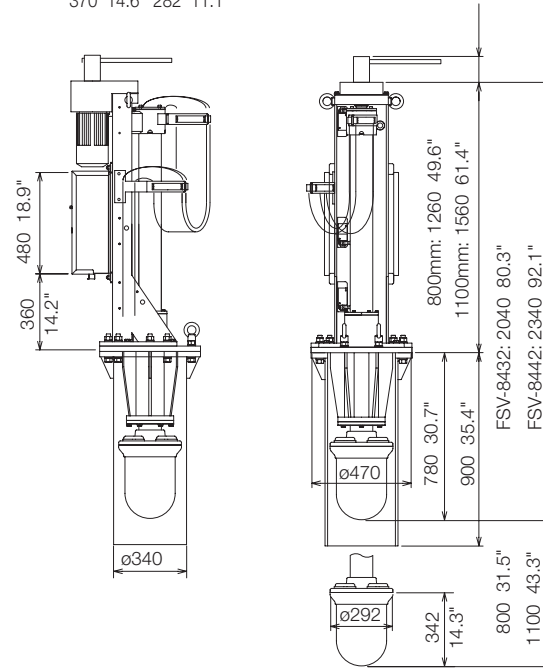
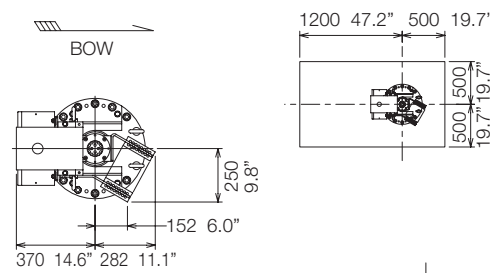

TRANSCIEVER UNIT FSV-841A

95 kg 209.4 lb

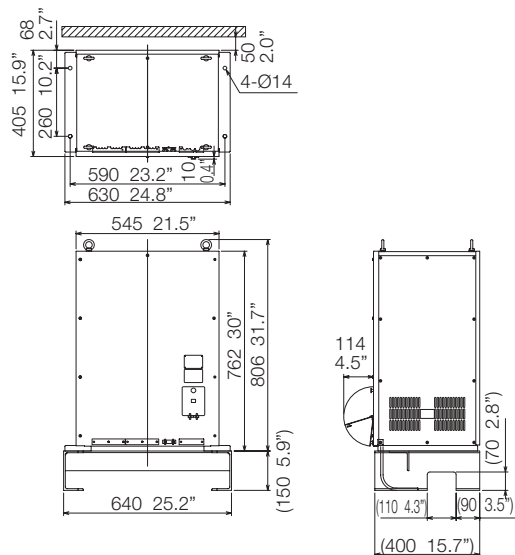

PROCESSOR UNIT FSV-8402

29 kg 63.9 lb

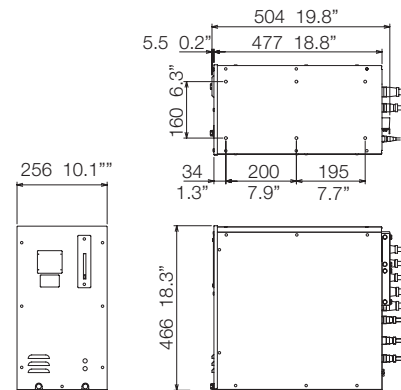

FULL-CIRCLE COLOR SCANNING SONAR
FSV-84

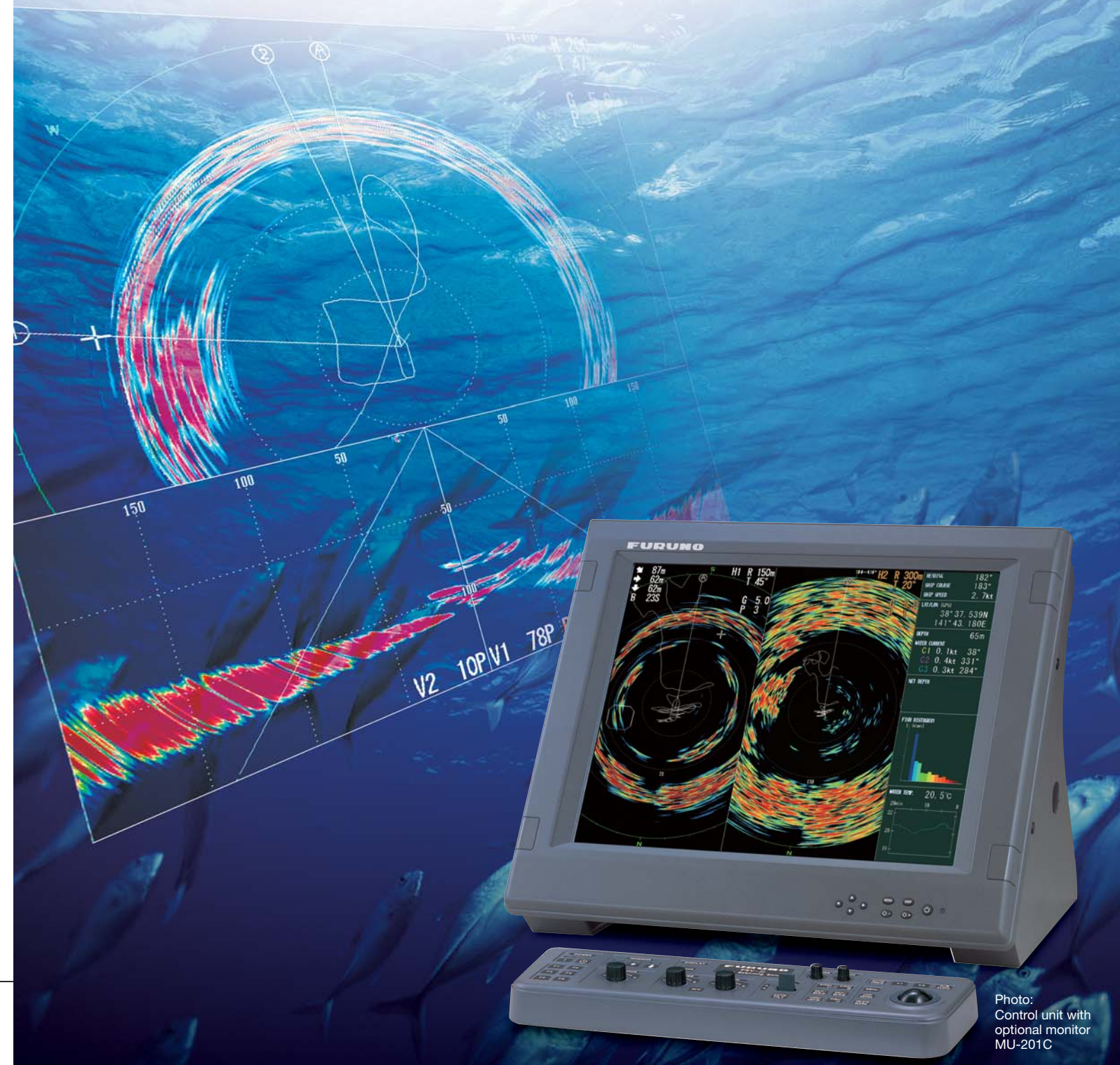

TRADEMARK REGISTERED
SPECIFICATIONS SUBJECT TO CHANGE WITHOUT NOTICE

FURUNO ELECTRIC CO., LTD.

Nishinomiya, Hyogo, Japan
Phone: +81 (0)798 65-2111
Fax: +81 (0)798 65-4200, 66-4622

FURUNO U.S.A., INC.

Camas, Washington, U.S.A.
Phone: +1 360-834-9300
Fax: +1 360-834-9400

FURUNO (UK) LIMITED

Havant, Hampshire, U.K.
Phone: +44 23 9244 1000
Fax: +44 23 9248 4316

FURUNO FRANCE S.A.S.

Bordeaux-Mérignac, France
Phone: +33 5 56 13 48 00
Fax: +33 5 56 13 48 01

FURUNO ESPAÑA S.A.

Madrid, Spain
Phone: +34 91-725-90-88
Fax: +34 91-725-98-97

FURUNO DANMARK AS

Hvidovre, Denmark
Phone: +45 36 77 45 00
Fax: +45 36 77 45 01

FURUNO NORGE A/S

Ålesund, Norway
Phone: +47 70 102950
Fax: +47 70 102951

FURUNO SVERIGE AB

Västra Frölunda, Sweden
Phone: +46 31-7098940
Fax: +46 31-497093

FURUNO FINLAND OY

Espoo, Finland
Phone: +358 9 4355 670
Fax: +358 9 4355 6710

FURUNO POLSKA Sp. z o.o.

Gdynia, Poland
Phone: +48 58 669 02 20
Fax: +48 58 669 02 21

FURUNO DEUTSCHLAND GmbH

Reilingen, Germany
Phone: +49 4101 838 0
Fax: +49 4101 838 111

LLC "FURUNO EURUS"

St. Petersburg, Russian Federation
Phone: +7 812 767 15 92
Fax: +7 812 766 55 52



07123U Printed in Japan
Catalogue No. E-404



Photo:
Control unit with
optional monitor
MU-201C

The groundbreaking 360-degree color scanning sonar from both shorter to longer range.

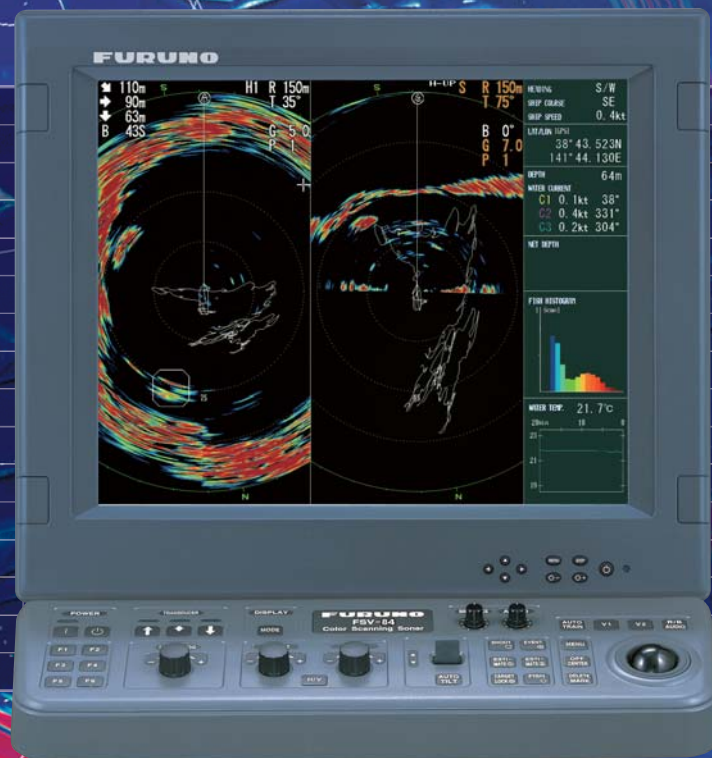

Photo:
Control unit with
optional monitor MU-201C

FULL-CIRCLE COLOR SCANNING SONAR FSV-84

The FSV-84 is a new full-circle color scanning sonar with a transducer having highly sensitive elements. It offers high resolution image in all ranges. Its detection range capability has been improved significantly compared to conventional scanning sonar utilizing an equal frequency.

A variety of presentation modes are available for efficient fishing operation in various fishing methods. Adding to conventional presentation modes such as full circle and vertical mode, FSV-84 offers Dual Full Scan mode which simultaneously shows two full-circle scans at different tilt angles or range, and Slant mode for 180-degree half-circle fan picture. Viewing from various perspectives, it helps to detect fish schools faster, to find more lucrative fishing grounds and to grasp the timing of the net shooting.

In addition, FSV-84 features advanced functions such as Auto Filter and a stabilization system for skippers to observe targets even in foul weather conditions. With its user-friendly interface, often-used functions can be enabled in one touch.

sonar provides high resolution images

▶ Auto Filter provides the clear view of targets

The Auto Filter enables stable observation of target even when the vessel is moving fast (under 18 knots). Additionally, the filter also reduces the influence of propeller noise and clutter from other vessels.

▶ Beam stabilization

The stabilizer keeps the beam on the designated target even in rough seas. The bottom and fish echoes are presented without undulation.

▶ Tracking a fish school (target lock)

The target lock function automatically tracks a fish school so you won't lose sight of it on the display. Two types of target lock are available: position tracking (TARGET MARK) and fish school tracking (FISH).

▶ User program control and six function keys

The user program control provides for instant setup of the equipment according to fishing ground or target fish. Ten programs may be set up, and vertical and horizontal display settings may be programmed together or individually. The function keys also provide one-touch display of desired menu item or entire menu.



10 User program control
6 function keys

▶ Customizable user menu

You may program 10 often-used menu items to the user menu area in the menu.

▶ Fish alarm

When a speaker (option) is connected, the fish alarm sounds the aural alarm if a fish echo above a preset strength enters the operator-set alarm zone.

▶ Built-in transceiver

A compact built-in transceiver with power unit allows simplified retrofitting.

▶ Utilizing common tank to conventional sonar

The transducer tank is common to the CSH-83 for reducing cost and time of installation.

* Convert kit needed

▶ Remote controlling and watching at upper bridge

Up to three display units can be installed anywhere (such as upper bridge) to monitor fish movement from remote locations. A remote controller is also available.

▶ Fish histogram

The fish histogram shows, in graph form, signal strength distribution for the fish school(s) marked with an estimate mark on the horizontal and echo sounder displays.

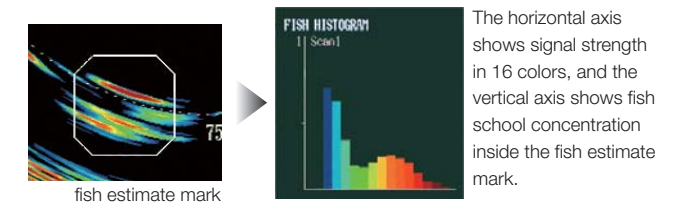

The horizontal axis shows signal strength in 16 colors, and the vertical axis shows fish school concentration inside the fish estimate mark.

▶ The innovative full-circle color scanning sonar designed for purse seiners and trawlers, ideal for mackerel and tuna detection

FSV-84's various and flexible presentation offers efficient fishing operation especially for purse seiners and trawlers. It offers skippers to evaluate fish schools both around and under the vessel, and to keep tabs on caught fish inside the net. The powerful high frequency sonar detects weak and fast moving targets even under harsh conditions.

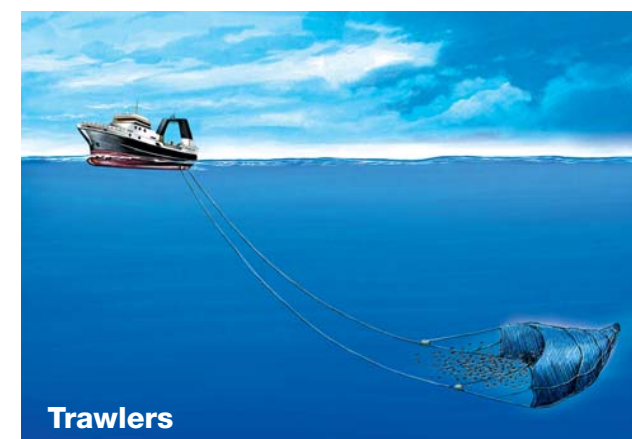

Trawlers

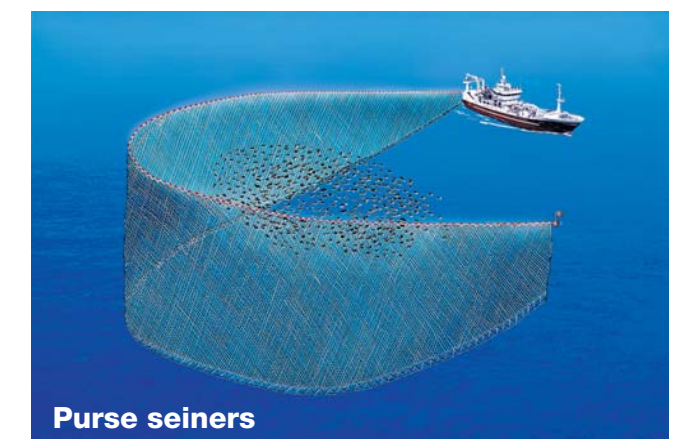

Purse seiners

Various display modes for a wide range of fishing applications

Dual full-circle scan

Full-circle scan can be set at the bearing of horizontally -5 degrees to 90 degrees under the vessel. Additionally, the dual full circle scan modes simultaneously show two full-circle scans at different tilt angles or range selected by the operator. The fish school shown on two images from far and near ranges permit skippers to conduct comparison between the two different targets. In other words, skippers can actually operate two sonar on one screen.

To enhance fishing operations, the images are presented in a variety of ways including dual-portrait, dual-landscape and inset modes.

Dual display (right and left)

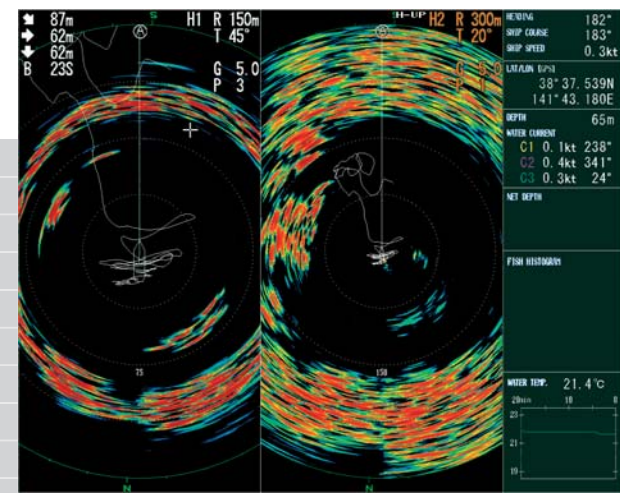

Horizontal scan 1

Range: 150 m
Tilt: 45
Gain: 5.0

Horizontal scan 2

Range: 300 m
Tilt: 20
Gain: 5.0

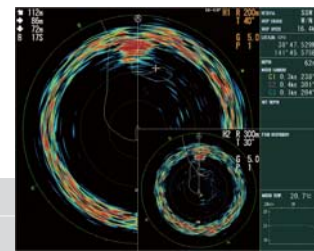
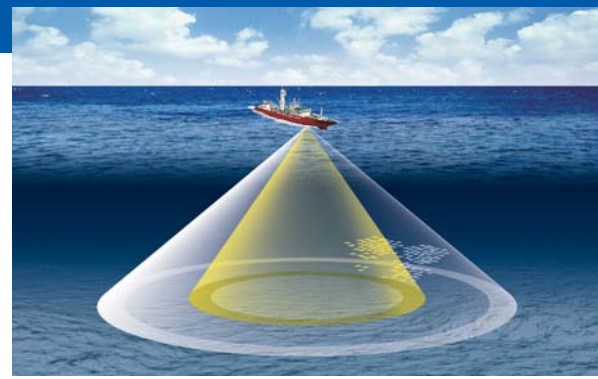

Inset display can be positioned right or left

Inset display mode

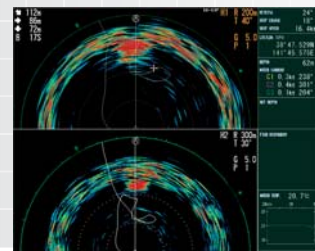

Landscape display mode

Combination of the full-circle and vertical scans

Adding to full-circle scan, the vertical scan can be displayed to show directional scan image of the selected bearing. The vertical scan setting can be simply done by just using the trackball to place the marker at desired location on the full-circle display, and press the designated key.

By utilizing both scans, the skipper can obtain location of a fish school and fish distribution in horizontal and vertical perspectives all the same time.

It is extremely helpful to grasp the spread of fish school or the most concentrated part of the target, as it is not necessary to go over the school to see the distribution on the echosounder.

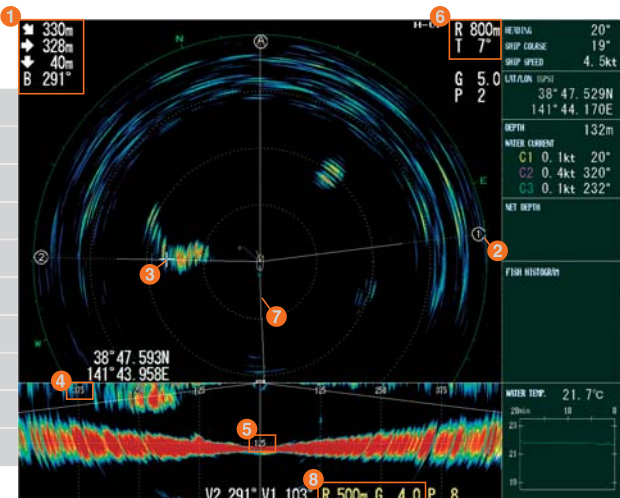
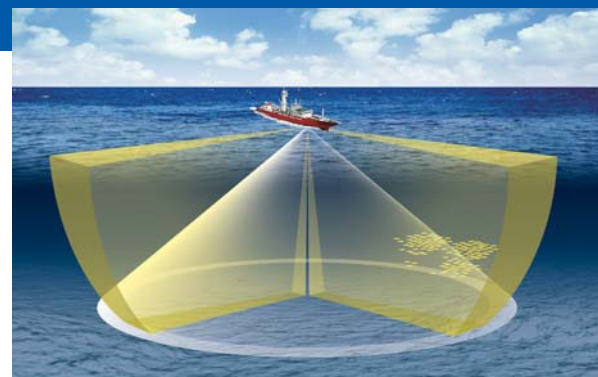

- 1 Direct distance, horizontal distance, water depth, and bearing to the cursor.
- 2 Bearing mark for vertical scan 1 (V1).
- 3 Cursor
- 4 Range distance of vertical scan
- 5 Water depth under the boat
- 6 Range, tilt, and display mode of Horizontal scan
- 7 Ship track
- 8 Range and gain of vertical scan

vertical scan 2

vertical scan 1

Slant mode scan

The Slant mode shows a 180-degree cross section, using chosen tilt angle and train setting. It is extremely useful for detecting bottom fish and monitoring changing bottom conditions, identifying the location of trawling activity. Purse seiners can also use this mode for observations of fish behavior and school structure in the net so that fish would not move away from the purse before catching. Moreover, sonar beam can be tilted to 90 degrees under the vessel and rotate 360 degrees, which can show scan image of the whole sea area around the vessel without any blind spot.

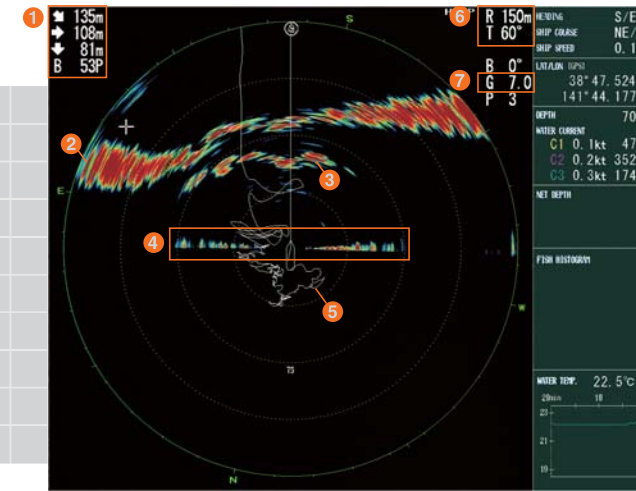
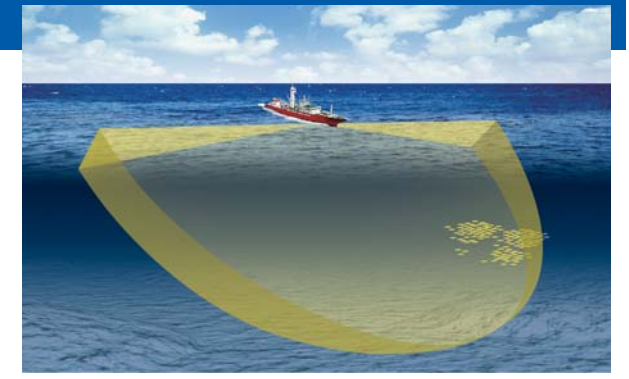

- 1 Direct distance, horizontal distance, water depth, and bearing to the cursor.
- 2 Seabed
- 3 Fish school
- 4 Sea clutter
- 5 Ship track
- 6 Range and tilt
- 7 Gain

Suppressing Bottom and Surface Reflection

In shallow fishing grounds with hard or rocky bottom, bottom reflections often interfere with wanted fish echoes and they can not be eliminated sufficiently with gain controls. In such cases, the output power can be reduced by adjusting the Tx output instead of turning down the gain. The picture becomes clearer when output power is reduced rather than when the GAIN is decreased as illustrated below.

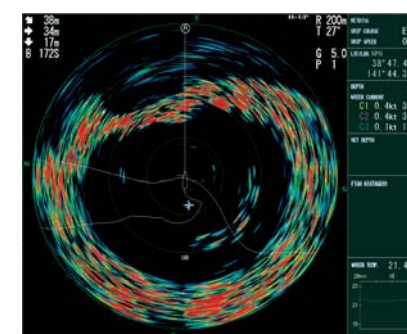
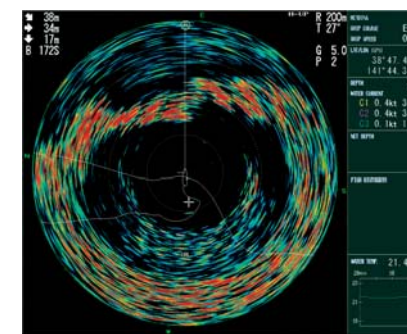

Beam Stabilization

Thanks to FSV-84's built-in motion sensor, the beam stabilization mode maintains the sonar beam at required tilt by compensating for ship's pitching and rolling. This gives an unwavering presentation of the echo images even in rough seas.

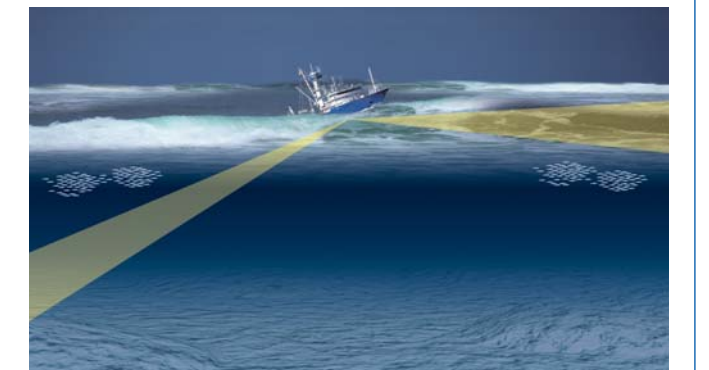

Stabilization OFF

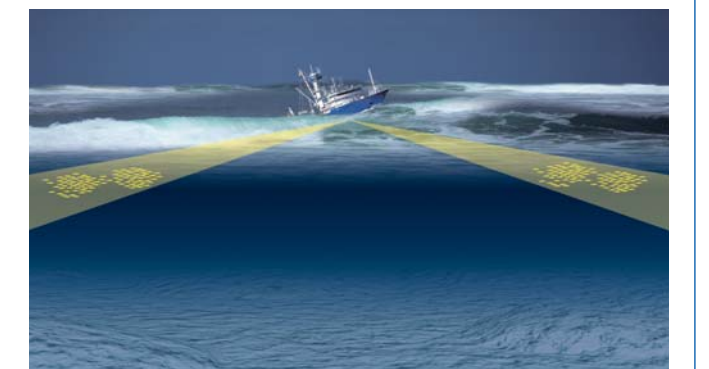

Stabilization ON

FSV-84 provides you the flexibility to choose your own display.

FURUNO or commercial monitors for BlackBox type display

FSV-84 is a BlackBox type sonar which works with virtually any size multi-sync SXGA (1280 x 1024) LCD. Furuno also offers a premier line of high-quality LCD monitors that are a perfect complement to the FSV-84.



MU-201C

Lineup of FURUNO monitor for BlackBox type.

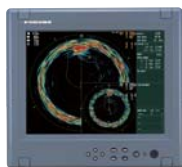

12 inch monitor
MU-120C
Analog RGB x2
DVI x1
Video x3

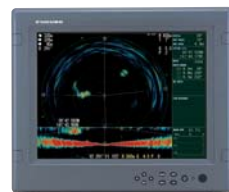

15 inch monitor
MU-155C
Analog RGB x2
DVI x1
Video x3



17 inch monitor
MU-170C
Analog RGB x2
DVI x1
Video x3



21 inch monitor
MU-201C
Analog RGB x1
DVI x1

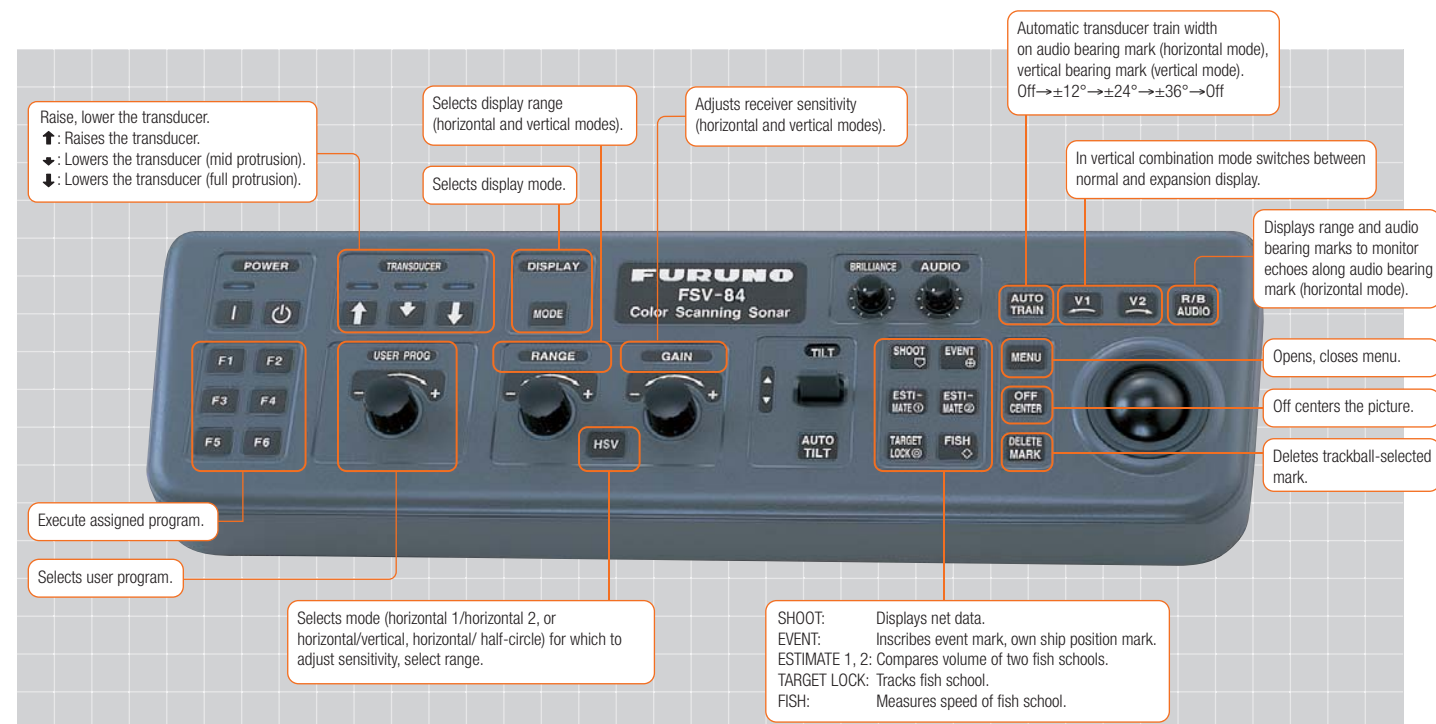

SPECIFICATIONS OF FSV-84

- Display Resolution**
1280(H) x 1024(V) pixels
- Presentation Colors**
Echoes in 32 colors, Marks in 4 colors
- Frequency**
73.5 to 86.5 kHz
- Presentation Modes**
Full-circle scan, Combination of full-circle and Vertical scans, Echo Sounder, Historical presentation and Slant mode
- Orientation**
Head-up, Course-up*, North-up* and True Motion*
*Appropriate sensors required
- Range Scales**
60 - 2,000 m
- Pulse length**
0.5 to 40 ms (depending on range scales)
- Beamwidth (at -3 dB)**
Horizontal Tx Beam width: Horizontal 360° x Vertical 10.7° (-6 dB full width)
Horizontal Rx Beam width: Horizontal 12.6° x Vertical 10.1° (-6 dB full width)
Tilt Angle: -5° to 90°
Vertical Tx Beam width: Horizontal 12.7° x Vertical 118.2° (-6 dB full width)
Vertical Rx Beam width: Horizontal 12.6° x Vertical 12.1° (-6 dB full width)
Vertical Search Range: 0° to 90°
S Tx Beam width: Horizontal 206.7° x Vertical 12.1° (-6 dB full width)
S Rx Beam width: Horizontal 12.6° x Vertical 12.0° (-6 dB full width)
Tilt Angle: -5° to 90°

9. Hull Unit

	FSV-8432	FSV-8442
Travel:	500/800mm	800/1100 mm
Raise/Lower Time:	21 sec	28 sec
Ship Speed:	18 kt	15 kt
(Raise/Lower):	(18kt)	(15kt)

10. Interface

Input (NMEA 0183): CUR, DBS, DBT, DPT, GGA, GLL, GNS, HCC, HCD, HDG, HDM, HDT, MTW, MWV, RMA, RMC, VBW, VDR, VTG, VHW, ZDA, VWT

Input (CIF): System clock, position, speed, bearing, first layer current data, water depth, water temperature, multi-layer current data, net depth, wind

Output: TLL

11. Audio Search
Sector: 30°, 60°, 90°, 180°, 330°
Audio Output: 1.1 W
Frequency: 1 kHz

POWER SUPPLY

BB type (Processor Unit, Control Unit):
100-115/220-230 VAC, 1ø, 50/60 Hz, 2 A

Transceiver unit: 100/110/115/200/230 VAC, 1ø, 50/60 Hz, 15 A

Hull unit: 200-220 VAC, 3ø, 50/60 Hz, 4 A

EQUIPMENT LIST

Standard

- Control Unit: FSV-8401-10
- Processor Unit: FSV-8402-60 (110 VAC) / FSV-8402-70 (220 VAC)
- Transceiver Unit: FSV-841A
- Hull Unit (specify when ordering):
FSV-8432-T (800 mm travel)
FSV-8442-T (1100 mm travel)
- Installation materials and spare parts

Option

- Display Unit: MU-201C
- Control Unit: FSV-8401-10 (for remote display)
- Power Kit for CS-120A: FSV-2403
- Controller Extension Kit: FSV-846 (for control box)
- Attachment Kit: OP10-30
- Installation Material for interface: CP10-04801
- Loudspeaker: SEM-21Q
- E/S Interface: VI-1100A
- Net Sonde Junction Box: CS-170
- 37-core Cable: 10S1258
- Cable Assy.: MJ-A6SPF0012-050C/100 (5/10 m)
- 8-core Cable: 02S8040 (for echo sounder 6m)

INTERCONNECTION DIAGRAM

