

FURUNO

**INSTALLATION MANUAL
GPS NAVIGATOR
GP-150**

1. SYSTEM CONFIGURATIONS	1
2. EQUIPMENT LIST	2
3. DISPLAY UNIT	4
4. ANTENNA UNIT	6
5. WIRING	10
6. INITIAL SETTINGS	12
7. OPTIONAL DGPS	23
PACKING LISTS & INSTALLATION MATERIALS	A-1
OUTLINE DRAWINGS	D-1
INTERCONNECTION DIAGRAM	S-1



FURUNO ELECTRIC CO., LTD.

www.furuno.co.jp



SAFETY INSTRUCTIONS



WARNING



Do not work inside the equipment unless totally familiar with electrical circuits.

Hazardous voltage which can cause electrical shock, burn or serious injury exists inside the equipment.



Turn off the power at the mains switchboard before beginning the installation. Post a sign near the switch to indicate it should not be turned on while the equipment is being installed.

Fire, electrical shock or serious injury can result if the power is left on or is applied while the equipment is being installed.



CAUTION



Ground the display unit to prevent loss of sensitivity and mutual interference.

Confirm that the power supply voltage is compatible with the voltage rating of the equipment.

Connection to the wrong power supply can cause fire or equipment damage. The voltage rating appears on the label at the rear of the display unit.

Use the correct fuse.

Use of a wrong fuse can cause fire or equipment damage.

Keep the following compass safe distances:

	Standard	Steering
Display unit	0.50 m	0.35 m

This page is intentionally left blank.

1. SYSTEM CONFIGURATIONS

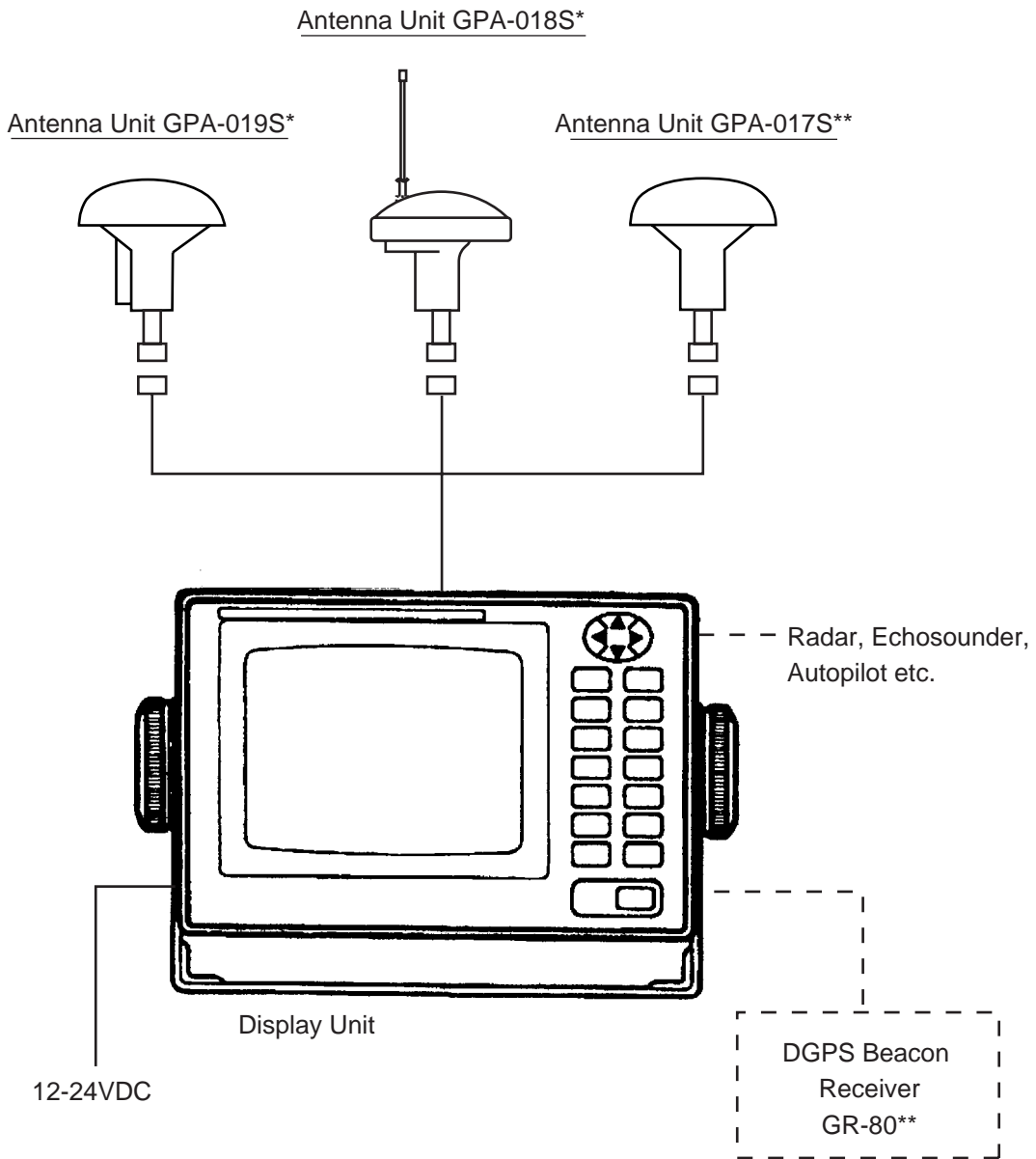

*: w/internal beacon receiver
**: w/o internal beacon receiver

2. EQUIPMENT LISTS

Standards

Name	Type	Q'ty	Remarks		
Antenna Unit	GPA-017S	1	For DGPS		
	GPA-018S				
	GPA-019S				
Display Unit	GP-150-E-N	1	Without Beacon RX		
	GP-150-E-A		With Beacon RX		
Installation Materials	CP20-01900	1 set	See lists at end of manual.	With Antenna Cable	
	CP20-01950			Without Antenna Cable	
Accessories	FP20-01100	1 set			
Spare Parts	SP20-00500	1 set			

Options

Name	Type	Code No.	Remarks
Flush Mount Kit S	OP20-24	004-393-000	For display unit.
Flush Mount Kit F	OP20-25	004-393-280	
Antenna Cable Set	CP20-01700	004-372-110	CP20-01701+30 m cable
	CP20-02700	004-381-160	CP20-02701+30 m cable
	CP20-01710	004-372-120	CP20-01701+50 m cable
	CP20-02710	004-381-170	CP20-02701+50 m cable
Antenna Cable Assy.	TNC-PS-3D-15	000-133-670	15 m
Right Angle Antenna Base	No.13-QA330	000-803-239	For antenna unit.
L-Type Antenna Base	No.13-QA310	000-803-240	
Handrail Antenna Base	No.13-RC5160	000-806-114	
Mast Mount Kit	CP20-01111	004-365-780	
Cable Assy	MJ-A6SPF0011-050C (03S9202)	000-159-690-10	Cross Cable 5m, 6P-4P
	MJ-A6SPF0011-100C (03S9226)	000-159-691-10	Cross Cable 10m, 6P-4P
	MJ-A7SPF0003-050C (20S0241)	000-159-688-11	5m, For DATA4
	MJ-A6SPF0003-050C (20S0093)	000-154-054-10	5m
	MJ-A6SPF0012-050C (64S4073)	000-154-053-10	Cross cable 5m
	MJ-A6SPF0012-100C (64S4071)	000-154-037-10	Cross cable 10m

(Continued from the previous page)

Beacon Receiver Set	OP20-32-1	000-041-018	With GPA-018S
	OP20-32	000-041-019	With whip antenna and OP20-32-1
	OP20-33	000-041-596	With GPS-019S
	OP20-34	000-041-598	Without whip antenna
Rectifier	PR-62	000-013-485	For 100VAC mains
		000-013-486	For 220VAC mains
DGPS Beacon Receiver	GR-80	-	
Whip Antenna	FAW-1.2	000-130-046	1.2 m
Printer	PP-505-FP	000-011-792	
Data Switch Box	MD-200	-	

3. DISPLAY UNIT

The display unit can be installed with either of four methods as shown below. Refer to the outline drawing at the end of manual.

- Locate the unit away from exhaust pipes and vents.
- The mounting location should be well ventilated.
- Mount the unit where shock and vibration are minimal.
- Keep the display unit away electromagnetic field generating equipment such as motor, generator.
- Allow sufficient maintenance space and a sufficient slack in cables for maintenance and repair.

Table Top and Overhead Mounting

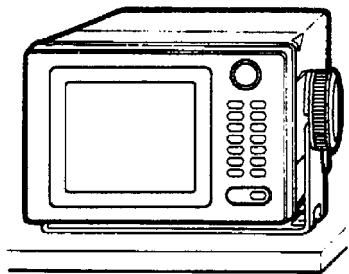
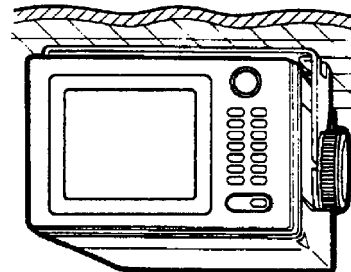

TABLE TOP



OVERHEAD

Display unit mounting methods

Flush mounting type F

An optional flush mount kit type F is required. For details, see outline drawing at end of this manual. (Name: Flush Mount Kit F, Type: OP20-25, Code No.004-393-280)

Name	Type	Code No.	Qty
Self-tapping screw	5X20	000-162-609-10	4
Hex. bolt	M6X12 SUS304	000-162-897-10	2
Spring washer	M6 SUS304	000-158-855-10	2
Cosmetic panel	20-013-1121	100-234-240	1

Flush mounting type S

An optional flush mount kit type S is required. (Name: Flush Mount Kit S, Type: OP20-24, Code No.: 004-393-000)

Name	Type	Code No.	Qty
Wing bolt	M4X30 YBSC2	000-804-799	4
Hex. bolt	M6X12 SUS304	000-162-897-10	2
Wing nut	M4 YBCS2	000-863-306	4
Spring washer	M6 SUS304	000-158-855-10	2
Flush mount metal	20-013-1111	100-234-230	2

1. Prepare a cutout in the mounting location whose dimensions are 242 (W) X 152 (H) mm.
2. Insert the unit to the cutout.
3. Attach two flush mount metals to the unit with two hex bolts (M6X12) and two spring washers.
4. Screw four wing bolts to wing nut.
5. Fasten the unit with wing bolts assembled at step 4, and then tighten nuts.

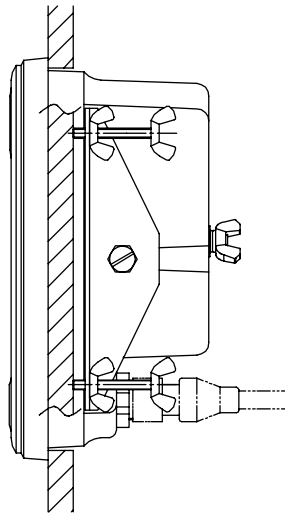

4. ANTENNA UNIT

Mounting

Install the antenna unit referring to the installation diagram at end of manual. When selecting a mounting location for the antenna unit, keep in mind the following points.

- **Select a location out of the radar beam.** The radar beam will obstruct or prevent reception of the GPS satellite signal.
- **Be sure the location offers a clean line-of-sight to satellite.** Objects within line-of-sight to a satellite, for example, a mast or funnel, block reception and cause prolonged acquiring time or interruption of position fix.
- **Mount the unit as high as possible.** Mounting the antenna as high as possible keeps it free of water spray, which can intercept reception of GPS satellite signal, if water spray is frozen.
- **The antenna unit GPA-018S must be grounded.** Connect ground wire of 1.25 sq or larger (local supply) between the antenna unit and a stainless steel screw fastened to the mast.
- **The antenna unit GPA-018S must be taped.** See next page.
- **The antenna unit should be fixed to the mast as below.**



Taping antenna unit GPA-018S

After inserting the whip antenna to the antenna base of GPA-018S, tape the antenna base and whip antenna with self-vulcanizing tape and vinyl tape to reinforce the whip antenna.

1. Wrap the antenna junction point with butyl rubber tape No.15 (NITTO SINKO COOP.) or the equivalent.

How to wrap

- 1) Pull the tape to be about two times in length and wind it up, overlapping by 1/2 the width of the tape.
- 2) Wrap from bottom to top, i.e., from right to left as in the picture below.

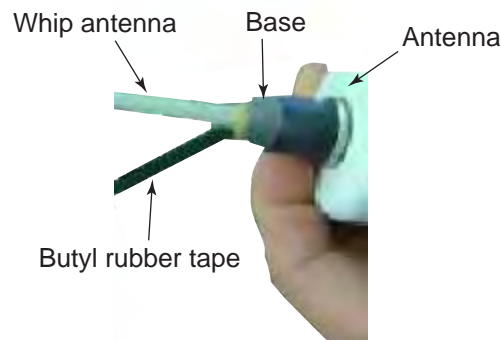

- 3) Wrap the tape from the base to a point about 60 mm, and then back to the base. Keep tension on edge of tape, using finger to hold tape. Then, squeeze edges of tape with thumb and index finger.

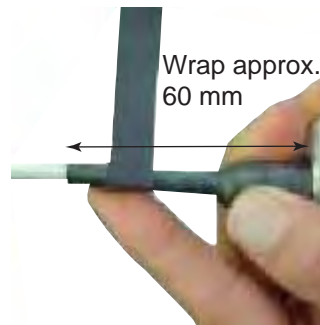

2. Completely cover the butyl rubber tape with white vinyl tape, wrapping from the base to the last wind of butyl rubber tape and then back to the base.

How to wrap

- 1) Being careful not to pull the tape too tightly, wind tape, overlapping by approx. 1/3 of tape width.
- 2) Squeeze edges of tape with thumb and index finger.



Extending Antenna Cable Length

The standard cable is 15m long. 30m and 50m long extension cable sets are optionally available.

◆ Extension cable line-up

Fabricate the end of antenna cable and attach the coaxial connector. Details are shown on next page.

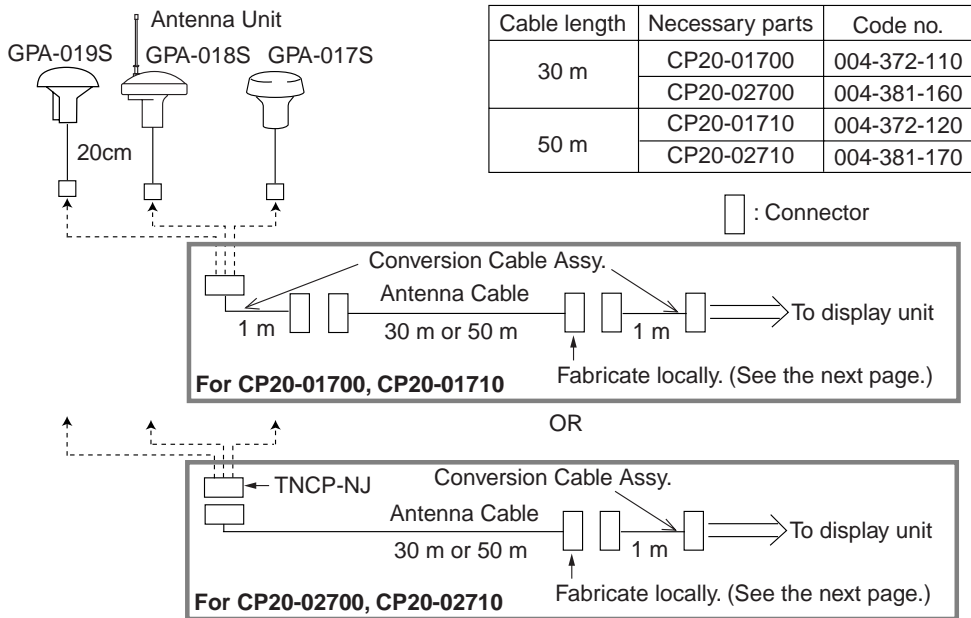

Extension Cable Line-up

◆ Waterproofing the connector

Wrap connector with vulcanizing tape and then vinyl tape. Bind the tape end with cable-tie.



How to waterproof the connector of the antenna cable

How to attach the N-P-8DFB connector

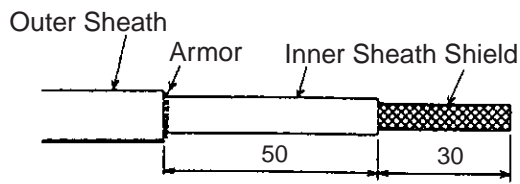

Remove outer sheath and armor by the dimensions shown left.
Expose inner sheath and shield by the dimensions shown left.

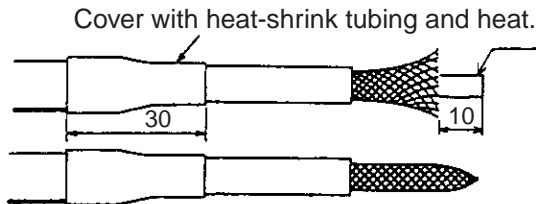

Cut off insulator and core by 10mm.

Twist shield end.

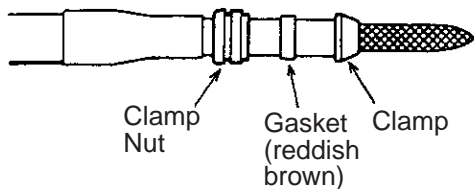

Clip on clamp nut, gasket and clamp as shown left.

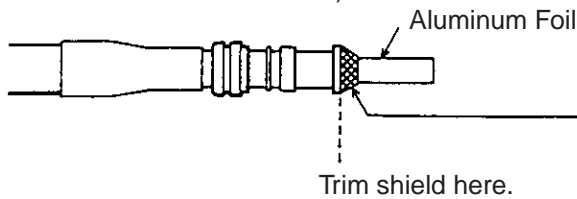

Fold back shield over clamp and trim.



Cut aluminum foil at four places, 90° from one another.

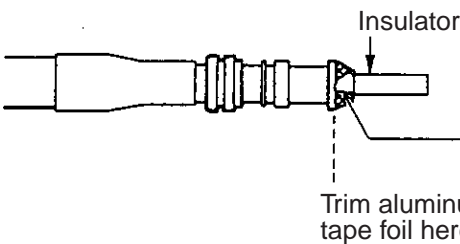

Fold back aluminum foil onto shield and trim.

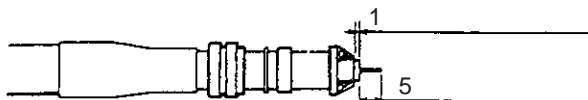

Expose the insulator by 1mm.

Expose the core by 5mm.

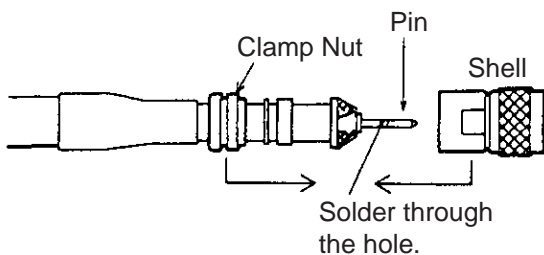



Slip the pin onto the conductor. Solder them together through the hole on the pin.

Insert the pin into the shell. Screw the clamp nut into the shell.
(Tighten by turning the clamp nut. Do not tighten by turning the shell.)

5. WIRING

The figure below shows the connection of cables on rear of display unit.

 CAUTION
 Ground the display unit to prevent loss of sensitivity and mutual interference.

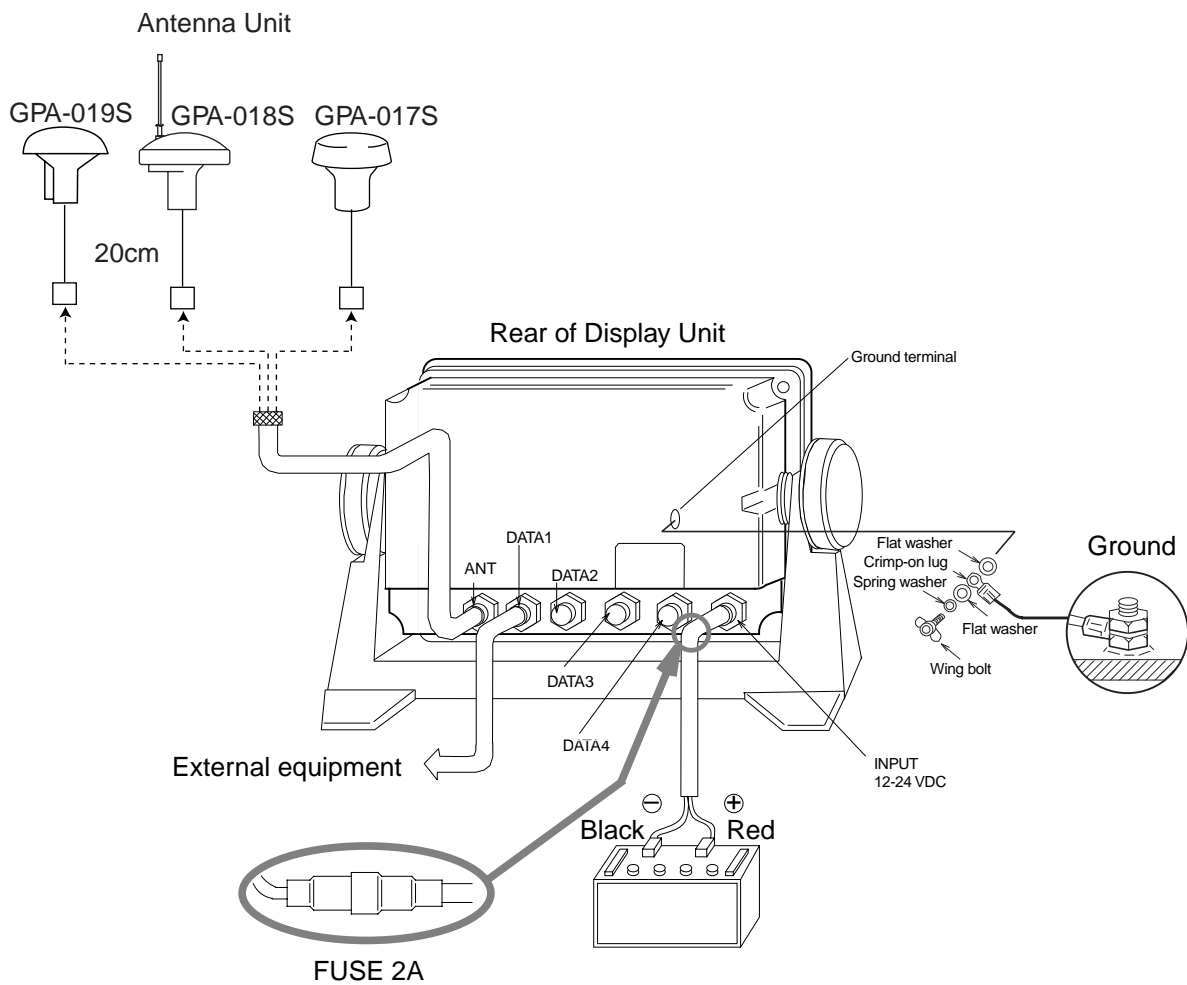

Connection of cables on display unit

Grounding

The display unit contains several CPUs. While they are operating, they radiate noise, which can interfere with other radio equipment. Ground the unit as follows to prevent it.

- The grounding wire should be 1.25sq or larger.
- The grounding wire should be as short as possible.

External Equipment

The DATA1, DATA2, and DATA3 ports are used to connect an external equipment such as autopilot, remote display, navigation equipment. Refer to the interconnection diagram on page S-1 for connection of DATA1, DATA2 and DATA 3 port. The DATA4 port is used to connect NMEA equipment, PC or DGPS beacon receiver as follows;

Connection of DATA4 port

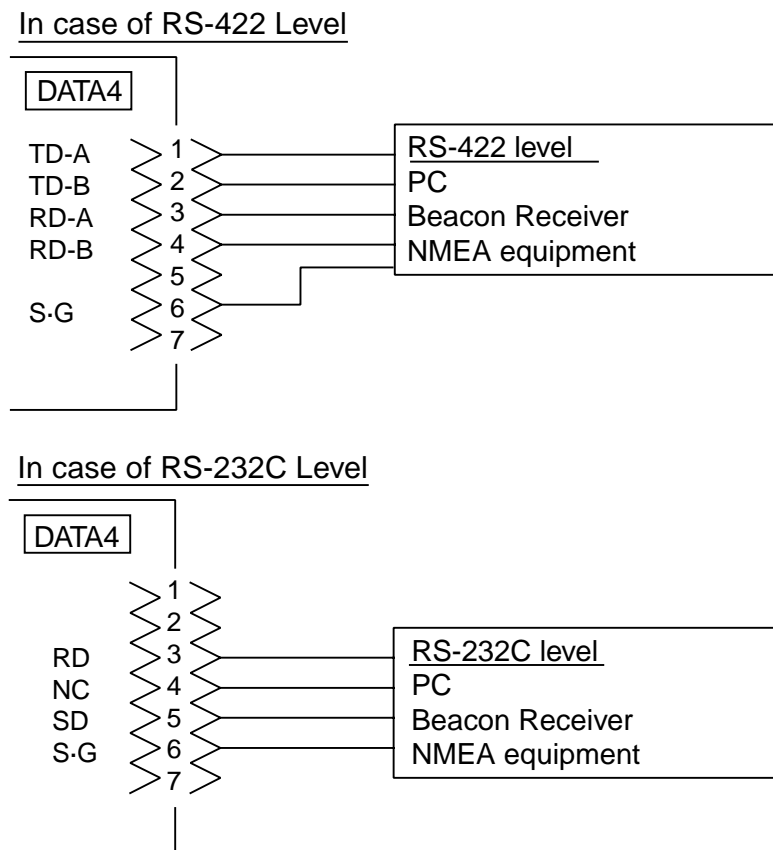

NOTE: The selection of input/output signal level is done by menu operation. See page 19.

6. INITIAL SETTINGS

Checking Operation

1. Turn on the GP-150.
2. Confirm that "OK" and "BEACON RCVR INSTALLED" are displayed on the self-test display.

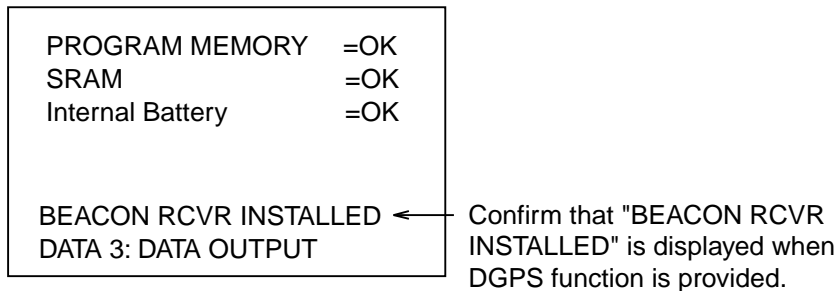

Self-test display at equipment start up

3. Press **MENU ESC, 8** and **1**. Confirm that "OK" are displayed for PROGRAM MEMORY, SRAM, Internal Battery, GPS and BEACON.

DGPS Setup

The default setting is "manual".

Automatic DGPS setup

GP-150 can automatically select optimum reference station. If it takes more than five (5) minutes to fix DGPS position at the automatic mode, switch to manual mode. Use the manual mode when an external beacon receiver has no automatic function of station selection.

1. Press **MENU ESC, 9** and **7** to display the WAAS/DGPS SETUP menu.

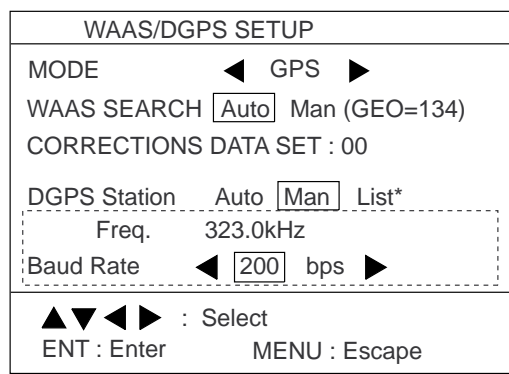

[] : These items appear when "Man" is selected.
 * : Only when the internal beacon receiver is equipped.

DGPS SETUP menu

2. Press ▲ or ▼ to select MODE and press ◀ to select INT BEACON.
3. Press ▲ or ▼ to select DGPS Station.

4. Press ◀ to select Auto.
5. Press the **NU/CU ENT** key.
6. Press the **MENU ESC** key.

Manual DGPS setup

Enter frequency and baud rate of station.

1. Press **MENU ESC**, **9** and **7** to display the WAAS/DGPS SETUP menu.
2. Press ▲ or ▼ to select MODE and press ◀ to select INT BEACON.
3. Press ▲ or ▼ to select Ref. Station.
4. Press ▶ to select Man.
5. Press ▼ to select Freq.
6. Enter frequency in four digits (283.5 kHz to 325.0 kHz).
7. Press the **NU/CU ENT** key. "Baud Rate" appears in reverse video.
8. Press ◀ or ▶ to select baud rate; 25, 50, 100 or 200 bps.
9. Press the **MENU ESC** key.

Nearest DGPS station list

The STATION NEAREST LIST shows the five closest DGPS beacon stations, including user-programmed stations. For user-programmed stations, see Operator's Manual.

1. Press **MENU ESC**, **9** and **7** to display the WAAS/DGPS SETUP menu.
2. Press ▲ or ▼ to select MODE and press ◀ to select INT BEACON.
3. Press ▲ or ▼ to select Ref. Station.
4. Press ▶ to select List.

After the message "PLEASE WAIT" appears, the following list is shown. Asterisked stations mean user-programmed stations.

STATION NEAREST		
USER Setup	No	Yes
Freq.	RNG	BRG
1 320.5kHz	0.6nm	202°*
2 320.5kHz	22.3nm	244°
3 316.0kHz	70.3nm	348°
4 320.0kHz	87.2nm	77°
5 288.0kHz	93.7nm	110°

▲▼◀▶ : Select
ENT : Enter MENU : Escape

*: User-programmed station

5. Press ▲ or ▼ to select the station desired.
6. Press the **ENTER** key.
7. Press the **MENU ESC** key.

DGPS Operation checking

1. Press **MENU ESC** and **7**.
2. Press  several times to display the following.

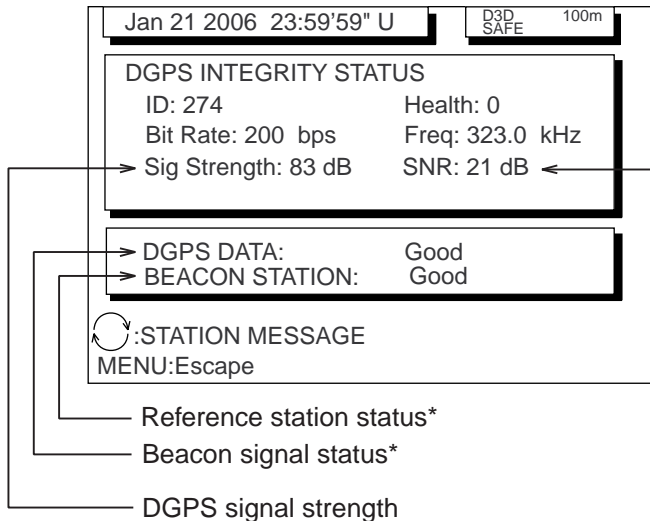

DGPS signal strength
 This value is between 1 and 84.
 The higher the value, the stronger the signal.
 If a noise appears at reception bandwidth,
 the value becomes bigger.

Signal to noise ratio

This value is between 1 to 22. The higher the value, the better the reception of beacon signal. When this value is less than 20, the error is included in the correction data. In this time, position fixing is done by using past position data. When the ship is in the service area of a beacon station, this value should be 21 or 22. If not, check as follows.

- Check the grounding.
- Check the radar beam interference.
- Check the noise of power generator of the ship.

*It is necessary that GPS is working properly.
 When GPS is malfunctioning though DGPS is normal,
 the message "No Good" may be shown.

Input/Output Setting

The GP-150 can output navigation information to external equipment. For example, it can output position data to a radar or echo sounder for display on their display screen. You can convert a Loran Plotter to a GPS Plotter with position data from the GP-150.

Before selecting data to output, confirm what data the external equipment requires. Output necessary data only. Outputting unnecessary data can cause receiving problems at the external equipment.

Talker

All data transmitted by marine electronics equipment is prefixed with a two-character code which tells external equipment what equipment is transmitting data. This two-character code is called the talker. The GP-150 contains the talkers GP, LC and DE.

Because GPS is a relatively new system some early model equipments do not recognize the GP talker name. In this case transmit data using a conventional talker, which equipment recognizes, such as Loran C.

Data format and data output availability

Output data sentence of IEC 61162-1 and NMEA 0183 Ver. 1.5/2.0.

- AAM: Waypoint arrival alarm
- APB: Autopilot sentence B
 magnitude of cross track error, direction to steer, arrival alarm, bearing to waypoint
 ("Heading to steer to destination waypoint data" not used)
- BOD: Bearing-origin to destination
- BWC: Bearing and distance to waypoint-great circle
- BWR: Bearing and distance to waypoint-rhumb line
- BWW: Bearing-waypoint to waypoint
- DTM: Datum reference
- GGA: Global positioning system (GPS) fix data
 time of fix, latitude, longitude, quality indicator, number of satellites in use, DOP,
 altitude, geoidal separation
 ("age of dgps data" and "differential reference station ID" not used)
- GLL: Geographic position-latitude/longitude
- GNS: GNSS fix data
- GBS: GPS satellite fault detection
- RMB: Recommended minimum navigation information cross track error, direction to steer,
 origin and destination waypoint ID, destination waypoint latitude and longitude,
 range and bearing of destination waypoint, destination closing velocity, arrival
 alarm
- RMC: Recommended minimum specific GPS/TRANSIT data
 UTC of position fix, latitude and longitude, ground speed and course, date,
 magnetic variation
- RTE: Routes
- VDR: Set and drift
- VTG: Course over ground and ground speed
- WCV: Waypoint closure velocity
- WPL: Waypoint location
- XTE: Cross-track error, measured
- ZDA: Time and date
- Rnn: Routes

Also, following NMEA 0183 Ver. 1.5 sentence is output.

- APA: Autopilot sentence "A"
 magnitude of cross track error, direction to steer, arrival alarm, bearing origin to
 destination.

Note: BWC, BWR, GGA, GLL, RMB, RMC or WPL is required to output DTM.

6. INITIAL SETTINGS

Input data sentence of NMEA 0183 Ver. 1.5/2.0

Checksum is checked if attached, and if any errors are found, the sentence becomes invalid.

Talker ID is not distinguished.

DBT: Depth below transducer

DPT: Depth

HDG: Heading, deviation and variation

HDM: Heading, magnetic

HDT: Heading, true

MTW: Water temperature

TLL: Target latitude and longitude

VBW: Dual ground/water speed

VHW: Water speed and heading.

FURUNO proprietary sentence

AGFPA: Autopilot information from FURUNO autopilot equipments.

AGFPA: Autopilot information from FURUNO autopilot equipments

Port	Input	Output
DATA1 DATA2	<u>NMEA 0183</u> <u>Ver. 1.5 /2.0</u> AGFPA , DBT, DPT, HDG, HDM, HDT, MTW, TLL, VBW, VHW	<u>IEC 61162-1/NMEA 0183 Ver.1.5/</u> <u>Ver.2.0</u> AAM, APA, APB, BOD, BWC, BWR, BWW, GGA, GLL, GNS, RMB, RMC, VDR, VTG, WCV, WPL, XTE, ZDA, GBS, Rnn, RTE, DTM
DATA3	External MOB	LOG PULSE Same as the data output form "DATA1"
DATA4	DGPS or general data (Selected by menu)	General data <u>IEC 61162-1/NMEA 0183 Ver.1.5/</u> <u>Ver.2.0</u> AAM, APA, APB, BOD, BWC, BWR, BWW, GGA, GLL, GNS, RMB, RMC, VDR, VTG, WCV, WPL, XTE, ZDA, GBS, Rnn, RTE

Note: BWC, BWR, GGA, GLL, RMB, RMC or WPL is required to output DTM.

General data

- 1) Input of waypoint data
Connect YEOMAN equipment to DATA4 port.
- 2) Input and output of waypoint / route data

TX Rate of operation

The TX rate of operation is the percentage of data output in one second, and it appears on the screen. Refer to page 18. If short intervals are assigned to many sentences, the rate of operation increases as illustrated below

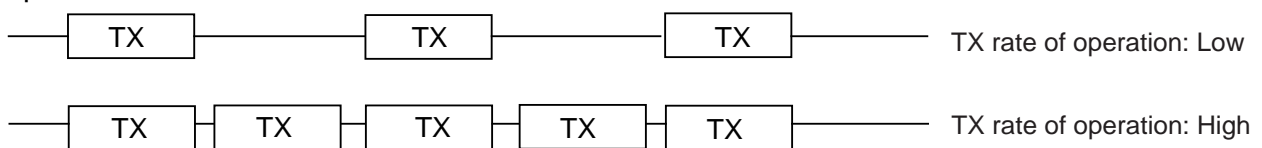

Note 1: When outputting data without rest intervals between data, TX rate of operation is 100%. In this case, wrong data may be shown on the receiver because it cannot recognize intervals between data. Thus, do not output unnecessary data or set TX interval to large value so that TX rate of operation becomes small.

Note 2: When the external equipment cannot display correct data input from the GP-150, the rate of operation should be lowered. For example, set a rate of operation less than 60 % for the Temperature Indicator TI-20.

DATA 1 output setting

1) Press **MENU ESC, 9** and **3**. The DATA 1, 3 OUTPUT SETUP menu appears.

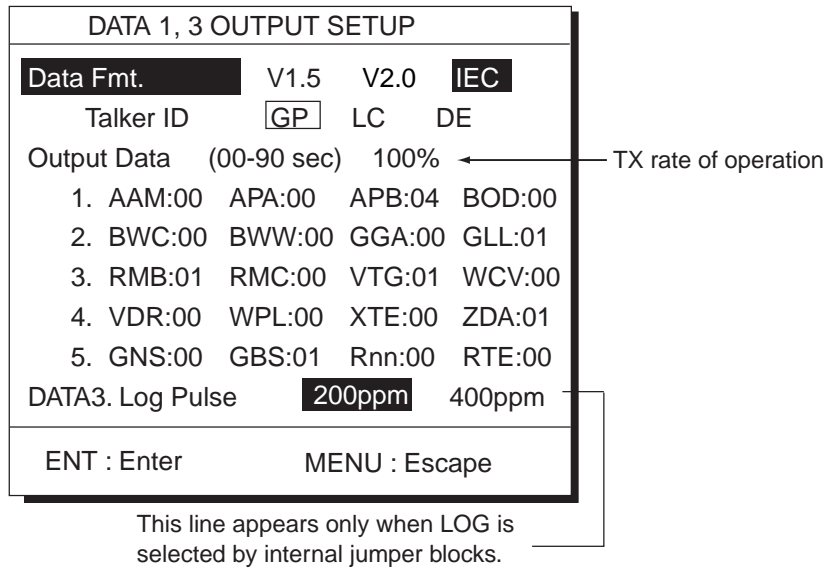

Settings shown above are default settings.

DATA 1, 3 OUTPUT SETUP menu

- 2) Press **▲** or **▼** to select Data Fmt.
- 3) Press **◀** or **▶** to select V1.5, V2.0 or IEC.
- 4) Press the **NU/CU ENT** key. Talker ID appears in reverse video.
- 5) Press **◀** or **▶** to select GP, LC or DE.
- 6) Press the **NU/CU ENT** key.
- 7) Enter Tx interval for each output data sentence in line 1. Tx interval is available in 00, 01, 02, 03, 04, 05, 06, 10, 15, 20, 30, 60, and 90 sec.
- 8) Press the **NU/CU ENT** key.
- 9) Enter Tx interval for each output data sentence in lines 2 through 5. Press the **NU/CU ENT** key after setting each line.

In great circle navigation, BWC and WNC are output but BWR and WNR are not. In rhumb line navigation, BWR and WNR are output but BWC and WNC are not. The total data output are shown by percentage on the third line.

DATA 2 output setting

1) Press **NU/CU MENU, 9** and **4**. The DATA 2 OUTPUT SETUP menu appears.

DATA2 OUTPUT SETUP			
Data Fmt.	V1.5	V2.0	IEC
Talker ID	GP	LC	DE
Output Data	(00-90 sec)	100%	
1.	AAM:00	APA:00	APB:04 BOD:00
2.	BWR:00	BWW:00	GGA:00 GLL:01
3.	RMB:01	RMC:00	VTG:01 WCV:00
4.	VDR:00	WPL:00	XTE:00 ZDA:01
5.	GNS:00	GBS:01	Rnn:00 RTE:00
▲▼◀▶ : Select ENT : Enter MENU : Escape			

Setting shown here are default settings.

DATA 2 OUTPUT SETUP menu

2) Follow the procedure for setting DATA 1 output.

DATA 3 output setting

The DATA 3 can output NMEA 0183 (V1.5/V2.0) /IEC 61162-1 data or log pulse by selecting inner jumper blocks. For NMEA 0183 (V1.5/V2.0) /IEC 61162-1, the same signal of DATA 1 is output from DATA 3.

Selection of NMEA0183 or log pulse

Output data NP board	NMEA 0183 (V1.5/ V2.0)/IEC 61162-1 (default setting)	Log pulse
JP3	#1-2	#2-3
JP4	#1-2	#2-3
JP10	#1-2	#2-3

Rate of log pulse output

150 mA Max.
50 VDC

Procedure for setting of log pulse rate

- 1) Press **MENU ESC, 9** and **3**.
- 2) Press **▲** or **▼** to select "DATA 3. Log Pulse".
- 3) Press **◀** or **▶** to select log pulse for external equipment; 200 ppm or 400 ppm.
- 4) Press the **NU/CU ENT** key.
- 5) Press the **MENU ESC** key.

Setting DATA 4 to Data Output

1) Press **MENU ESC**, **9** and **5**. The DATA 4 I/O SETUP menu appears.

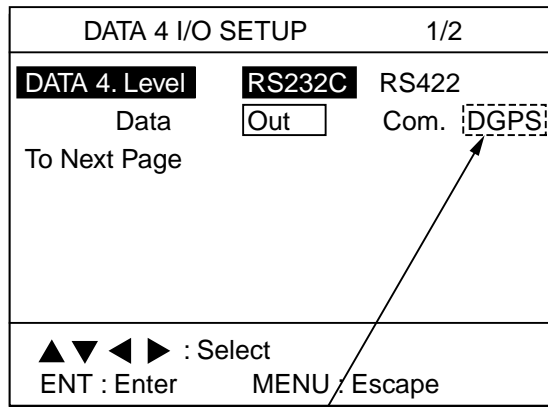

Appears only when external DGPS receiver is used.

DATA 4 I/O SETUP menu

- 2) Press ▲ or ▼ to select DATA4. Level.
- 3) Press ◀ or ▶ to select level of external equipment; RS232C or RS422.
- 4) Press the **NU/CU ENT** key.
- 5) Press ◀ or ▶ to select Out.
- 6) Press ▼ to select to Next Page. The DATA 4 I/O SETUP <out> menu appears.

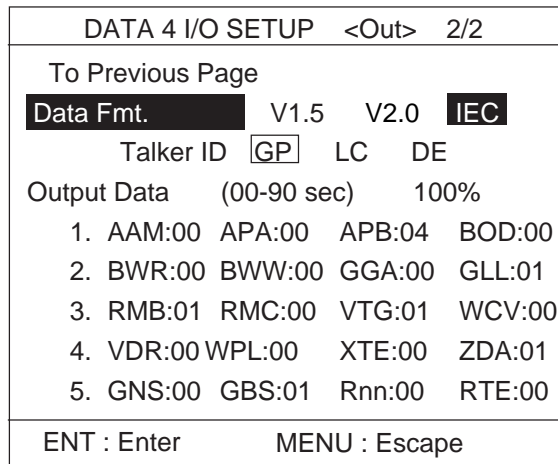

DATA 4 I/O SETUP <out> menu

7) Follow "DATA 1 output setting" from step 2.

Setting DATA 4 to “COM.” (general data)

Waypoints and Routes data can be received from a personal computer, through the DATA 4 port.

- 1) Press **MENU ESC, 9** and **5**.
- 2) Press **▲** or **▼** to select DATA4. Level.
- 3) Press **◀** or **▶** to select level of personal computer; RS232C or RS422.
- 4) Press the **NU/CU ENT** key.
- 5) Press **▶** to select Com.
- 6) Press **▼** to select To Next Page. The DATA 4 I/O SETUP <Com.> menu appears.

DATA 4 I/O SETUP <Com.> 2/2		
To Previous Page		
Baud Rate	◀ 9600 bps ▶	
Load Data	WPT/RTE	WPT
Command	Stop	Start
Save Data	WPT/RTE	
Command	Stop	Start
▲▼◀▶ : Select ENT : Enter MENU : Escape		

DATA 4 I/O SETUP <Com.> menu

- 7) Press **▲** or **▼** to select Baud Rate.
- 8) Press **◀** or **▶** to select baud rate; 4800bps, 9600bps or 19200bps.
- 9) Press the **NU/CU ENT** key.
- 10) Press **◀** or **▶** to select WPT/RTE.
- 11) Press **▼** to select Command. Stop, on the same line as Command, appears in reverse video.
- 12) Press **▶** to select Start. The message shown in figure below appears.

Loading erases current data and stops Route navigation Are you sure to load? ENT: Yes MENU: No
--

- 13) Press the **NU/CU ENT** key. The message shown in below appears while data is being loaded.

Now loading Waypoint/Route data ! MENU: Stop
--

6. INITIAL SETTINGS

- 14) Output data from the computer. When loading data is completed, the cursor shifts to Stop.
- 15) Press the **MENU ESC** key.

Setting DATA 4 to DGPS

An external DGPS receiver can be connected to the DATA 4 port.

Follow the procedure below to setup the GP-150 according to the specifications of the DGPS receiver.

- 1) Press **MENU ESC, 9** and **5**.
- 2) Press **▲** or **▼** to select Level.
- 3) Press **◀** or **▶** to select level; RS232C or RS422.
- 4) Press the **NU/CU ENT** key.
- 5) Press **◀** or **▶** to select DGPS.
- 6) Press **▼** to select To Next Page.

DATA 4 I/O SETUP <DGPS> 2/2			
To previous Page			
First Bit	MSB	LSB	
Parity	<input type="text" value="EVEN"/>	ODD	NONE
Stop Bit	<input type="text" value="1"/>	2	
Baud Rate	<input type="text" value="4800"/>	9600	
▲▼◀▶ : Select			
ENT: Enter MENU: Escape			

DATA 4 I/O SETUP <DGPS> menu

- 7) Press **▲** or **▼** to select First Bit.
- 8) Press **◀** or **▶** select first bit; MSB or LSB.
- 9) Press **▼** to select Parity.
- 10) Press **◀** or **▶** to select parity bit; EVEN, ODD or NONE.
- 11) Press **▼** to select Stop Bit.
- 12) Press **◀** or **▶** to select stop bit; 1 or 2.
- 13) Press **▼** to select Baud Rate.
- 14) Press **◀** or **▶** to select baud rate; 4800 or 9600.
- 15) Press the **NU/CU ENT** key.
- 16) Press the **MENU ESC** key.

7. OPTIONAL DGPS

Beacon Receiver Set GR-80

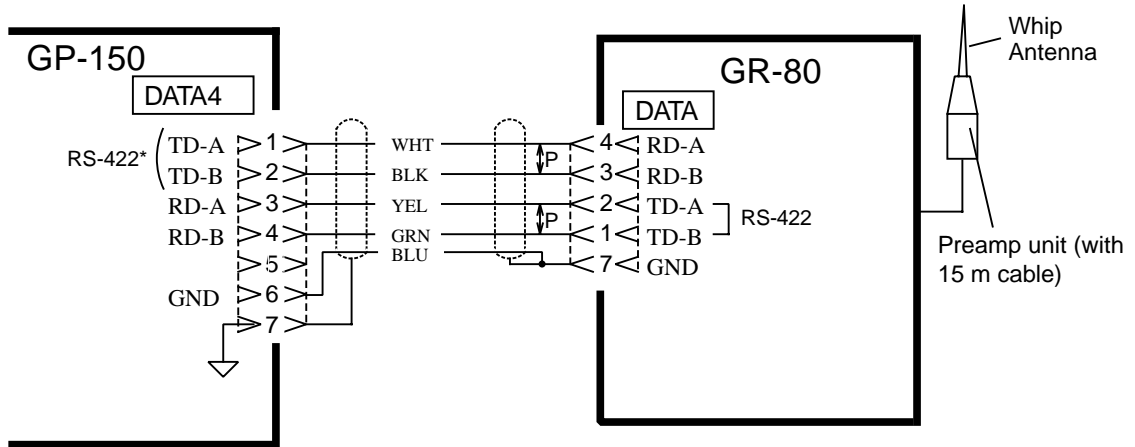

* This connection is required for L/L Auto mode of GR-80.

When the GP-150 is connected with Beacon Receiver GR-80, do the setting as follows.

Signal level	RS-422 *1
First Bit	LSB
Parity	NONE
Stop Bit	1
Baud Rate	4800 or 9600 *1

*1: Coincide with the setting of the Beacon Receiver GR-80.

Refer to page 22 for DGPS setup.

PACKING LIST GP-150- *- *0-15-*

20AZ-X-9853 -3

1/1

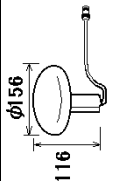
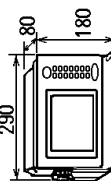
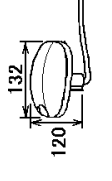
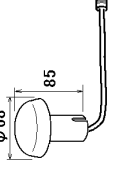
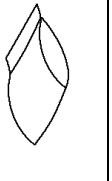
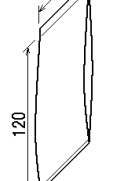
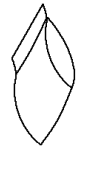

NAME	OUTLINE	DESCRIPTION/CODE	Q'TY
ユニット			
空中線部		GPA-019S	1
ANTENNA UNIT		000-142-545-01 **	(*1)
受信演算部		GP-150-*	1
DISPLAY UNIT		000-042-077-00 **	
空中線部		GPA-018S	1
ANTENNA UNIT		000-041-895-00 **	(*1)
空中線部		GPA-017S	1
ANTENNA UNIT		000-040-537-00 **	(*1)
予備品			
予備品		SP20-00500	1
SPARE PARTS		000-040-717-00	
付属品			
フィルターナー		02-155-1082-1	1
FILTER CLEANER		100-332-651-10	
工事材料			
操作・表示部工事材料		CP20-01101	1
INSTALLATION MATERIALS		004-369-790-00	

コード番号末尾の[*]*は、選択品の代表コードを表します。
CODE NUMBER ENDING WITH "****" INDICATES THE CODE NUMBER OF REPRESENTATIVE MATERIAL.



2.(*1)の空中線部は仕様により決定されます。

ANTENNA UNIT HAS BEEN DETERMINED BY SPECIFICATION.

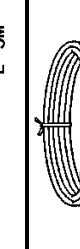
(略図の寸法は、参考値です。DIMENSIONS IN DRAWING FOR REFERENCE ONLY.)

NAME	OUTLINE	DESCRIPTION/CODE	Q'TY
ケーブル組品MJ		MJ-A2SPF0014-030C	1
POWER CABLE		000-158-000-10	
ケーブル組品MJ		MJ-A6SPF0003-050C	1
SIGNAL CABLE ASSEMBLY		000-154-054-10	
ケーブル組品		TNC-PS/PS-3D-L15M-R	1
CABLE ASSY.		000-133-670-11	

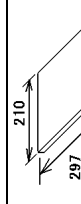
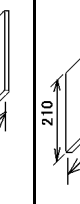
図書 DOCUMENT

操作要領書		OS*-44400-*	1
OPERATOR'S GUIDE		000-158-017-1 **	
装備要領書		IM*-44400-*	1
INSTALLATION MANUAL		000-158-015-1 **	
取扱説明書		OM*-44400-*	1
OPERATOR'S MANUAL		000-158-013-1 **	

A-1





型式/コード番号が2段の場合、下段より上段に代わる過渡期品であり、どちらが入っています。なお、品質は変わりません。

TWO TYPES AND CODES MAY BE LISTED FOR AN ITEM. THE LOWER PRODUCT MAY BE SHIPPED IN PLACE OF THE UPPER PRODUCT. QUALITY IS THE SAME.
20AZ-X-9853

PACKING LIST GP-150- *- *0-N-*

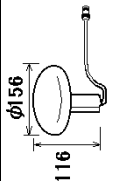
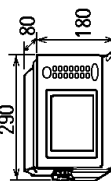
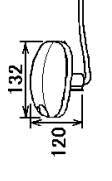
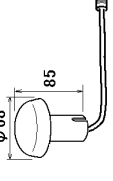
20AZ-X-9854 -2

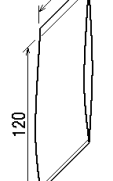

1/1

NAME	OUTLINE	DESCRIPTION/CODE	Q'TY
ユニット			
空中線部		GPA-019S	1
ANTENNA UNIT		000-142-545-01 **	(*1)
受信演算部		GP-150-*	1
DISPLAY UNIT		000-042-077-00 **	
空中線部		GPA-018S	1
ANTENNA UNIT		000-041-895-00 **	(*1)
空中線部		GPA-017S	1
ANTENNA UNIT		000-040-537-00 **	(*1)
予備品			
予備品		SP20-00500	1
SPARE PARTS		000-040-717-00	
付属品			
フィルターナー		02-155-1082-1	1
FILTER CLEANER		100-332-651-10	
工事材料			
操作・表示部工事材料		CP20-01101	1
INSTALLATION MATERIALS		004-369-790-00	

1.コード番号末尾の[*]は、選択品の代表コードを表します。
CODE NUMBER ENDING WITH "*" INDICATES THE CODE NUMBER OF REPRESENTATIVE MATERIAL.

2.(*1)の空中線部は仕様により決定されます。
ANTENNA UNIT HAS BEEN DETERMINED BY SPECIFICATION.

(略図の寸法は、参考値です。DIMENSIONS IN DRAWING FOR REFERENCE ONLY.)

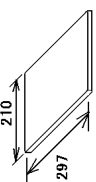
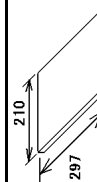
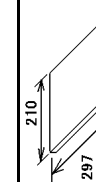
NAME	OUTLINE	DESCRIPTION/CODE	Q'TY
ケーブル組品MJ		MJ-A2SPF0014-030C	1
POWER CABLE		000-158-000-10	
ケーブル組品MJ		MJ-A6SPF0003-050C	1
SIGNAL CABLE ASSEMBLY		000-154-054-10	
図書			
操作要領書		OS*-44400-*	1
OPERATOR'S GUIDE		000-158-017-1*	**
装備要領書		IM*-44400-*	1
INSTALLATION MANUAL		000-158-015-1*	**
取扱説明書		OM*-44400-*	1
OPERATOR'S MANUAL		000-158-013-1*	**

型式/コード番号が2段の場合、下段より上段に代わる過渡期品であり、どちらが入っています。なお、品質は変わりません。

TWO TYPES AND CODES MAY BE LISTED FOR AN ITEM. THE LOWER PRODUCT MAY BE SHIPPED IN PLACE OF THE UPPER PRODUCT. QUALITY IS THE SAME.

A-2

20AZ-X-9854

FURUNO

CODE NO.	004-369-790-00	20AX-X-9404 -1
TYPE	CP20-01101	1/1

工事材料表 INSTALLATION MATERIALS					
番号 NO.	名称 NAME	略図 OUTLINE	型名/規格 DESCRIPTIONS	数量 Q'TY	用途/備考 REMARKS
1	+トラスタップ [®] ソネジ [®] 1ｼｬ SELF-TAPPING SCREW		5X20 SUS304 CODE NO. 000-162-608-10	4	

型式/コード番号が2段の場合、下段より上段に代わる過渡期品であり、どちらかが入っています。なお、品質は変わりません。

TWO TYPES AND CODES MAY BE LISTED FOR AN ITEM. THE LOWER PRODUCT MAY BE SHIPPED IN PLACE OF THE UPPER PRODUCT. QUALITY IS THE SAME.

(略図の寸法は、参考値です。 DIMENSIONS IN DRAWING FOR REFERENCE ONLY.)

FURUNO

CODE NO.	000-040-717-00	20A1-X-9301 -2 1/1
TYPE	SP20-00500	BOX NO. P

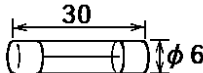
SHIP NO.	SPARE PARTS LIST FOR		U S E			SETS PER VESSEL	
ITEM NO.	NAME OF PART	OUTLINE	DWG. NO. OR TYPE NO.	QUANTITY			REMARKS/CODE NO.
				WORKING		SPARE	
				PER SET	PER VES		
1	ヒューズ FUSE		FGB0-A 125V 2A PBF ----- FGB0-A 2A AC125V	1		3	000-155-849-10 ----- 000-549-062-00
MFR'S NAME	FURUNO ELECTRIC CO.,LTD.		DWG NO.	20A1-X-9301		1/1	

(略図の寸法は、参考値です。 DIMENSIONS IN DRAWING FOR REFERENCE ONLY.)

型式/コード番号が2段の場合、下段より上段に代わる過渡期品であり、どちらかが入っています。 なお、品質は変わりません。

TWO TYPES AND CODES MAY BE LISTED FOR AN ITEM. THE LOWER PRODUCT MAY BE SHIPPED IN PLACE OF THE UPPER PRODUCT. QUALITY IS THE SAME.

Antenna Cable Set
 CP20-01700 (004-372-110)
 CP20-01710 (004-372-120)

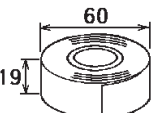
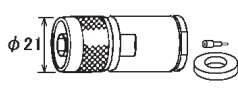
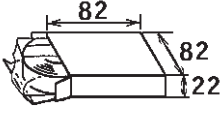

FURUNO

CODE NO.	004-372-420-00	20AG-X-9405 -4
TYPE	CP20-01701	1/1

工事材料表 INSTALLATION MATERIALS					
番号 NO.	名称 NAME	略図 OUTLINE	型名/規格 DESCRIPTIONS	数量 Q'TY	用途/備考 REMARKS
1	変換ケーブル組品 CONVERT CABLE ASSY.		NJ-TP-3DXV-1 CODE NO. 000-123-809-00	2	
2	ビニルテープ VINYL TAPE		N0360 0.2X19X10000 CODE NO. 000-835-215-00	1	
3	コネクタ(N) CONNECTOR		N-P-8DFB-CF CODE NO. 000-156-918-10	1	
4	絶縁テープ SELF-BONDING TAPE		Uテープ 0.5X19X5M Uテープ 0.5X19X5M CODE NO. 000-165-833-10 000-800-985-00	1	

FURUNO

CODE NO.		20AG-X-9404 -2
TYPE		1/1

工事材料表 INSTALLATION MATERIALS					
番号 NO.	名称 NAME	略図 OUTLINE	型名/規格 DESCRIPTIONS	数量 Q'TY	用途/備考 REMARKS
1	アンテナケーブル組品 ANTENNA CABLE ASSY.		8D-FB-CV *30M* CODE NO. 000-111-547-00	1	選択 TO BE SELECTED
2	アンテナケーブル組品 CABLE ASSY.		8D-FB-CV *50M* CODE NO. 000-117-599-00	1	選択 TO BE SELECTED



Antenna Cable Set

CP20-02700 (004-381-160)

CP20-02710 (004-381-170)

FURUNO

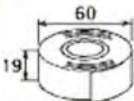
CODE NO.	004-381-190-00	20AX-X-9401 -6
TYPE	CP20-02701	1/1

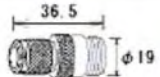
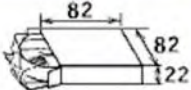
工事材料表 INSTALLATION MATERIALS					
番号 NO.	名称 NAME	略図 OUTLINE	型名/規格 DESCRIPTIONS	数量 Q'TY	用途/備考 REMARKS
1	ビニールテープ N0360 VINYL TAPE		0.2X19X10000 粘着テープ CODE NO. 000-835-215-00	1	
2	変換ケーブル組品 CONVERT CABLE ASSY.		NJ-TP-30XV-1 CODE NO. 000-123-809-00	1	
3	コネクタ (N) CONNECTOR		N-P-8DFB-CF CODE NO. 000-156-918-10	1	
4	コネクタ (TNC-N) CONNECTOR		TNCP-NJ CODE NO. 000-156-599-10	1	
5	絶縁テープ SELF-BONDING TAPE		Uテープ 0.5X19X5M Uテープ 0.5X19X5M CODE NO. 000-165-833-10 000-800-985-00	1	

FURUNO

CODE NO.		20AG-X-9404 -2
TYPE		1/1



工事材料表 INSTALLATION MATERIALS		GP-80, GP-90, SC-55, GP-3500/F, GP-1850, GP-1650, FA-100, FA-150, GP-1640/F, SC-60/120, GD/GP-280/680/380			
番号 NO.	名称 NAME	略図 OUTLINE	型名/規格 DESCRIPTIONS	数量 Q'TY	用途/備考 REMARKS
1	アンテナケーブル組品 ANTENNA CABLE ASSY.		8D-FB-CV *30M* CODE NO. 000-111-547	1	選択 TO BE SELECTED
2	アンテナケーブル組品 CABLE ASSY.		8D-FB-CV *50M* CODE NO. 000-117-599	1	選択 TO BE SELECTED

表 1 TABLE 1

寸法区分 (mm) DIMENSIONS	公差 (mm) TOLERANCE
L ≤ 50	± 1.5
50 < L ≤ 100	± 2.5
100 < L ≤ 500	± 3

表 2 TABLE 2

仕様 MODEL	質量 (kg±10%) MASS
ビーコン有り W/ BEACON	2.4
ビーコン無し W/O BEACON	2.2

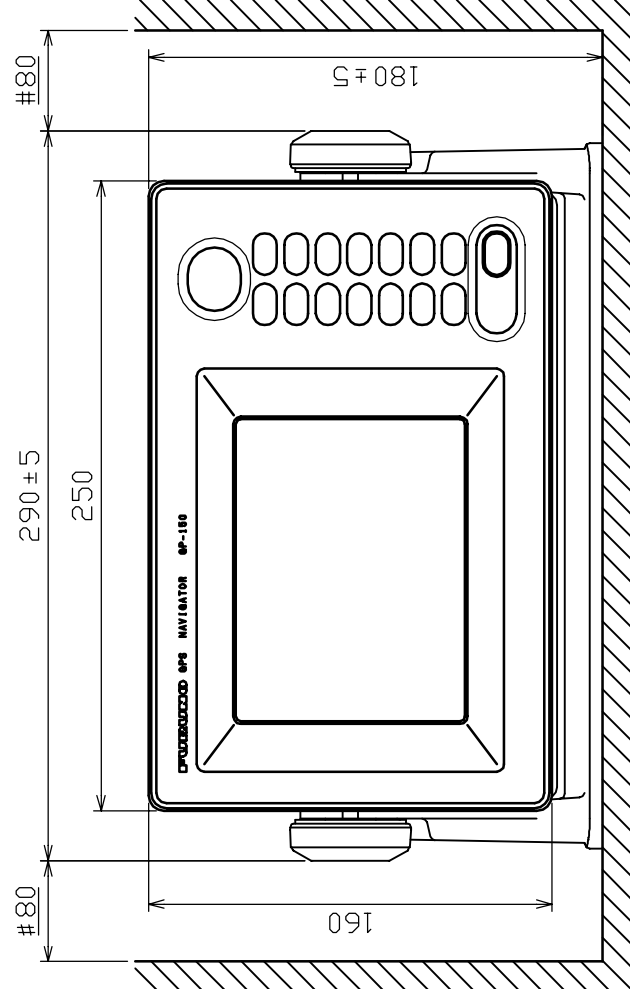
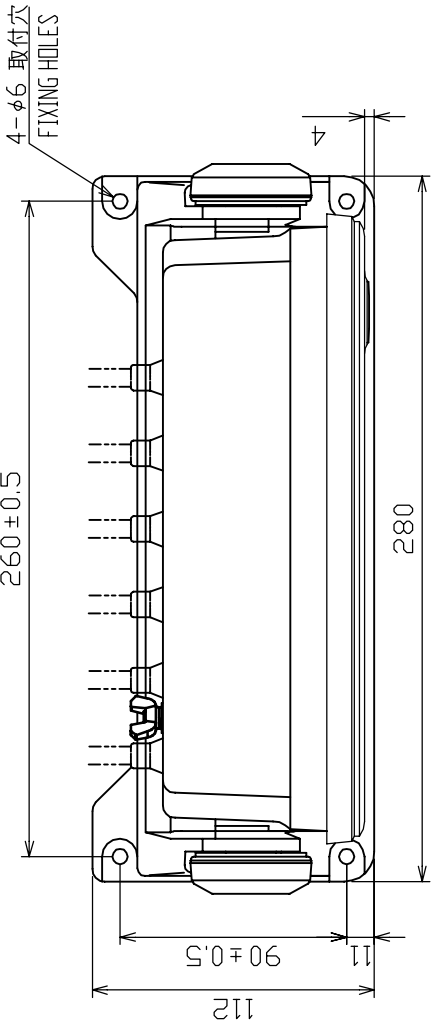
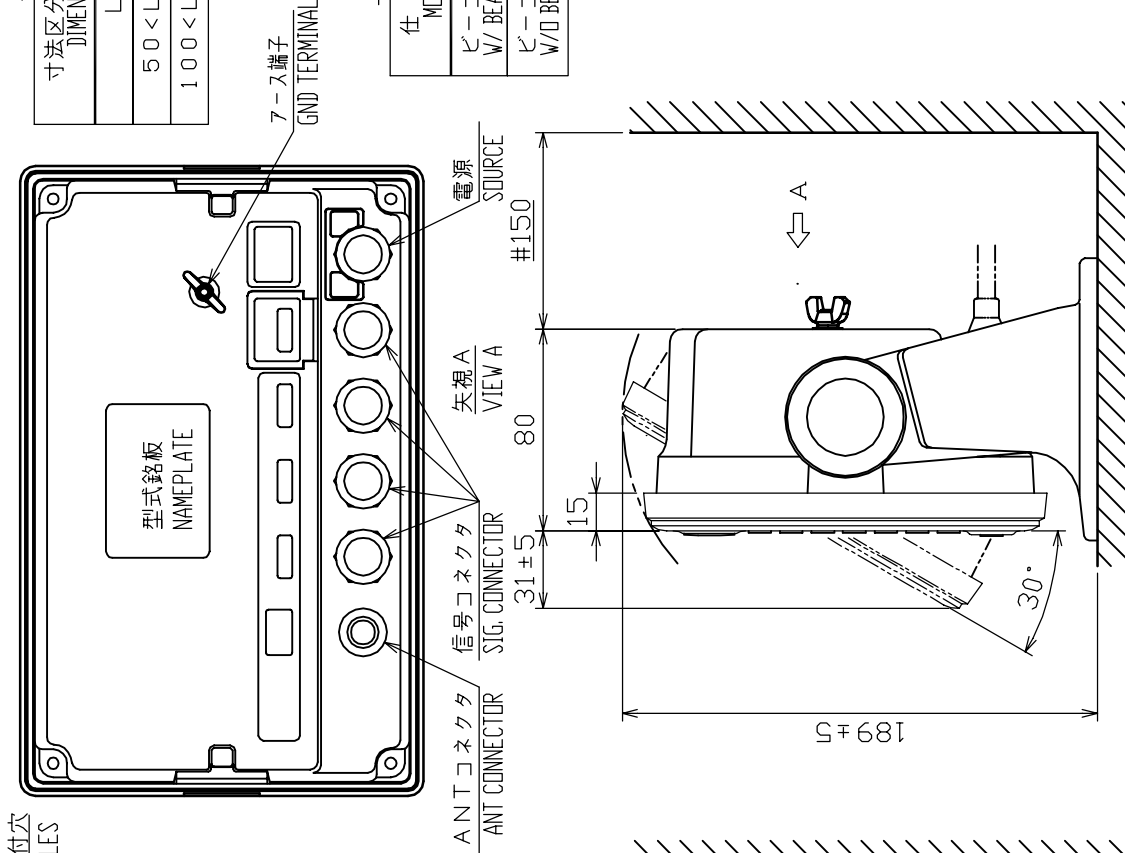

DRAWN Sep.15.105.E.MIYOSHI	TITLE GP-150
CHECKED TAKAHASHI	名称 受信演算部 (卓上装備)
APPROVED	外寸図
SCALE 1/3	WAVE DISPLAY UNIT (TABLETOP MOUNT)
DWG No. C4440-G01-A	OUTLINE DRAWING

- 注記 1) #印寸法は最小サービスクリアランスとする。
 2) 指定外の寸法公差は表1による。
 3) 取付用ネジは+トラスタップピンネジ呼び径5×20を使用のこと。
- NOTE 1. # MINIMUM SERVICE CLEARANCE.
 2. TABLE 1 INDICATES TOLERANCE OF DIMENSIONS WHICH IS NOT SPECIFIED.
 3. USE SELF-TAPPING SCREWS 5x20 FOR FIXING THE UNIT.

表 1 TABLE 1

寸法区分 (mm) DIMENSIONS	公差 (mm) TOLERANCE
L ≤ 50	± 1.5
50 < L ≤ 100	± 2.5
100 < L ≤ 500	± 3

表 2 TABLE 2

仕様 MODEL	質量 (kg±10%) MASS
ビーコン有り W/ BEACON	2.4
ビーコン無し W/O BEACON	2.2

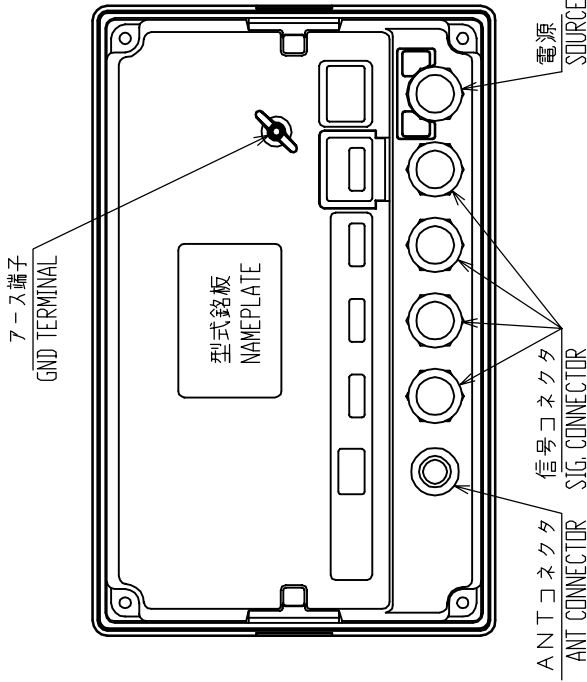
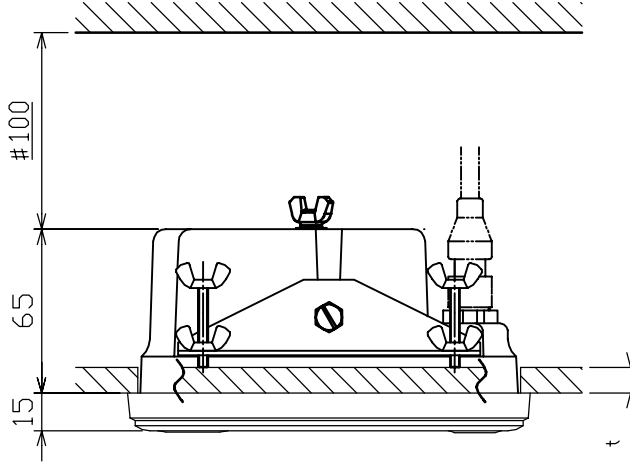
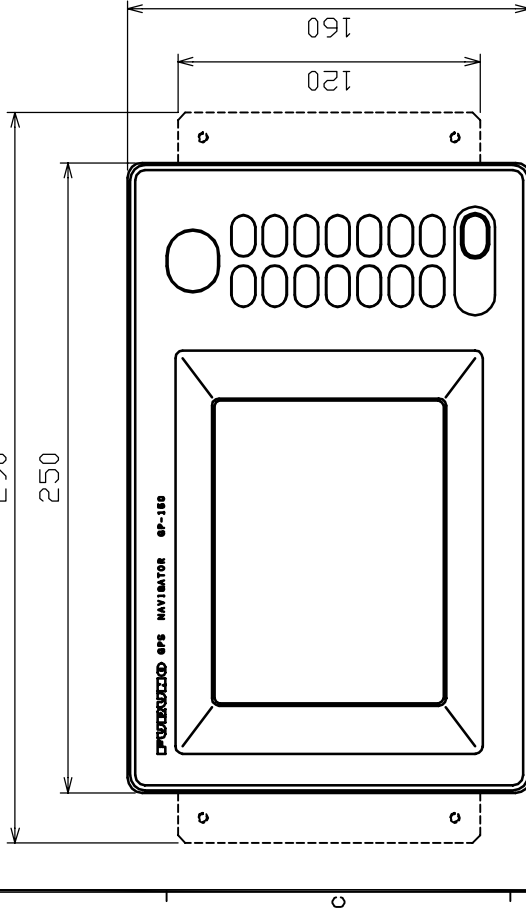
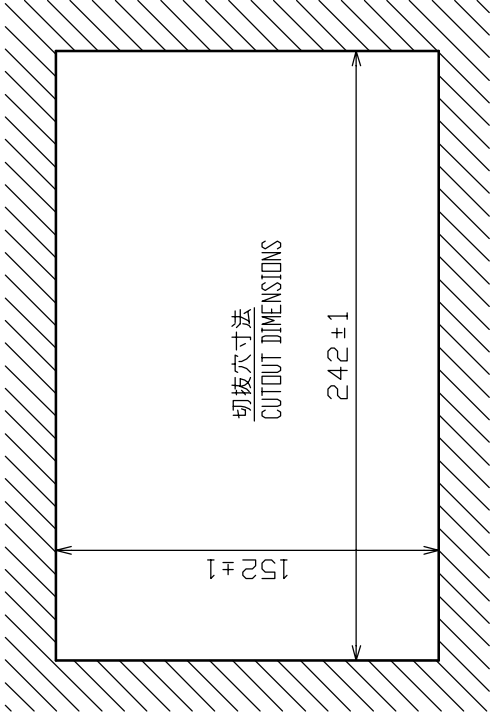

注 記 1) # 印寸法は最小サービス空間寸法とする。

2) 指定外の寸法公差は表 1 による。

3) 壁の厚さ (t) は、1 2以下とする。

NOTE 1. #: MINIMUM SERVICE CLEARANCE.

2. TABLE 1 INDICATES TOLERANCE OF DIMENSIONS WHICH IS NOT SPECIFIED.

3. THICKNESS OF BULKHEAD (t): t ≤ 12.

DRAWN CHECKED APPROVED SCALE DWG No	Sep. 15. 05. E.MIYOSHI TAKAHASHI MSS 1/3 C4440-G02-A	TABLE 2 表 2参照 TABLE 2	GP-150
TITLE	名 称	受信演算部 (埋込装備 S)	
	外寸図		
	WAVE	DISPLAY UNIT (FLUSH MOUNT S)	
		OUTLINE DRAWING	

表 1 TABLE 1

寸法区分 (mm) DIMENSIONS	公差 (mm) TOLERANCE
L ≤ 50	± 1.5
50 < L ≤ 100	± 2.5
100 < L ≤ 500	± 3

表 2 TABLE 2

仕様 MODEL	質量 (kg±10%) MASS
ビーコン有り W/ BEACON	2.4
ビーコン無し W/O BEACON	2.2

切抜穴寸法
CUTOUT DIMENSIONS

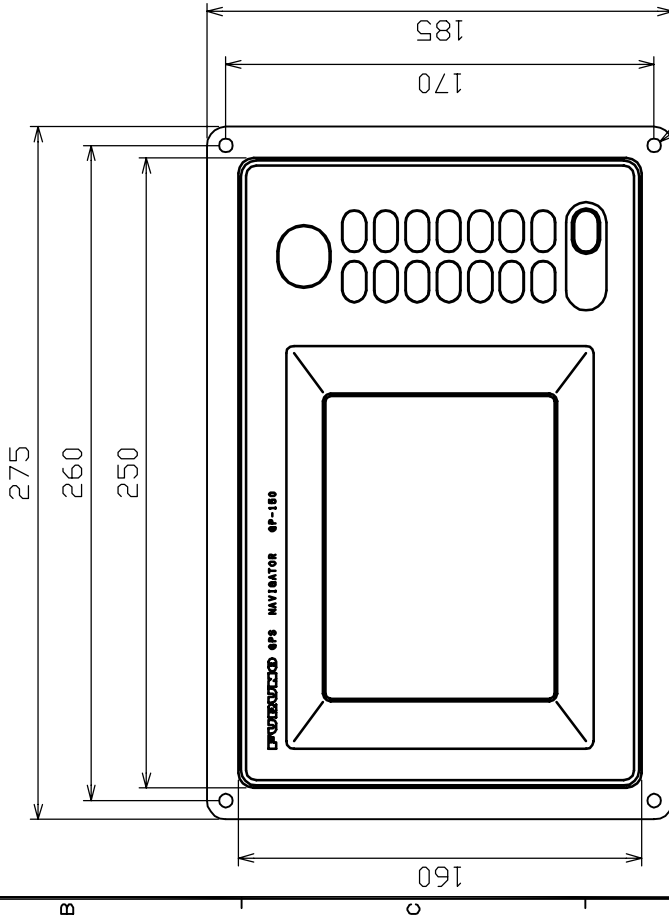
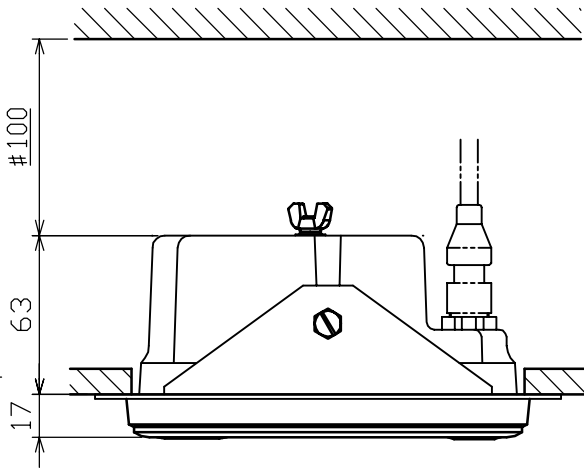
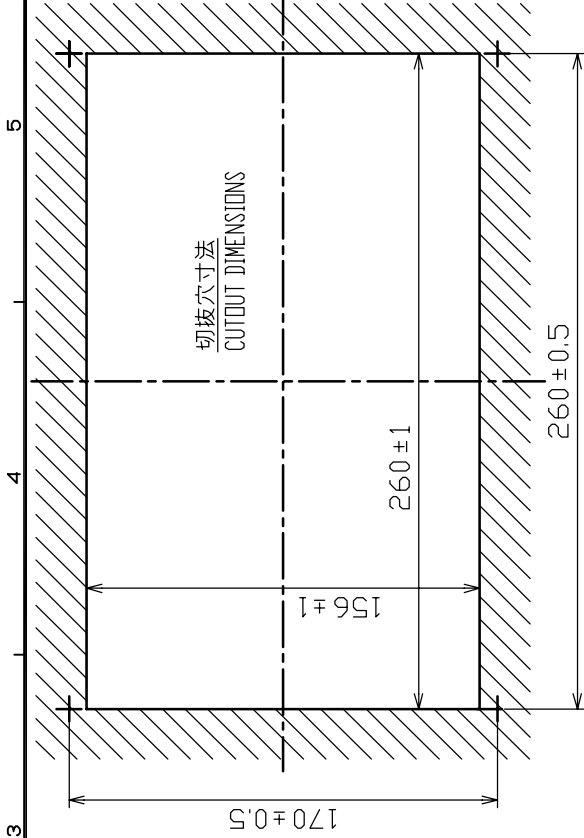

- 注記 1) #印寸法は最小カービス空間寸法とする。
 2) 指定外の寸法公差は表 1 による。
 3) 取付用ネジは + トラスタップピンネジ呼び径 5 × 2.0 を使用のこと。

NOTE 1. # MINIMUM SERVICE CLEARANCE.

2. TABLE 1 INDICATES TOLERANCE OF DIMENSIONS WHICH IS NOT SPECIFIED.

3. USE SELF-TAPPING SCREWS 5x2.0 FOR FIXING THE UNIT.

7-ス端子(M4)
GND TERMINAL

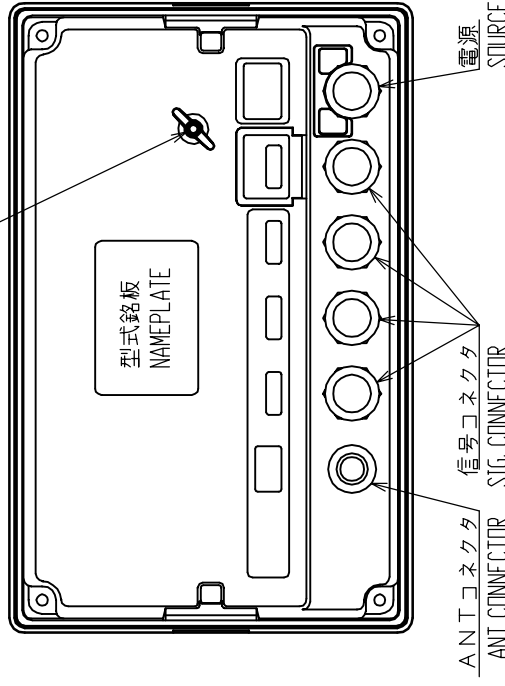

DRAWN	Sep.15.05.E.MYDOSHII	TITLE	GP-150
CHECKED	TAKAHASHI, I	名称	受信演算部 (埋込装備 F)
APPROVED		外寸図	
SCALE	1/3	WAVE	DISPLAY UNIT (FLUSH MOUNT F)
DATE	C4440-G03-A	OUTLINE DRAWING	

取付位置
MOUNTING LOCATION

他の機器のアンテナから下の図の距離以上離す。
THIS FIGURE SHOWS THE SEPARATION DISTANCES FROM OTHER ANTENNAS TO AVOID MUTUAL INTERFERENCE.

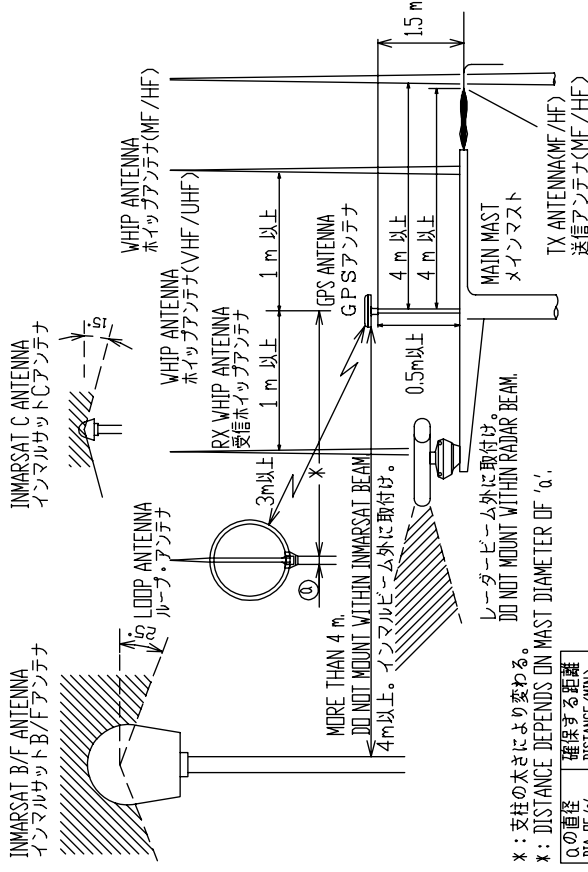

B) スタンションやパルピルにつけると

レール用アンテナベース No.13-RCS160
(取付可能レール直径: φ19~φ32)
(コード番号: 000-806-114)

HANDRAIL MOUNTING
USE HANDRAIL MOUNTING BASE No.13-RCS160
(CODE No.000-806-114, OPTION).
THE DIAMETER OF THE HANDRAIL MAY BE FROM φ19mm TO φ32mm.

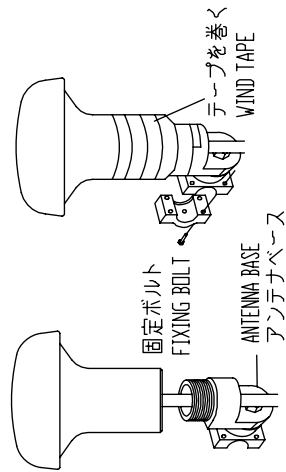

注記 1) パイプやアンテナベースはアンテナユニットにねじ込んだ後に固定する。
2) アンテナを固定するときはパイプ (アンテナベース) をアンテナにねじ込むこと。
アンテナ側をねじるとコネクタ部やケーブルに無理がかかり、故障の原因となる。

NOTE 1. FASTEN PIPE(ANTENNA BASE) TO ANTENNA UNIT FIRST THEN FIX THEM TO MAST OR HANDRAIL.
2. WHEN FIXING ANTENNA, TURN PIPE OR ANTENNA BASE; NOT THE ANTENNA.
TURNING THE ANTENNA MAY TWIST THE CABLE AND PLACE STRESS ON CONNECTOR.

A) マストへの取付け
MAST MOUNTING

α) パイプのみを使うとき
USE A PIPE ONLY.

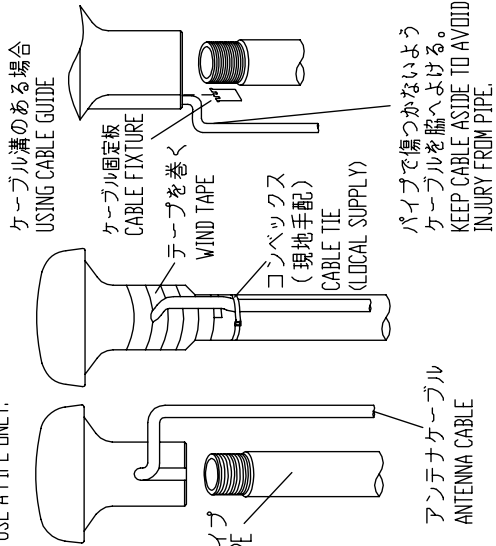
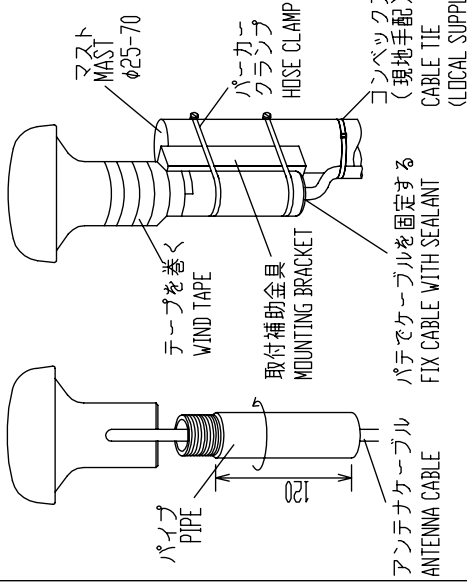

C) 取付ける場所が傾斜しているとき
ANTENNA BASE MOUNTING

オプションのアンテナベースを使う。
USE OPTIONAL ANTENNA BASE.

傾斜 INCLINATION	取付け方法 MOUNTING METHOD	アンテナベース型式 ANT. BASE TYPE	コード番号 CODE No.
-5° - 33°		直型アンテナベース RIGHT ANGLE ANTENNA BASE No.13-QA330	000-803-239
32° - 65°		L型アンテナベース L-TYPE ANTENNA BASE No.13-QA310	000-803-240
65° - 98°			

アンテナベース基部
MOUNTING DIMENSIONS OF ANTENNA BASE.

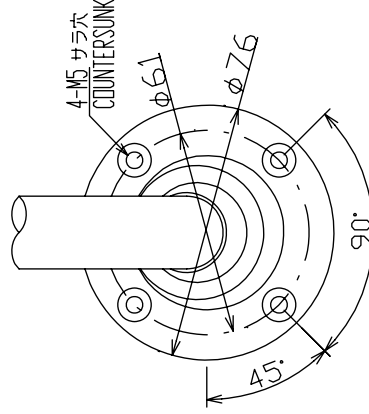

A

B

C

D



表1 TABLE 1

寸法区分(mm) DIMENSION	公差(mm) TOLERANCE
$L \leq 50$	± 1.5
$50 < L \leq 100$	± 2.5
$100 < L \leq 500$	± 3

1-14UNS1B

ねじ山数 (25.4mmにつき) : 14
 ピッチ : 1.8143 mm
 オネジ有効長さ : 19 mm以上
 オネジ有効径 : 24.17mm

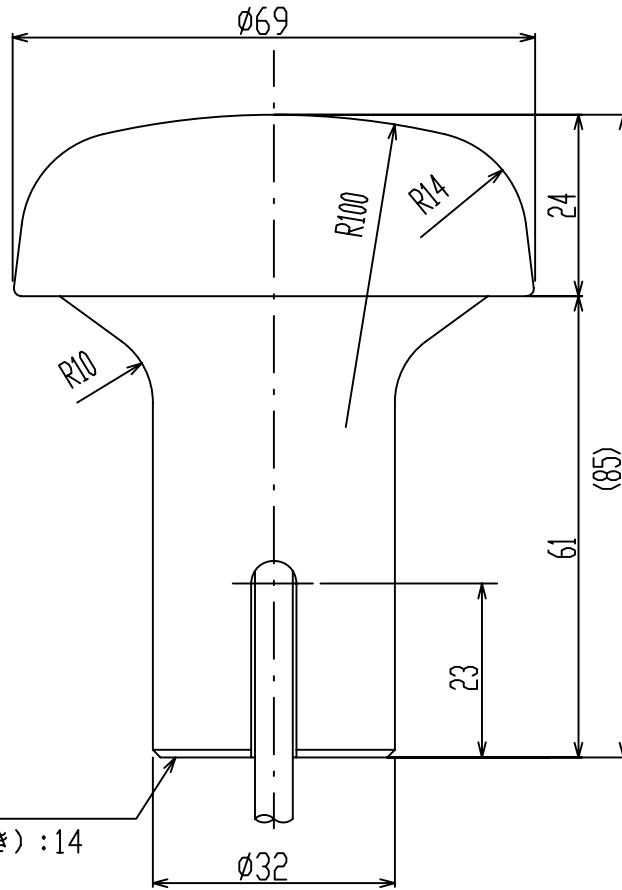
THREAD PER 25.4mm (1 INCH): 14
 PITCH: 1.8143 mm
 THREAD LENGTH: 19 mm OR MORE
 PITCH DIAMETER: 24.17mm



表2 TABLE 2

型式 TYPE	ケーブル長(m) CABLE LENGTH	プラグ PLUG	質量(kg±10%) MASS
GPA-017	10	TNC-P-3	0.6
GPA-017S	0.2	TNC-J-3	0.15

注記

指定外の寸法公差は表1による。

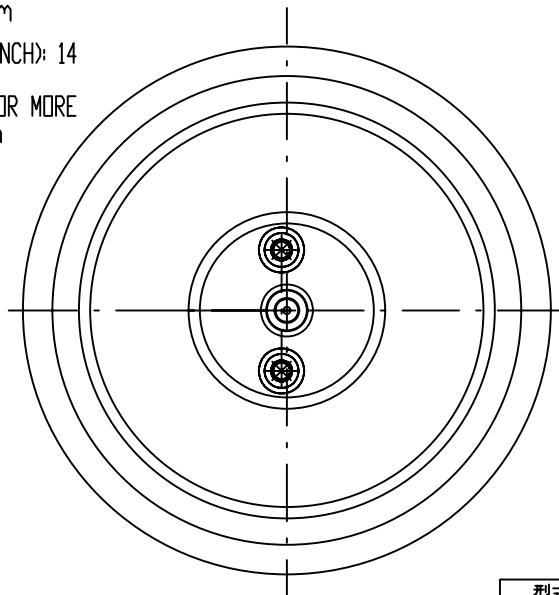
NOTE

TABLE 1 INDICATES TOLERANCE OF DIMENSIONS WHICH IS NOT SPECIFIED.

DRAWN Mar. 27 '07 T.YAMASAKI		TITLE GPA-017/017S
CHECKED Mar. 27 '07 T.TAKENO		名称 空中線部
APPROVED Mar. 27 '07 R.Esumi		外寸図
SCALE 1/1	MASS TABLE 2 表2参照	NAME ANTENNA UNIT
DWG.No. C4384-G04-L		OUTLINE DRAWING

表1 TABLE 1

寸法区分 (mm) DIMENSION	公差 (mm) TOLERANCE
$L \leq 50$	± 1.5
$50 < L \leq 100$	± 2.5
$100 < L \leq 500$	± 3

* 1.2m以下のホイップを使用のこと。
決してこれ以上のものを使用しないこと。
* USE 1.2 m OR SHORTER WHIP.
DO NOT USE LONGER ONE.

アース線
GND WIRE (IV-2sq.)
(造船所手配)
(SHIPYARD SUPPLY)

シール剤を
塗布する
APPLY SILICONE
SEALANT

アースボルト
(造船所手配)
M6-M8
STUD BOLT
(SHIPYARD SUPPLY)

マスト
MAST

1-14UNS1B

ねじ山数(25.4mmにつき): 14
ピッチ: 1.8143 mm
オネジ有効長さ: 19 mm以上
オネジ有効径: 24.17 mm

THREADS PER INCH (25.4mm): 14
PITCH: 1.8143 mm
THREAD LENGTH: 19 mm OR MORE
PITCH DIAMETER: 24.17 mm

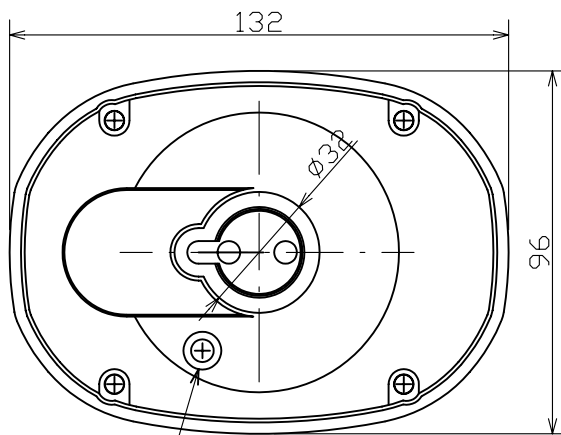

アース端子
GND TERMINAL

表2 TABLE 2

型式 TYPE	ケーブル長(m) CABLE LENGTH	プラグ PLAG	質量(kg±10%) MASS
GPA-018	10	TNC-P-3	0.79
GPA-018S	0.2	TNC-J-3	0.35

注記 1) 指定なき寸法公差は表1による。
NOTE 1. TABLE 1 INDICATES TOLERANCE OF DIMENSIONS.

DRAWN Mar. 9 '05 I.YAMASAKI	TITLE GPA-018/018S
CHECKED Mar. 9 '05 H.HAYASHI	名称 空中線部
APPROVED Feb. 19, '03 Y. Kimura	外寸図
SCALE 1/2 MASS TABLE 2 表2参照	NAME ANTENNA UNIT
DWG. No. C4385-G01-L	OUTLINE DRAWING

寸法区分(mm) DIMENSION	公差(mm) TOLERANCE
L ≤ 50	±1.5
50 < L ≤ 100	±2.5
100 < L ≤ 500	±3

表1 TABLE 1

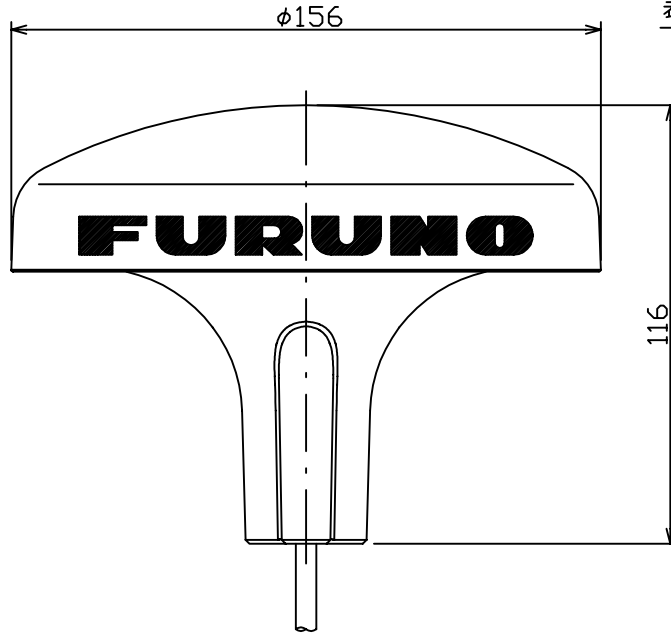

1-14UNS1B

ねじ山数(25.4mmにつき): 14
 ピッチ: 1.8143 mm
 オネジ有効長さ: 15.17 mm
 オネジ有効径: 24.17 mm

THREAD PER 25.4mm (1 INCH): 14
 PITCH: 1.8143 mm
 THREAD LENGTH: 15.17 mm
 PITCH DIAMETER: 24.17 mm

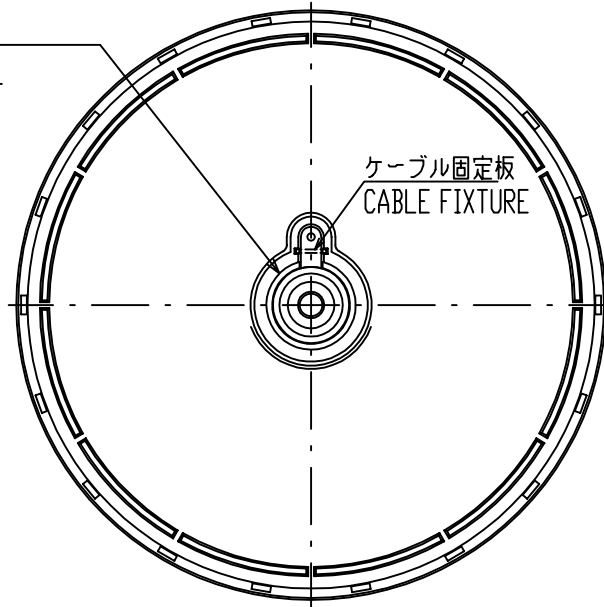

型式 TYPE	ケーブル長(m) CABLE LENGTH	プラグ PLAG	質量 (kg±10%) MASS
GPA-019	10	TNC-P-3	1.0
GPA-019S	0.2	TNC-J-3	0.54

表2 TABLE 2

注記: 指定外の寸法公差は表1による

NOTE: TABLE 1 INDICATES TOLERANCE OF DIMENSIONS.

DRAWN Feb. 19 '03 T.YAMASAKI	TITLE GPA-019/019S
CHECKED Feb. 19 '03 Y.KIMURA	名称 空中線部
APPROVED Feb. 19, '03 <i>Y. Kimura</i>	外寸図
SCALE 1/2 MASS TABLE 2 表2参照	NAME ANTENNA UNIT
DWG. No. C4400-G01-F	OUTLINE DRAWING



表1 TABLE 1

寸法区分(mm) DIMENSION	公差(mm) TOLERANCE
0 < L ≤ 50	±1.5
50 < L ≤ 100	±2.5
100 < L ≤ 500	±3

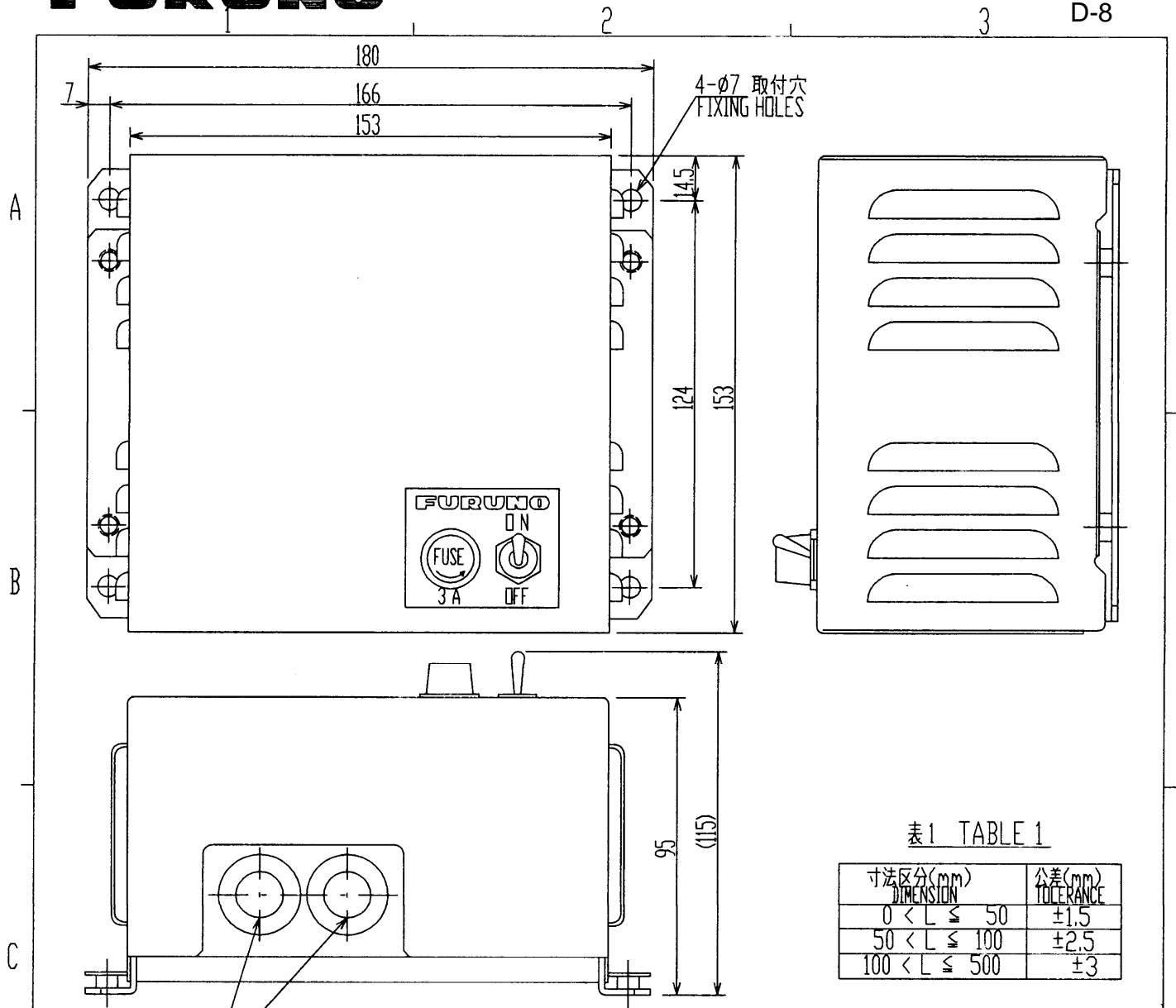
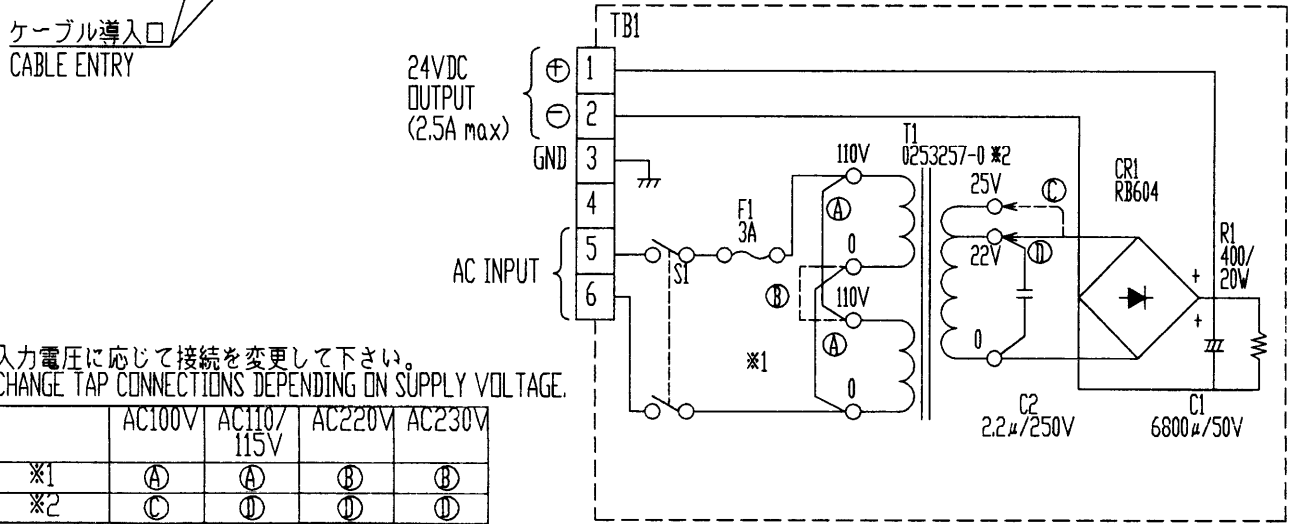

入力電圧に応じて接続を変更して下さい。
CHANGE TAP CONNECTIONS DEPENDING ON SUPPLY VOLTAGE.

	AC100V	AC110/115V	AC220V	AC230V
※1	Ⓐ	Ⓐ	Ⓑ	Ⓑ
※2	Ⓒ	Ⓓ	Ⓓ	Ⓓ

DRAWN Sep. 14 '01 T.YAMASAKI		TITLE PR-62
CHECKED S. Y. K.		名称 整流器
APPROVED S. Y. K.		外寸図
SCALE 1/2 MASS ±10% 3 kg		NAME RECTIFIER
DWG.No. C5003-034-E		OUTLINE DRAWING

ECF

(Elemental Chlorine Free)

The paper used in this manual
is elemental chlorine free.

FURUNO ELECTRIC CO., LTD.

9-52 Ashihara-cho,
Nishinomiya, 662-8580, JAPAN

Telephone : +81-(0)798-65-2111

Fax : +81-(0)798-65-4200

• FURUNO Authorized Distributor/Dealer

All rights reserved. Printed in Japan

Pub. No. IME-44400-D

(HIMA) GP-150

A : FEB . 2006

D : NOV . 06, 2008



* 0 0 0 1 5 8 0 1 6 1 3 *