

SPECIFICATIONS OF SC-30

- Accuracy**
Attitude 1.0° rms (Heading), 1.0° rms (Roll & Pitch)
GPS 10 m (95%)
WAAS 3 m (95%)
- Follow-up** 45°/s rate-of-turn
- Settling time** 3 min
- Interface**
Number of ports
SC-30: 1 port in NMEA2000®
IF-NMEASC: 2 ports in IEC 61162-1 (option)
1 port in AD-10
1 port in Analog
Serial data sentence
25, 100, 200 ms, 1, 2 s data rate:
HDT, HDG, HVE, HDM (Heading), ATT (Pitch and Roll)
1, 2 s data rate:
VTG, GGA, ZDA(UTC), RMC
- Receiver Type** Twelve discrete channels, WAAS 1 ch
C/A code, all-in-view
- Receive Freq** L1 (1575.42 MHz)

POWER SUPPLY 12-24 VDC
(SC-30: Load Equivalency MAX 10 (= 500 mA))

ENVIRONMENT
Temperature
SC-30: -25°C to +70°C
IF-NMEASC: -15°C to +55°C
Waterproofing
SC-30: IEC60529 IP56
IF-NMEASC: IEC60529 IP20

- EQUIPMENT LIST**
Standard
- Antenna Unit SC-30 with 6m cable 1 unit
 - Installation materials
- Option**
- Interface Unit IF-NMEASC
 - Cable Assembly MJ-A10SPF0015 15 m/30 m
 - Cable Assembly MJ-A10SPF0017 15 m/30 m (Micro C/PWR)
 - Bird-Repellent Fixture OP20-36

Sensor Unit SC-30

2.5kg 5.5lb

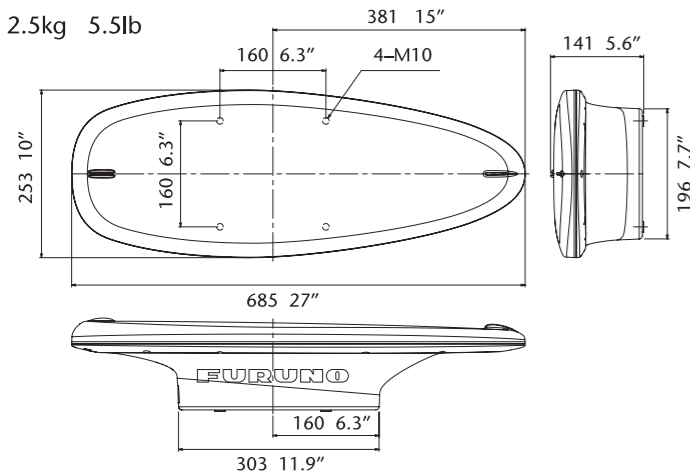

Interface Unit IF-NMEASC (Option)

1.0kg 2.2lb

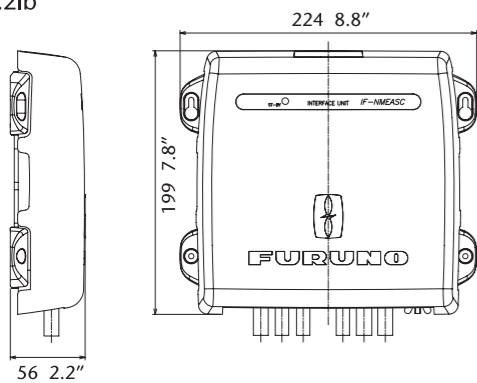

NMEA 2000® is a registered trademark of the National Marine Electronics Association.

INTERCONNECTION DIAGRAM

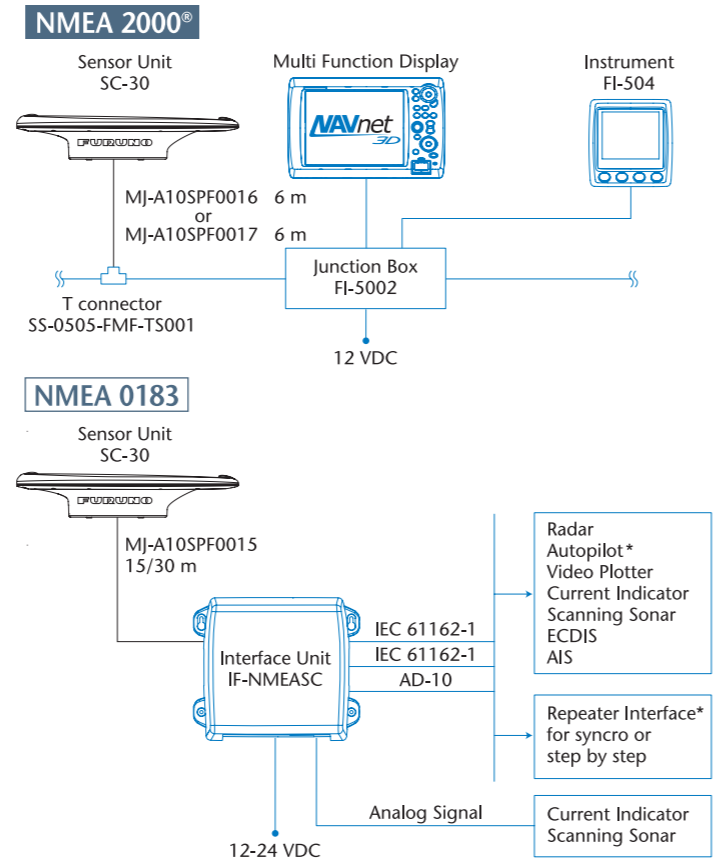

* For further info, contact our depot
— option or local supply

TRADEMARK REGISTERED
SPECIFICATIONS SUBJECT TO CHANGE WITHOUT NOTICE



FURUNO

SC-30

SATELLITE COMPASS



FURUNO ELECTRIC CO., LTD.
Nishinomiya, Hyogo, Japan
Phone: +81 (0)798 65-2111
Fax: +81 (0)798 65-4200, 66-4622

FURUNO FRANCE S.A.S.
Bordeaux-Mérignac, France
Phone: +33 5 56 13 48 00
Fax: +33 5 56 13 48 01

FURUNO NORGE A/S
Ålesund, Norway
Phone: +47 70 102950
Fax: +47 70 102951

FURUNO POLSKA Sp. Z o.o.
Gdynia, Poland
Phone: +48 58 669 02 20
Fax: +48 58 669 02 21

FURUNO DEUTSCHLAND GmbH
Rellingen, Germany
Phone: +49 4101 838 0
Fax: +49 4101 838 111

FURUNO ESPAÑA S.A.
Madrid, Spain
Phone: +34 91-725-90-88
Fax: +34 91-725-98-97

FURUNO SVERIGE AB
Västra Frölunda, Sweden
Phone: +46 31-7098940
Fax: +46 31-497093

FURUNO FINLAND OY
Espoo, Finland
Phone: +358 9 4355 670
Fax: +358 9 4355 6710

LLC "FURUNO EURUS"
St. Petersburg, Russian Federation
Phone: +7 812 767 15 92
Fax: +7 812 766 55 52



07105U Printed in Japan
Catalogue No. N-869a



www.furuno.co.jp

Revolutionary 2-antenna satellite compass provides highly accurate attitude data to navigation systems.

The SC-30 satellite compass provides highly accurate attitude information for navigation equipment such as radar, plotter, autopilot, AIS, fish finder and sonar. It can be used for a wide range of applications on any type of vessel. The SC-30 comes with a compact GPS antenna a built-in processor. This all-in-one system delivers incredibly accurate heading and roll & pitch information as well as heaving information, GPS position, SOG (Speed Over Ground), COG (Course Over Ground) and ROT (Rate Of Turn) data. Employing a two-antenna system with a 3-axis rate gyro and acceleration sensors, the SC-30 enables high-speed response capability. Advanced digital signal processing techniques compute accurate heading based on sensor data. NMEA 2000® interface is standard for simple installation, while the optional interface unit IF-NMEASC is available for conventional NMEA0183, AD-10 and contact closure.



SC-30
SATELLITE COMPASS

- ▶ Stylish design to complement the appearance of recreational boats
- ▶ All-in-one system for simple, space-saving installation
- ▶ Heading accuracy of 1.0° rms
- ▶ Short start-up time of 3 minutes

- ▶ Excellent follow-up rate of 45°/s exceeds requirements for high speed craft
- ▶ Free from regular maintenance
- ▶ NMEA2000® interface standard

Revolutionary 2-antenna and rate sensor system

In order to calculate roll & pitch data, a satellite compass requires two vectors. The new SC30 employs a 2-antenna system that calculates a single vector while the 3-axis rate gyro and acceleration sensors add the 2nd vector. This configuration enables the SC-30 to calculate highly accurate roll and pitch data without using a third antenna.

* SC-30 uses the LAMBADA algorithm developed by Prof. Teussen, Delft University of Technology, the Netherlands.

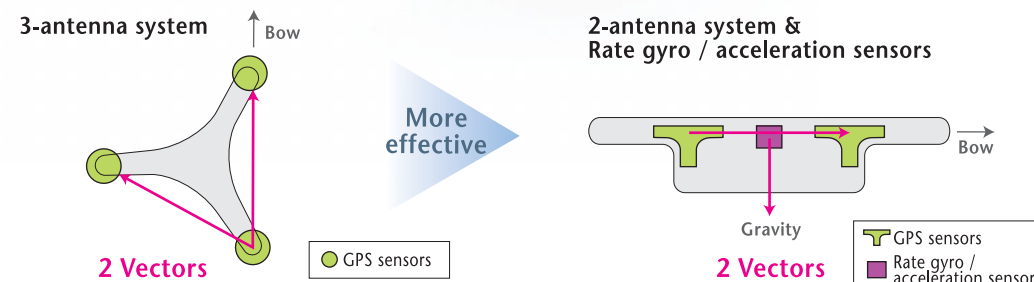

RADAR — NavNet 3D/NavNet vx2/FR-8002 series/etc

True Motion Echo Trail

True echo trail is available when the SC-30 is connected to FURUNO radar. True echo trails are helpful for determining own ship's movement as well as that of other vessels. Heading accuracy and sensing speed ensures that trails are displayed in smooth lines.

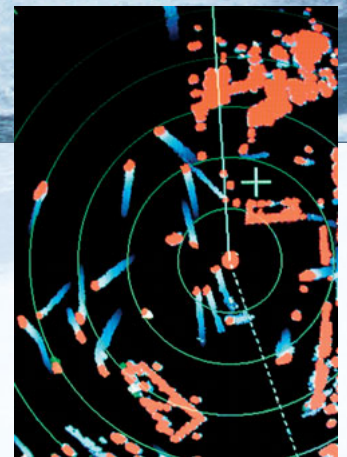

FISH FINDER — NavNet 3D/FCV-30/FCV-1200/etc

Heaving Compensation ON

In rough sea conditions, the SC-30 provides compensation data to fish finder systems to present a display free from undulations due to vessels heaving.

Heaving Compensation OFF

The bottom and fish echoes appear to be wavering due to heaving of the vessel even though the seabed is flat.

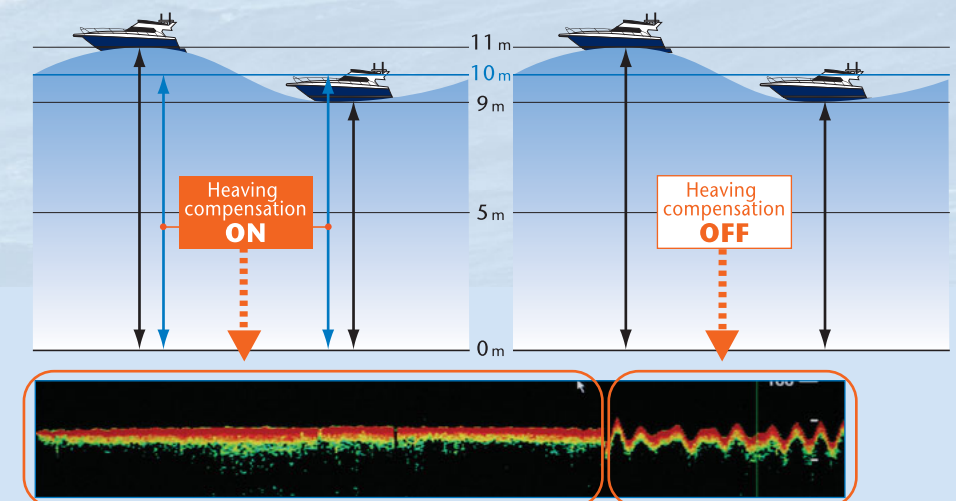

SONAR — FSV-84/FSV30/CH-300/CH-270/CH-250/CSH-5L/etc

Pitch And Roll Compensation

The Pitch and Roll compensation data allows FURUNO sonar systems to display an unwavering presentation and facilitates stable detection, even in foul weather conditions.

Beam Stabilizer OFF

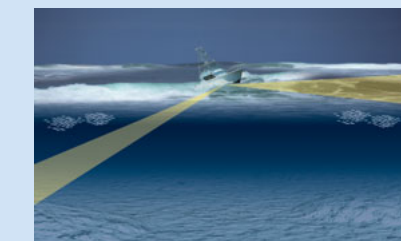

Beam Stabilizer ON

