

SC30 powered through NN3D (6 meter antenna cable)

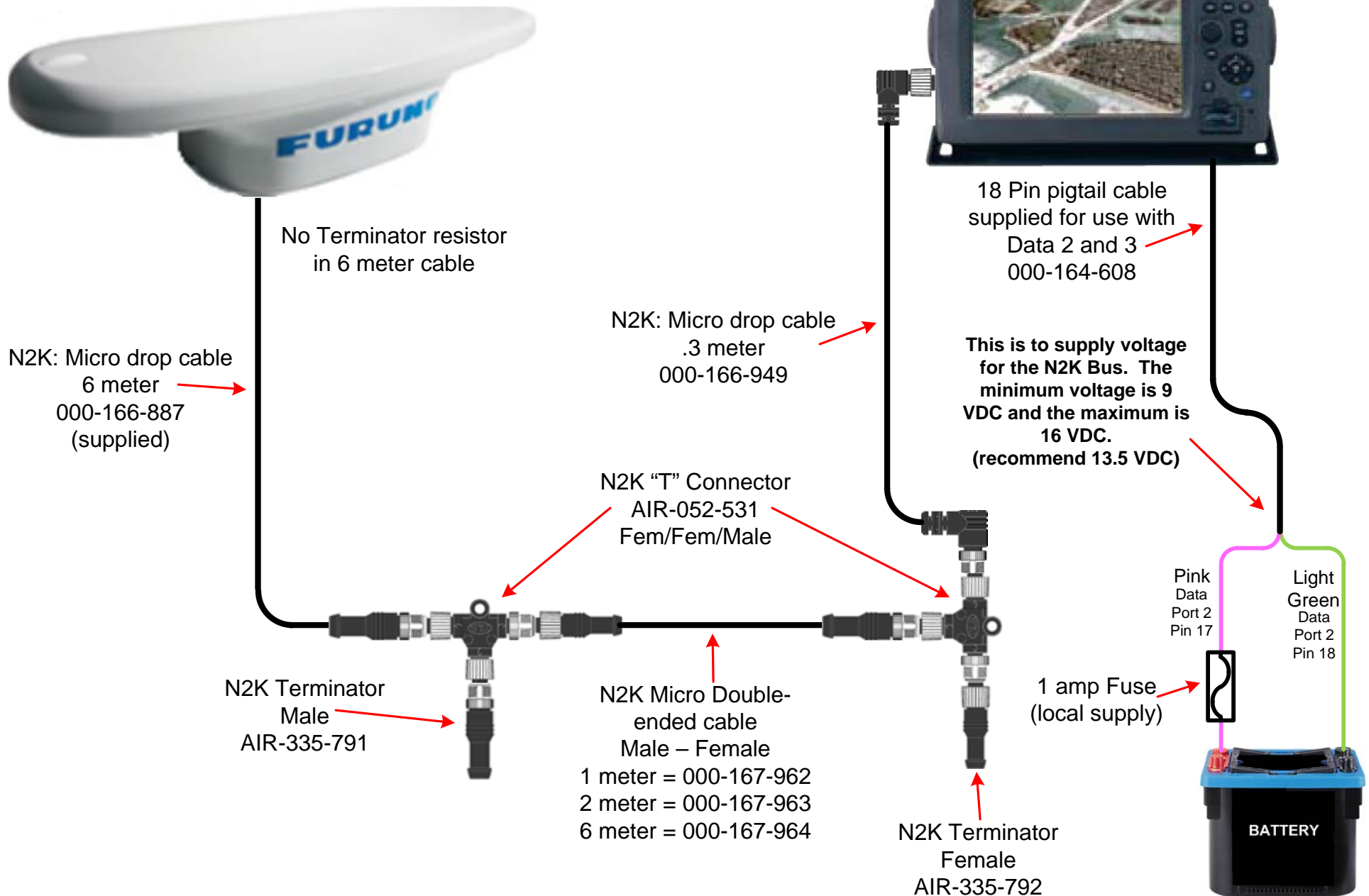

SC30 powered through NN3D (15 or 30 meter antenna cable)



N2K: SC30 Backbone cable
 15 meter = 000-166-891
 30 meter = 000-166-892
(Terminator resistor included in both of these cable lengths)

N2K: Micro Drop cable .3 meter
 000-166-949



18 Pin pigtail cable supplied for use with Data 2 and 3
 000-164-608

This is to supply voltage for the N2K Bus. The minimum voltage is 9 VDC and the maximum is 16 VDC. (13.5 VDC recommended)

N2K: Field Connector Male
 AIR-335-781

N2K "T" Connector
 AIR-052-531
 Fem/Fem/Male

- Pin 1 = Shield
- Pin 2 = Red
- Pin 3 = Black
- Pin 4 = White
- Pin 5 = Blue

N2K Terminator Female
 AIR-335-792

Pink Data Port 2 Pin 17
 Light Green Data Port 2 Pin 18

1 amp Fuse (local supply)



The Purple, Yellow and Green wires are not used for this connection. They need to be cut back, isolated and taped so they don't short to any other wires and cause equipment damage.

SC30 connection to DRS Dome and NavNet 3D (6 meter cable)



Use the included 3 hole gasket for this installation application.

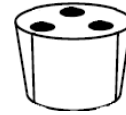

N2K Micro drop cable 6 meter
000-166-887
(supplied)
No Terminator resistor in 6 meter cable

Cut N2K connector off of SC30 cable and connect the wires to the green N2K connector inside the DRS2D or DRS4D. Match the wire colors to the colors shown in the DRS Connector close-up.

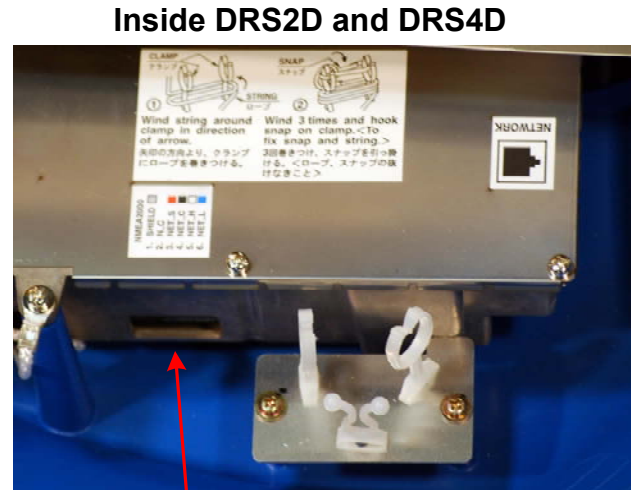

Inside DRS2D and DRS4D



Ethernet and power

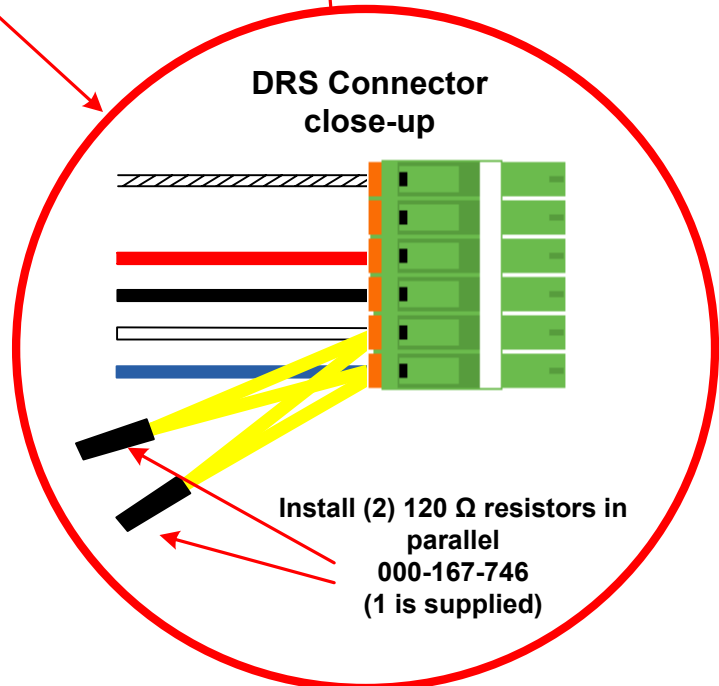

SC30 connection to DRS Dome and NavNet 3D (15 or 30 meter antenna cable)



Use the included 3 hole gasket for this installation application.

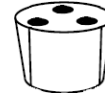

N2K: SC30 Backbone cable
15 meter = 000-166-891
30 meter = 000-166-892
(Terminator resistor included in both of these cable lengths)



Inside DRS2D and DRS4D

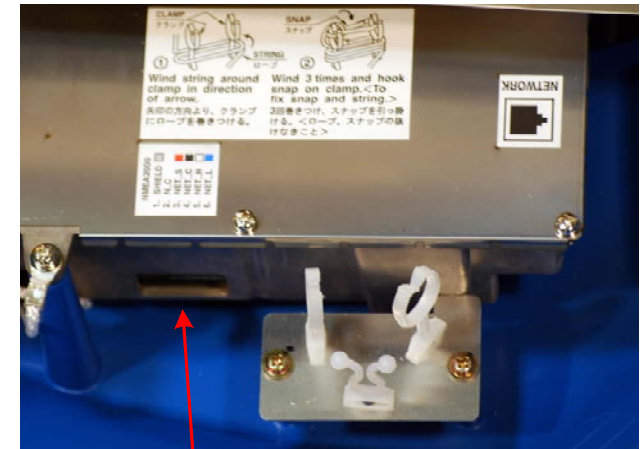

Connect the wires to the green N2K terminal inside the DRS Dome. Match the wire colors to the colors shown in the DRS Connector close-up. The Purple, Yellow and Green wires in this cable are not used for this connection. They need to be cut back, isolated and taped so they don't short to any other wires and cause equipment damage.



Ethernet and power

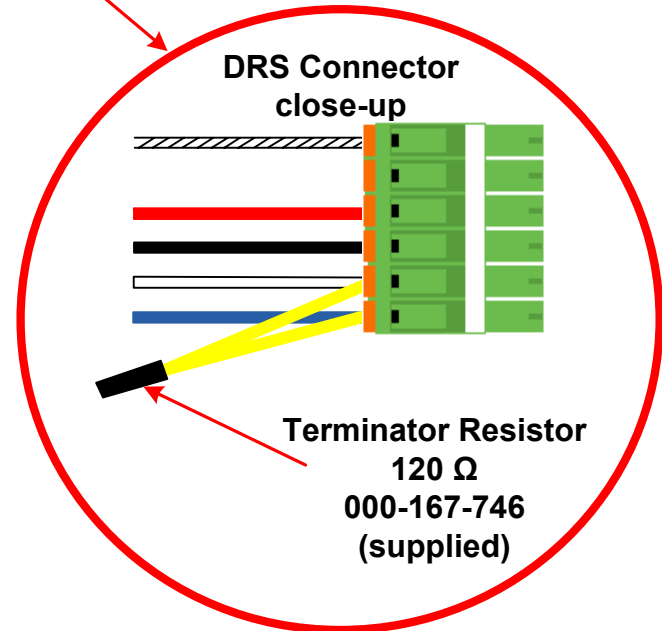

SC30 connection to DRS Gearbox and NN3D (6 meter cable)



N2K Micro drop cable 6 meter
000-166-887
(supplied)
No Terminator resistor in 6 meter cable

Use the included 3 hole gasket for this installation application.

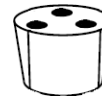

Inside DRS Gearbox

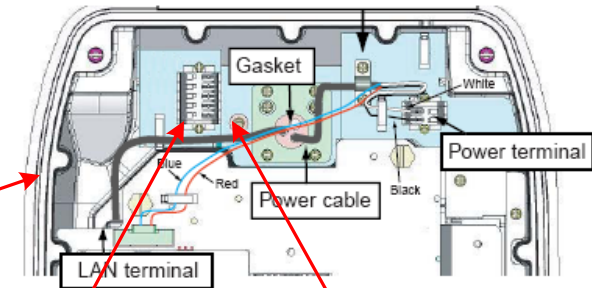

Attach crimp-lug to shield wire in N2K cable and fasten to screw on radar T/R chassis shown in image above and below.

Cut N2K connector off of cable and connect the wires to the gray N2K terminal inside the DRS Gearbox. Match the wire colors to the colors shown in the DRS Connector close-up.

DRS Connector close-up

Install (2) 120 Ω resistors in parallel
000-167-746
(1 is supplied)

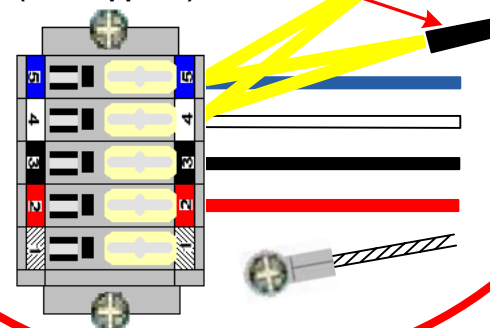

Ethernet

SC30 connection to DRS Gearbox and NN3D (15 or 30 meter antenna cable)



Use the included 3 hole gasket for this installation application.

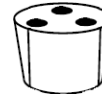

Inside DRS Gearbox

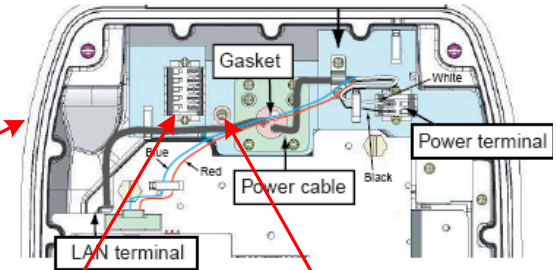

N2K: SC30 Backbone cable
15 meter = 000-166-891
30 meter = 000-166-892
(One terminator resistor is embedded in the SC30 connector end of these optional cables)

Connect the wires to the gray N2K terminal inside the DRS Gearbox. Match the wire colors to the colors shown in the DRS Connector close-up. The Purple, Yellow and Green wires in this cable are not used for this connection. They need to be cut back, isolated and taped so they don't short to any other wires and cause equipment damage.

Attach crimp-lug to shield wire in N2K cable and fasten to screw on radar T/R chassis shown in image above and below.



Ethernet/Power

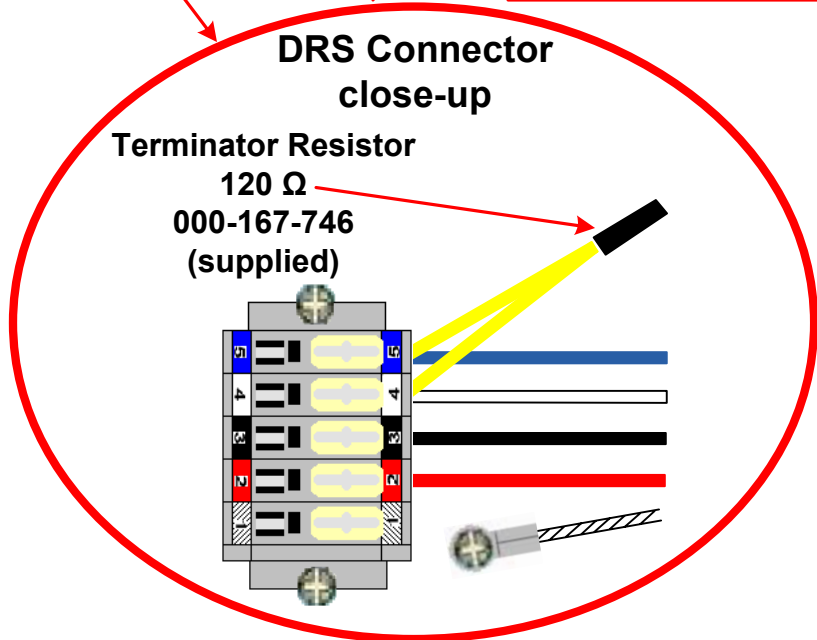

SC30 to FI5002 with FI505 instrument with NN3D (6 meter antenna cable)

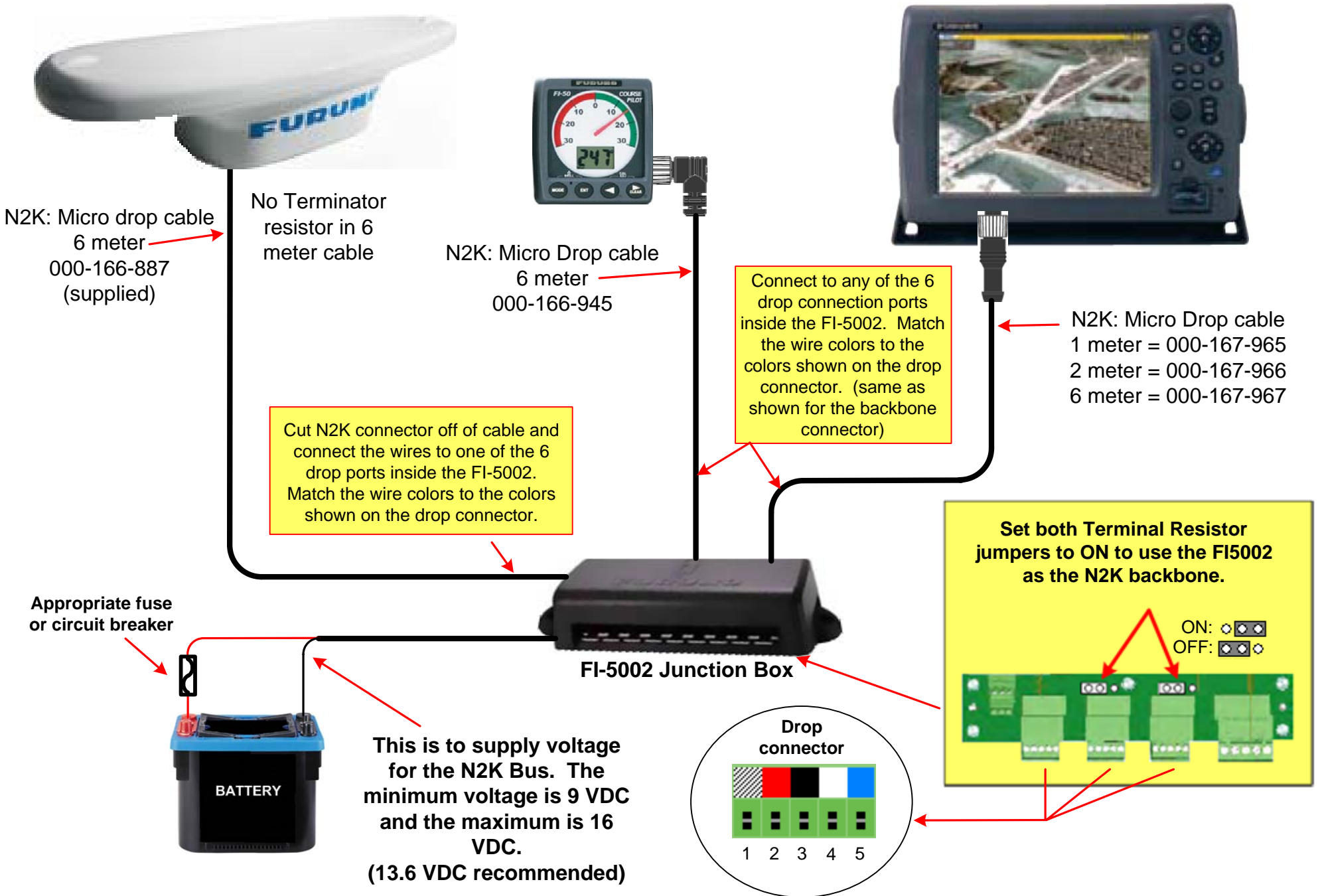

SC30 to FI5002 with FI505 instrument with NN3D (15 or 30 meter antenna cable)

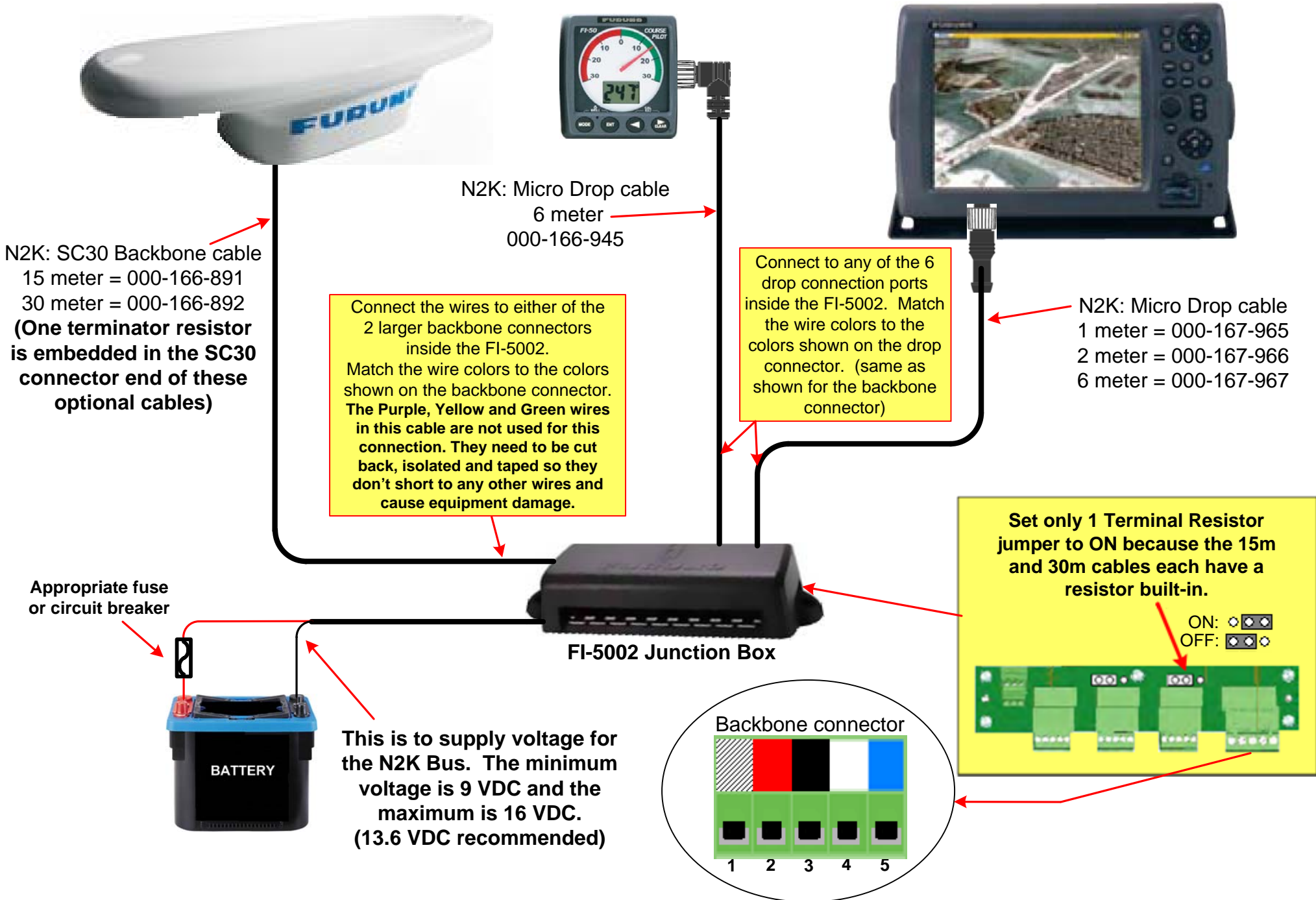

N2K: SC30 Backbone cable
15 meter = 000-166-891
30 meter = 000-166-892
(One terminator resistor is embedded in the SC30 connector end of these optional cables)

N2K: Micro Drop cable
6 meter = 000-166-945

Connect the wires to either of the 2 larger backbone connectors inside the FI-5002. Match the wire colors to the colors shown on the backbone connector. **The Purple, Yellow and Green wires in this cable are not used for this connection. They need to be cut back, isolated and taped so they don't short to any other wires and cause equipment damage.**

Connect to any of the 6 drop connection ports inside the FI-5002. Match the wire colors to the colors shown on the drop connector. (same as shown for the backbone connector)

N2K: Micro Drop cable
1 meter = 000-167-965
2 meter = 000-167-966
6 meter = 000-167-967

Appropriate fuse or circuit breaker



This is to supply voltage for the N2K Bus. The minimum voltage is 9 VDC and the maximum is 16 VDC. (13.6 VDC recommended)

FI-5002 Junction Box

Set only 1 Terminal Resistor jumper to ON because the 15m and 30m cables each have a resistor built-in.

ON:

OFF:

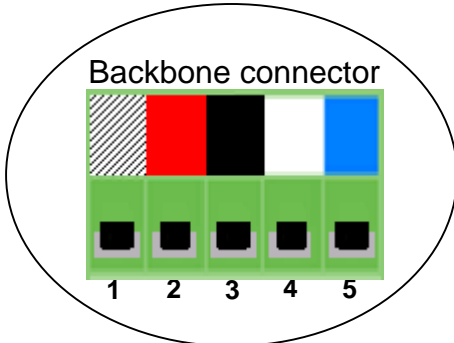

SC30 with IF-NMEASC



N2K: SC30 Backbone cable
 15 meter = 000-166-891
 30 meter = 000-166-892
(One terminator resistor is embedded in the SC30 connector end of these optional cables)

The IF-NMEASC has a built-in terminator resistor for the N2K (J7) port.

When connecting multiple N2K devices to J7, match like-colored wires together and connect to appropriate pins shown below.

NN3D MFD or Other N2K

N2K: Micro Drop cable
 1 meter = 000-167-965
 2 meter = 000-167-966
 6 meter = 000-167-967

