

# RUGGED.

## DOCKING STATIONS AND VEHICLE MOUNTS



### Ford Crown Victoria/Police Interceptor (1991- 2008)

Placement	Seat Configurations	Drilling Required	Pole	Height Adjustability	Weight	Height	Width	Depth
Passenger side on the floor - under seat	Bucket/Bench/60-40 split	<b>No</b> - attaches to seat studs: <i>Ford Crown Victoria/Police Interceptor (1991-2008)</i> <b>Yes</b> - drilling may be required for use in other vehicles	<i>Upper Pole</i> ordered separately <i>(Lower Tube</i> included with base)	<b>Yes</b> - overall 11.55" to 16.55" (depending on <i>Upper Tube</i> selected)	6.8 lbs	11.3"	17.8"	5.5"

#### Features

- Heavy gauge steel construction for long-term durability
- Black powdercoat finish for maximum corrosion resistance
- Won't interfere with levers or factory-installed consoles located on transmission hump
- Won't interfere with passenger leg space
- Adapter brackets that don't require drilling are available for other select vehicles. Contact Gamber-Johnson for options/availability.
- For extra stability a *Support Brace* (Item No. LAC-02) is recommended

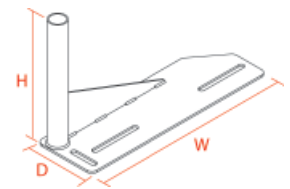

**Item No. DS-59**

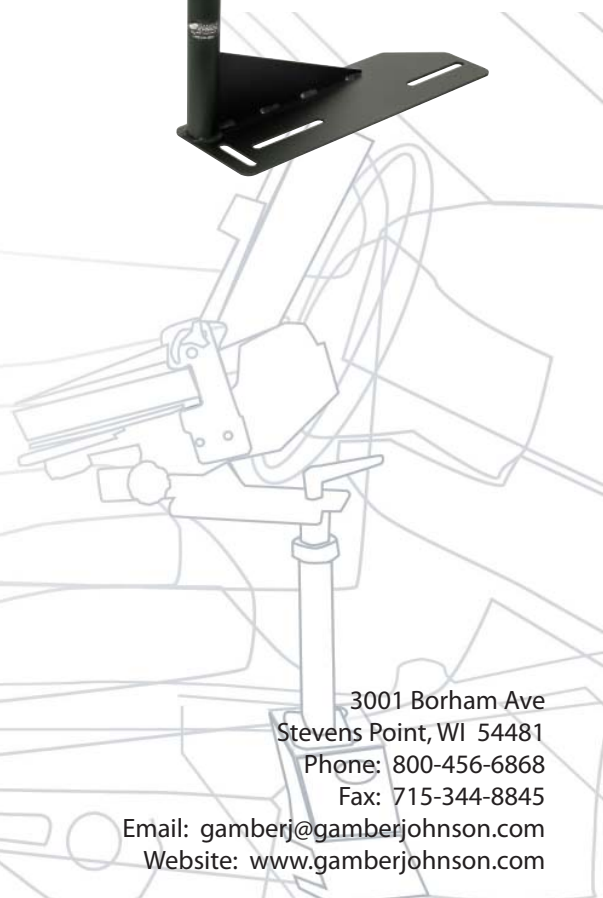

3001 Borham Ave  
Stevens Point, WI 54481  
Phone: 800-456-6868  
Fax: 715-344-8845

Email: [gamberj@gamberjohnson.com](mailto:gamberj@gamberjohnson.com)  
Website: [www.gamberjohnson.com](http://www.gamberjohnson.com)