

Intellian i6/i6P Serial Number



This serial number will be required for all troubleshooting or service calls made regarding this product.

Notice

All Right Reserved

Intellian i6/i6P[®] and Intellian[®] are the registered trademarks of Intellian Technologies, Inc., and should not be appropriated without permission by Intellian Technologies, Inc., and the information contained in this manual is the property of Intellian Technologies, Inc. Any and all parts of this manual shall not be reproduced and distributed in any form without prior written consent by Intellian Technologies, Inc. The information contained in this manual shall be subject to change at any time without notice due to the functional upgrades of the product.

Copyright© Intellian Technologies, Inc.

Doc. No. I6/I6P-DC V100

CONTENTS

.....	3
TO INTELLIAN I6/I6P(PREMIUM)	3
OF INTELLIAN I6/	4
SYSTEM	5
.....	6
.....	6
REQUIRED FOR	9
THE	10
THE	15
THE SYSTEM TO A	20
SATELLITE	21
THE LNB SKEW ANGLE (LINEAR POLARIZATION ONLY)	22
.....	24
.....	24
USING THE	25
SOFT	25
.....	25
UP	30
USING PC CONTROLLER	52
.....	52
INITIALING AND SERIAL PORT	53
MENU – USING DEFAULT DUAL-SAT	54
SATELLITE	55
MENU- USING ADVANCED TRI-SAT	57
SATELLITE	58
.....	61
.....	66
FOR	68
.....	69
: TECHNICAL	70

INTRODUCTION

Introduction to Intellian i6/i6P(Premium)

Intellian i6/i6P is a digital satellite antenna system designed specifically for all types of vessels (Anchored or transit) to automatically identify, track and capture satellite signals from the Digital Video Broadcasting (DVB: the international standard for digital TV transmissions) compatible satellites.

Specifically, Intellian i6/i6P has Wide Range Search (WRS) algorithm, which minimizes the search time during initialization, and Dynamic Beam Tilting (DBT) technology, which dynamically shapes the antenna beam to utilize stabilization. Once the satellite is acquired, the antenna DBT continuously measures the heading, pitch, and roll of the vessel by obtaining the satellite signal level around the antenna point, and transmits commands to the antenna motors to keep the antenna pointed at the satellite at all times. This active stabilization is enhanced by a conical scan tracking function to detect and lock onto the strongest signal, resulting in the clearest reception possible.

The i6/i6P has a built-in GPS system which enhances the speed of satellite signals acquisitions. In addition, the i6P provides the embedded auto skew angle control system to maintain the optimal signal strength and increase the quality of satellite receptions in weak satellite single coverage area.

Features of Intellian i6/i6P

Enjoy satellite broadcasts at sea

Intellian i6/i6P is the most modern antenna system that enables you to receive a high quality broadcasting signal at sea, where the atmospheric and environmental condition are very harsh.

Fully automatic control system

Fully automatic control system allows you to simply turn the power switch on, and have crystal clear, high quality satellite television in motion or at anchor.

High quality antenna

High tech parabolic antenna technology has been adopted for this antenna system, which is optimal for marine conditions. This enables you to receive the optimal signal level even when it is raining or snowing.

Fast and efficient search for the satellite

The WRS (Wide Range Search) algorithm allows for the antenna system to search the satellite within the shortest amount of time and to detect the satellite signal under any position and with any directional movement of the ship.

Easy installation and outstanding reliability

Intellian i6/i6P uses only one RF cable for installation. This makes installation easy. Power, RF and Data signals transfer from the antenna the ACU through this single cable. In addition, Intellian i6/i6P provides highly reliable system through the implementation of a modularized design, and the usage of strictly proven components.

Built-in GPS

Intellian i6/i6P has imbedded GPS, which allows for the system to upload the GPS data automatically into the system for an even faster and stable system.

Built-in automatic skew angle control system

The automatic skew control system allows Intellian i6P to maintain the optimal skew angle at all times and ensure maximum level of satellite signal level.

Basic System Configuration

For your satellite TV system to work properly, the system will have to be connected with all of the provided components properly, as shown in the figure below (Refer to next chapter 'Installation' in this manual for more detailed connection instructions). Separate purchase of a satellite receiver and a TV is required.

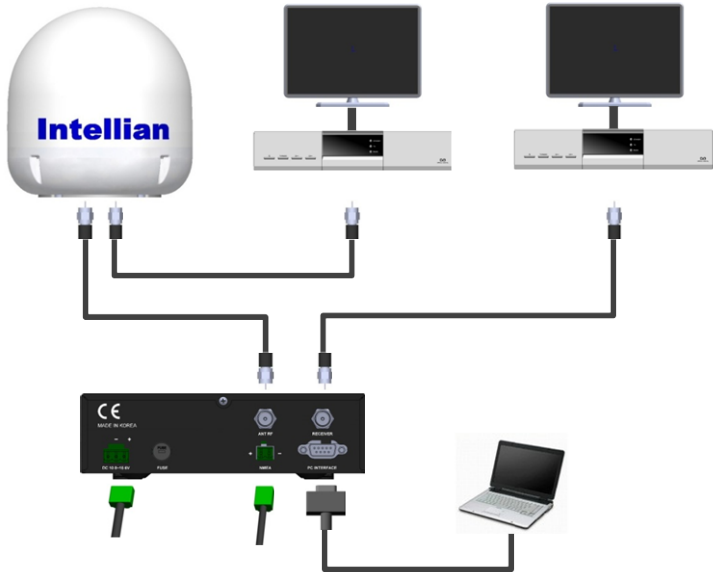

Installation

The components of the Intellian i6/i6P have been designed to be modular so that it is suitable for simple installation on all types of vessels.

System Components

Antenna Unit

The antenna of Intellian i6/i6P is composed with the following components for the optimum search and reception of the satellite signal.

- Mechanical Unit – manipulates the antenna to receive the optimal satellite signal regardless of the movement of the vessel.
- Control Unit – controls mechanical operation of the antenna.
- RF Unit – transmits the optimum satellite signal to the receiver.
- Radome – protects the antenna from the severe marine environment.



Antenna Control Unit (ACU)

The Antenna Control Unit (ACU) provides the power to the antenna and controls the various settings of the antenna. Additionally, VFD (Vacuum Fluorescent Display) allows for you to operate the ACU in the dark.

The functions of the ACU are as follows:

- Provide power for the antenna unit
- Monitor the antenna status
- Change the target satellite
- Set up the user environment
- Set the current GPS information
- Set satellite information
- Move antenna manually
- Perform self-diagnosis of the antenna
- Set up the interface with a PC



Installation Kit

Contain the items required for securing the antenna unit and ACU to your boat.

Antenna					ACU	
						
Hex. Bolt 5EA	Hex Head Wrench Bolt 5EA	Flat Washer 5EA	Spring Washer 5EA	Hex. Nut 5EA	Tapping Screw (Φ4x16L) 5EA	Machine Screw (Φ3x8L) 5EA

Other Components

No	Components	Size	Q'ty
1	ACU Bracket	-	2EA
2	RG6 (Antenna – ACU RF Cable)	15m	1EA
3	RG6 (ACU – IRD Cable)	3m	1EA
4	Power Cable	10m	1EA
5	PC Serial Cable	1.8m	1EA
6	NMEA Connector	AK950-2	1EA
7	Power Connector	AK950-3	1EA
8	Hex Bolt	M8x50L	5EA
	Tapping Screw	ø4x16L	5EA
	Tapping Screw	ø3x8L	5EA
	Flat Washer	M8	5EA
	Spring Washer	M8	5EA
9	Install CD	-	1 EA
10	Manual	-	1 EA
11	Mounting Template	-	1 EA
12	Quick Installation Guide	-	1EA

Tools Required for Installation



Power Drill



11mm Spanner



Cross-Head
Screwdriver



13mm Spanner



Φ10mm Drill



Pencil



Φ80mm
Hole Saw



5mm
Allen key

Planning the installation

Selection of Installation Site

Install the antenna in accordance with the following procedures to insure maximum performance of the antenna.

The ideal antenna site has a clear view of the horizon/satellite all around. Please be sure there are no obstacles within 15 degrees above the antenna. Any obstacles located above a 15 degree elevation can prevent the antenna from tracking the satellite signal (Refer to the drawing).

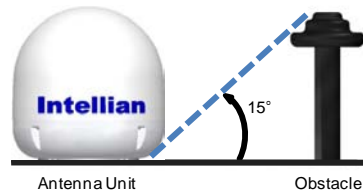

Keep the antenna out of line with nearby radars, as their energy levels may overload the antenna front-end circuits. If necessary, position the antenna unit so it is at least four feet (1.2 meters) above or below the level of the radar.

Make sure that the mounting surface is rigid, so that it will not flex when the vessel vibrates. If necessary, add a stiffening member to the mounting site to strengthen it.

The movement of the antenna can be minimized by installing it at the center of the ship. For optimal performance of the antenna, it is not recommended to install at any corner of the ship, where the movement of the ship is the greatest.

Install the bottom of the antenna parallel to the surface of the sea and fix tightly to the structure of the ship.

When setting the antenna down, be careful not to have the RF connector. Striking the connector on the bottom directly will damage the connector and make connection impossible.

Cables

Before installing the system cables, you need to take the following points into consideration.

- All cables need to be well clamped and protected from physical damage and exposure to heat and humidity.
- Cable with an acute bend is not allowed.
- Where a cable passes through an exposed bulkhead or deckhead, a watertight gland or swan neck tube should be used.

Power requirements

You need to follow the power requirements to avoid damage the system.

Intellian i6/i6P has been designed to work on a boat's power supply rated at 12VDC (acceptable range: 10.8~15.6 V DC).

If your IRD(s) and television(s) require a 110V/240V AC power supply, you will need to install a suitable DC to AC converter to operate the unit(s) from your boat's DC power supply.

Extending the cables

The cables that have been supplied with your Intellian system should be of adequate length to complete the installation on most boats.

Power Cable

This cable supplied at a length of 10m.

RF Cable

This cable is supplied at a length of 15m. If a longer length is required you should replace this cable with an extended RF cable supplied by Intellian Technologies.



WARNING

Exceeding the indicted cable lengths will result in reduced performance of your system.

Installation and Mounting of antenna

The method of installation and mounting of antenna may vary with vessel design but the following procedures are applicable in most situations, and will result in a secure and effective installation.

Confirmation of size prior to installation

- Confirm the height and diameter of the bottom surface of the antenna before installing it.
- The space must be sufficient for installing the antenna unit considering the height and diameter of the antenna.
- The height and the diameter of the bottom surface of the antenna are as shown in the following drawing. If possible, install the antenna using a power tower.

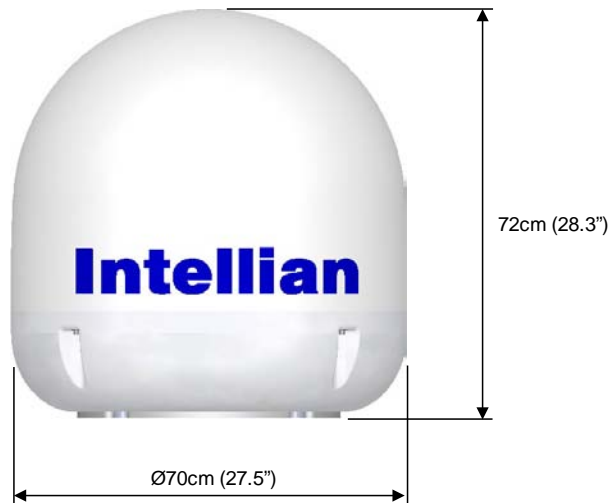

WARNING

Before installing the antenna you have to remove the radome and remove the shipping foam from the antenna interior. Replace the radome before installation. **The system functions will be abnormal if the radome is off.**

Mark of the antenna mounting position

Referring to the mounting template, mark where antenna is to be mounted on board the ship (it must be a flat surface) or on a separate power tower by drawing a square of 30.37 cm (12").

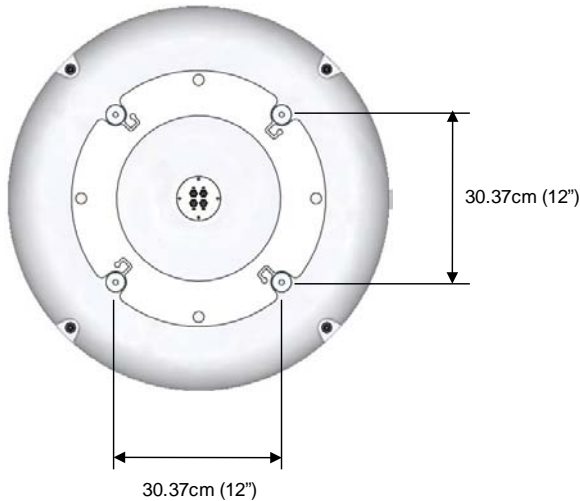

WARNING

If a power tower is not used to mount the antenna, separate cable shock and waterproofing measures must be taken to protect the RF connector from being exposed to the sea water and external shocks. An exposed cable may cause electric shock and cause serious damage to the equipment.

Securing hole for bolts and cable way

Make 4 bolt holes of 10mm diameter, one at each corner of a rectangle drawn as above, and make a circular hole of 80mm diameter at the center of the rectangle, through which the cable will run.

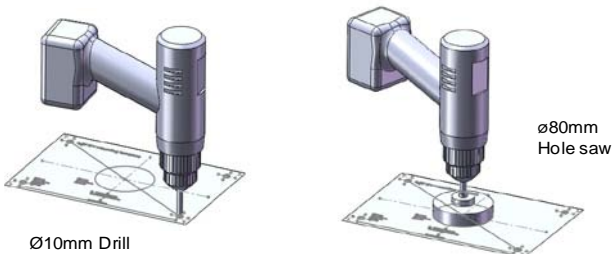

Connection of the RF cable

Remove the rubber protector from RF connector. Connect the RF cable to the RF connector under the base plate through the access hole using a 11mm spanner. Be careful not to tighten it too much, as you may damage the connector.

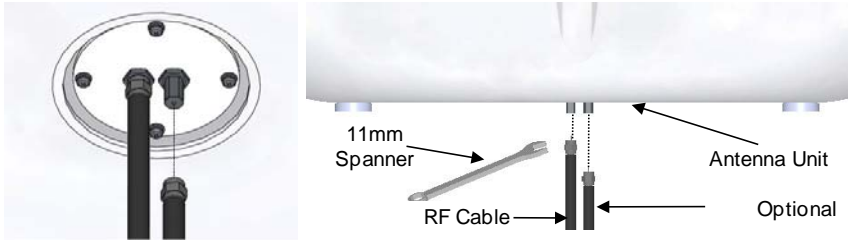

WARNING

Do not use excessive force when using the spanner, this will damage the threads. Be careful that the connectors do not contact the mounting surface of the antenna, this may cause a critical malfunction and serious damage to the equipment.

Mounting the antenna

Attach the antenna by using the hex head bolts (M8X50L), M8 spring washers, and M8 flat washers supplied.



Installing the ACU

ACU dimensions

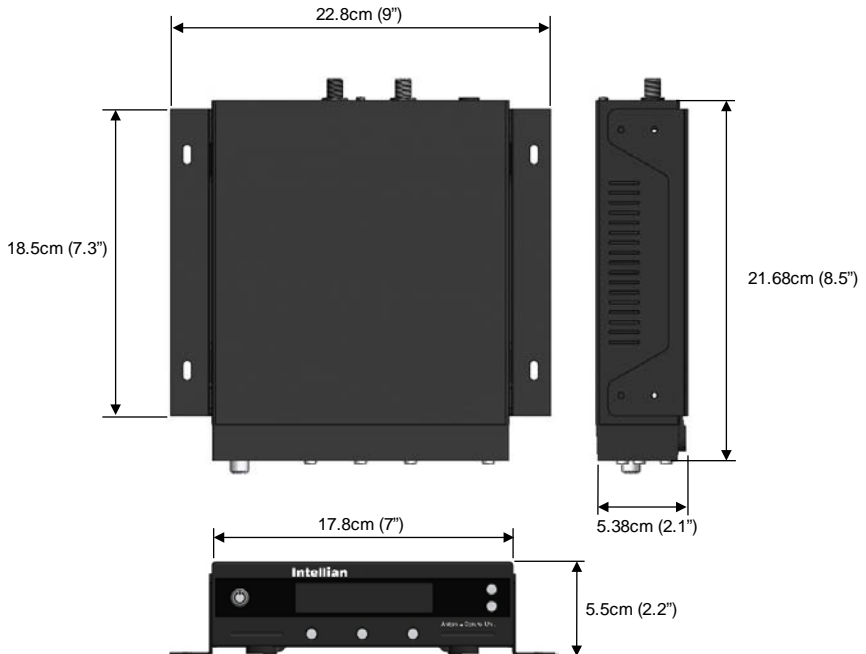

Selection of Installation Site

The ACU should be installed below deck, in a location that is :

- Dry, cool, and ventilated.
- Easy accessible from your main TV viewing area.

To Install the ACU

1. The ACU should be installed using the two supplied mounting brackets which allow for a top or bottom mounting configuration.
2. Using the self tapping screws supplied, attach the mounting brackets to the sides of the ACU.
3. Place the ACU in the location where it is going to be installed.
4. Connect the cables to the rear of the ACU.
5. Using a pencil to mark the 4 hole positions (2 each side), and use the appropriate drill bit to drill them.

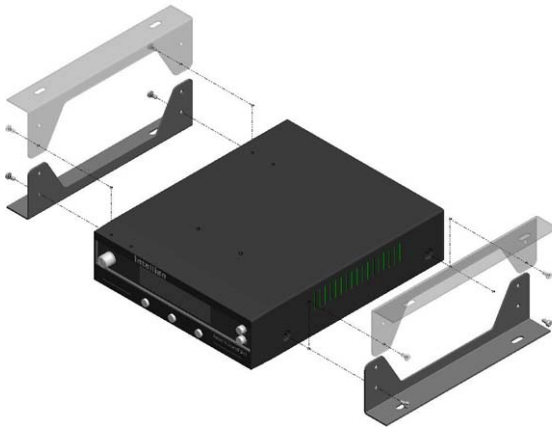

Connecting the System Cables

After installation and fixation of the antenna, connect the ACU to the antenna. Refer the drawing below to connect cables.

SINGLE IRD Connection

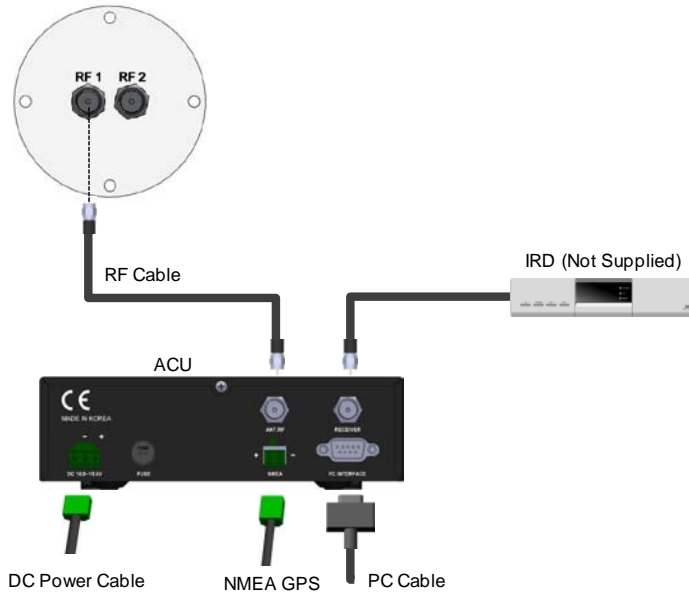

- Connect the RF Cable (15m) from the RF 1 connector on the antenna to the ANT. RF1 connector on the rear of ACU.
- Connect the ACU-IRD Cable (3m) from the RECEIVER connector on the rear of the ACU to RF on the IRD.
- Connect the power cable (10m) from DC power connector on the rear of ACU to a power source at 12V DC .
- Press the POWER ON switch in front of the ACU to start the operation of the antenna system automatically.

Twin IRDs Connection

You can connect two IRDs for your antenna as shown in the following diagram. However, only one of the IRDs can be configured as a two satellite receiver.

The other IRD needs to be configured as a one satellite receiver. The two satellite receiver determines which satellite is tracked, while the other receiver can watch any channel which is available from the tracked satellite.

As in the single IRD option the RF cables from the antenna base plate should be connected to 'LNB', 'ANT', or 'Satellite In' on the rear panel of IRD.

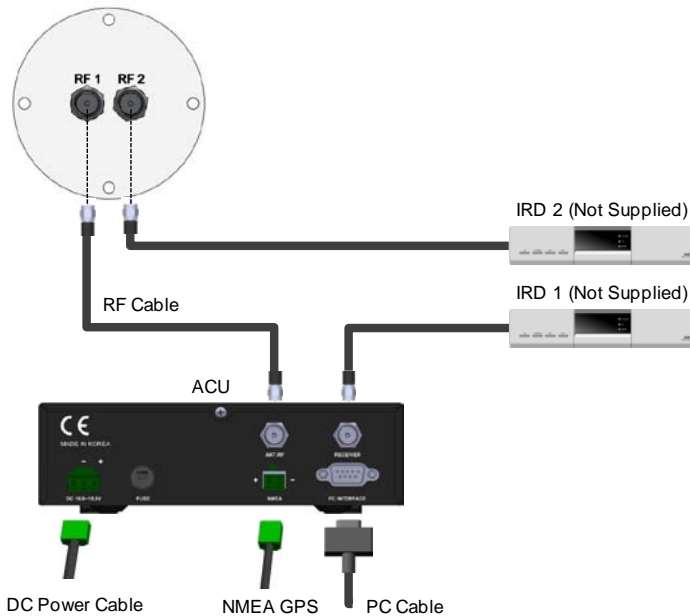

Multiple IRDs Connection

In order to connect multiple IRDs to the antenna, you will need to purchase a suitable active multiswitch. The multiswitch has to be installed between the antenna unit and the IRDs as shown in the following diagram.

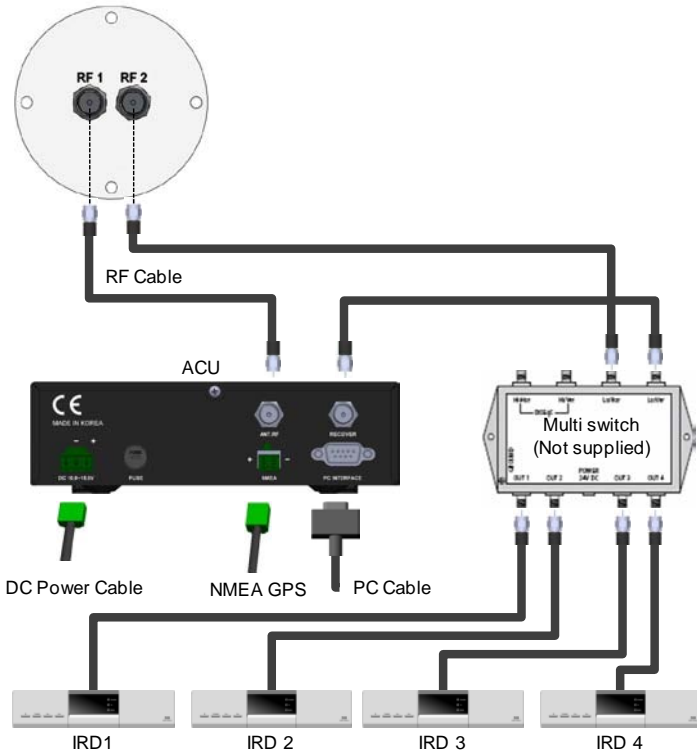

※ IRD 1~4 : Not supplied

Connecting the system to a GPS

For improved satellite tracking, you can connect your satellite TV system directly to your boat's NMEA 0183 GPS system. To do this you will need lengths of cable suitable for connecting to your GPS system and the green 2-way ACU GPS connector supplied with your Intellian i6/i6P Satellite TV System.

To connect the system to a GPS

1. Strip back the insulation of each cable and connect a cable to each terminal of the 2-way connector.
2. Tighten the locking screws.
3. Connect the cable from the **+ve** (positive) terminal of the ACU GPS connector to the NMEA **OUT** wire of the boat's GPS system.
4. Connect the cable from the **-ve** (negative) terminal of the ACU GPS connector to the **ground wire** of the boat's GPS system.
5. Refit the ACU GPS connector to the rear of the ACU.

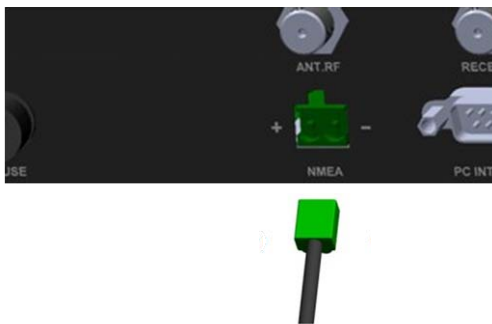

Target Satellite Setting

You can select the target satellite to receive satellite signal from. If the target satellite is not on the list you will have to register the target satellite.

GPS Setting

You can input the GPS information through the ACU or the PC Program. To setting the GPS information, the antenna system has to be in 'SET UP mode'. For detailed instructions, please refer to page 38; 'Setting the GPS', and page 59; 'Set Antenna GPS and find Antenna Angle'.

Satellite registration

You can register the target satellite through the ACU or the PC program. To register the target satellite, the antenna system has to be in 'SET UP mode' and the required information is, Satellite name, Satellite Longitude, Method of Satellite Identification, Frequency of each of the band, Symbol Rate, Network ID, Power Change method. For detailed instructions, please refer to page 31; 'Edit Satellite Information', page 53; 'Set Satellite Information', and page 60; 'Set Tracking Information of Satellite'.

Satellite Pair Selection

You can select the Satellite Pair from the list through the ACU or the PC program. You can easily select the target satellite from the satellite pair. For detailed instructions please refer to page 29; 'Setting the Satellite pair', page 53; 'Set Satellite Information'.

Target Satellite Selection

Choose the target satellite from the Satellite Pair. When selecting through the ACU, you have to press the left button to select the target satellite while the antenna system is in either 'Searching Mode' or 'Tracking Mode'. When using the PC program you can select either satellite 'A' or satellite 'B' from 'Tracking Satellite' at anytime.

Adjusting the LNB Skew Angle (Linear polarization only)

LNB Skew Angle

The LNB skew angle only needs to be adjusted when the target satellite uses linear polarization. In order to receive the maximized satellite signal level, the LNB skew angle must be adjusted according to the calculation of current GPS location and target satellite.

It only needs to be adjusted when changing from satellite to another, or when the boat has traveled a significant geographic distance. It should NOT need to be readjusted if the boat stays in the same location and is operating on the same satellite.

Skew Angle Adjustment for i6

Polarization of your Intellian i6 antenna must be accomplished manually by the following steps.

1. Remove the upper part of radome after switching power OFF.
2. Loosen the 4 bolts that connect the LNB and feed horn.
3. Turn the LNB and place it at the angle indicated on the back of the feed horn.
4. Tighten the 4 bolts.

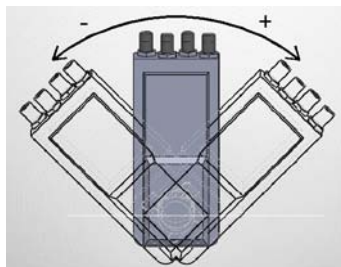
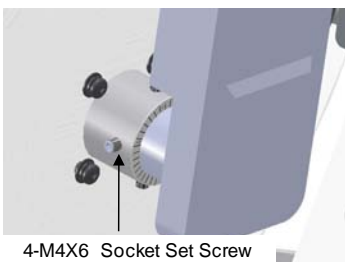

Auto Skew Angle Adjustment for i6P

Intellian i6P with an embedded auto skew angle control system. Therefore, manual adjustment of skew angle by user is not required. The skew angle is continuously adjusted automatically through the calculation of the optimum skew angle by using the information of the targeted satellite and the output value from the GPS sensor. Together with such location information of the ship as ship's longitudinal and latitudinal position change from movement the skew angle will be adjusted accordingly. The skew angle of LNB is shown from the ACU and GUI Program.

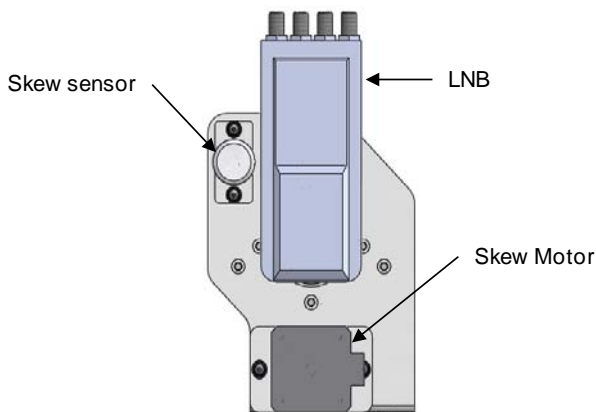

Operation Instruction

Introduction

This section of the handbook describes how to set up your Satellite TV System after installation using the ACU or PC controller program and includes the following functions:

- System start up.
- Changing the default satellite.
- Monitoring the antenna status.
- Setting sleep mode.
- Entering setup mode.
- Setting the satellite pair.
- Editing satellite information.
- Setting the antenna parameter.
- Setting the LNB local frequency.
- Setting GPS.
- Setting the DiSEqC method.
- Display versions.
- Display power status.
- Setting antenna go position.
- Setting antenna move step.
- Setting remote control.
- Setting the factory default parameters.
- Performing diagnostic tests.



WARNING

Note: Many of the above functions will only be required only after initial installation of your system. **Refer to the Quick Installation Guide** before operating the system.

Operation Using the ACU

ACU Soft Keys

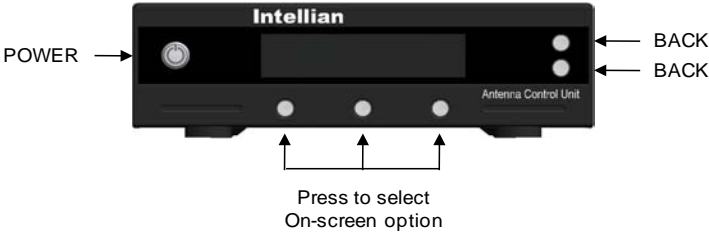

Normal Mode

Start Up

With the system installed and power applied, the ACU screen will show the following sequence:



1. Communication is being established between the antenna and the ACU. The ACU initialized.



2. The antenna is initialized.

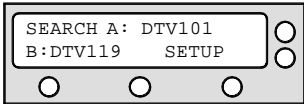

3. The antenna is searching for Satellite A.

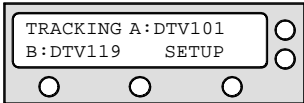

4. The antenna has located the satellite and is now tracking.

Change of Target Satellite

Your antenna is programmed with two candidates of target satellites as default Dual-sat mode. Use advanced Tri-sat mode for targeting three satellites. To change the target satellite, press LEFT soft key. The target satellite is changed and is automatically tracked by the antenna.

Default Dual-sat Mode

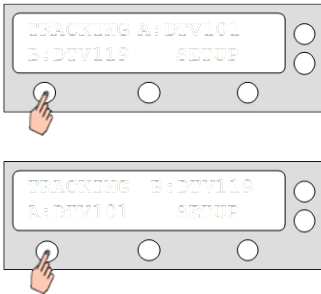

Advanced Tri-sat Mode



Monitoring the current status of the antenna

While POWER ON to Intellian i6/i6P, ACU displays the status of the antenna. The various ACU displays may be shown according to the current status of the antenna.

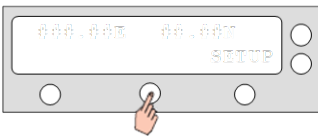
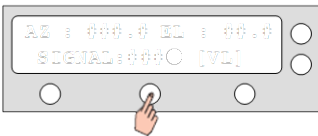
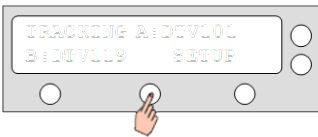

Sleep Mode

If the antenna lost the tracking satellite in sleep mode, sleep mode is cancelled.



Set Up Mode

Begin Set-Up Mode

To enter the Set-up Mode simply follow the instructions below:

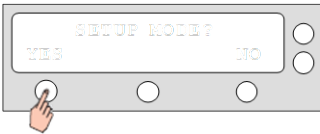

Setting the Satellite Pair

You can change the satellite pair if you decide to receive satellite television service from a different service provider.

Example1. Changing the target satellite without using DiSEqC:

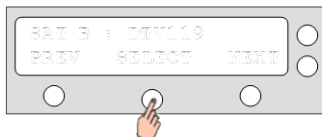
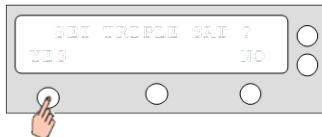
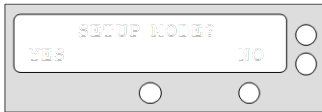

Example2. Changing the target satellite using DiSEqC:

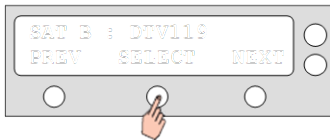
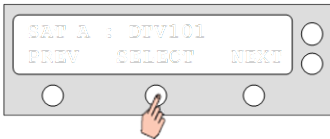
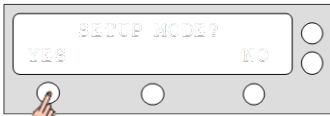

Edit Satellite information

It is possible to modify the existing satellite information and input new satellite information into the ACU as well. It is not recommended for a novice satellite service user to use this mode.

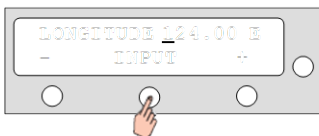
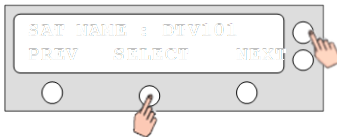

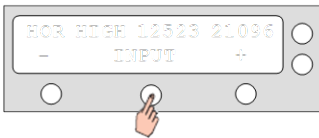
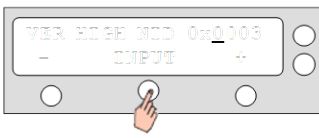
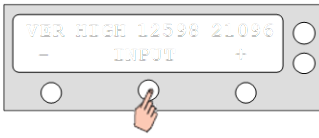
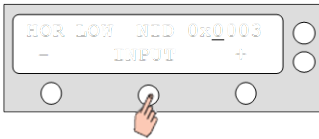
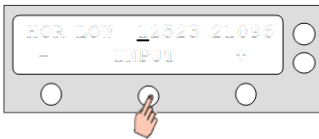
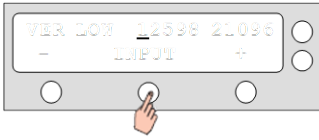



Setting the Antenna Parameters

It is not recommended for a novice satellite service user to use this mode. Consult Intellian for changing antenna parameters.

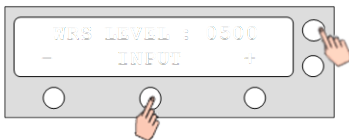
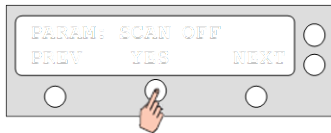
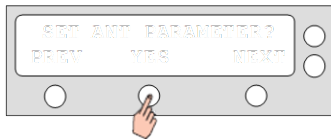

1) Parameter Setting method

SCAN OFFSET – The actual angle between the marked point on the sub-reflector and the datum.

TRACK SCALE – To control the tracking speed while antenna is tracking the satellite. High Track Scale value resulting in high tracking speed.

DETECT LEVEL – The basic single detection level.

TRACKING LEVEL – The basic signal tracking level

ELADJUST – The mechanical tolerance compensation of elevation limit.

WRS LEVEL – The basic WRS detection level.

POWER THRESHOLD – The value to identify Vertical/Horizontal or RHCP/LHCP.

DISEQC LEVEL – The value to identify 22KHz tone.

OFFSET RH-LH – The difference value between RHCP/LHCP and SCAN OFFSET.

USE WRS – To apply WRS while antenna is searching for satellite.

OFFSET DIFFERENCE – To apply Offset Difference.

Setting the LNB local frequency

It is possible to select a local frequency from ACU. It is not recommended for a novice satellite service user to use this mode.

CASE 1. Single band LNB is used.

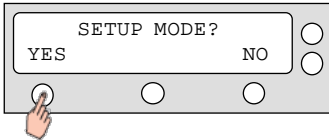

1. Press YES to enter setup mode.

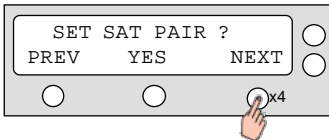

2. Press NEXT four times to enter set local frequency mode.

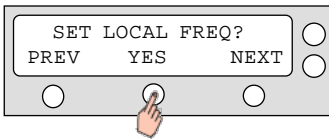

3. Press YES to set local frequency.

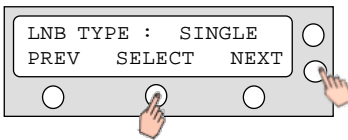

4. Select the LNB Type ¹⁾ – SINGLE.
 PREV – Shows previous LNB type.
 SELECT – Set the displayed LNB type.
 NEXT – Shows next LNB type.
 Press ENTER to move to next screen.

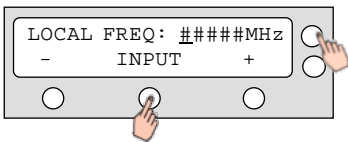

5. Input the local frequency of LNB.
 +increases the value. – decreases the value.
 Change the underscored digit using the +/- buttons. Press INPUT to accept the value and move to next digit. Press BACK to move to previous digit. Press ENTER to move to next screen.



6. Press YES to accept the data.
 Press NO to cancel and return to main setup mode.

CASE 2. Universal LNB is used. (Low band local frequency-9750 MHz/ High band local frequency 10600 MHz)



Setting the GPS

It is possible to set up and modify the GPS information, which enhances the antenna functionality.

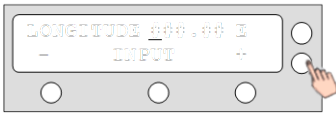
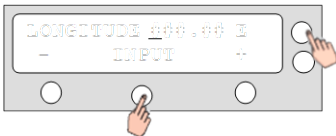
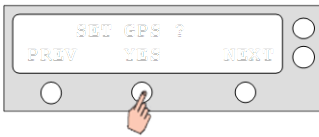
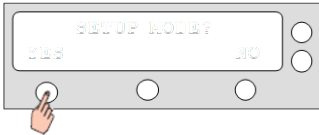

Setting the DiSEqC Method

DiSEqC selection can be made from ACU. It is not recommended for a novice satellite service user this mode.

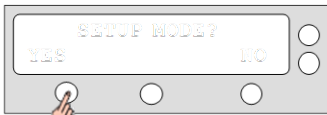

Display Versions

This sequence enables you to see what version of antenna and ACU software version are installed on your system.

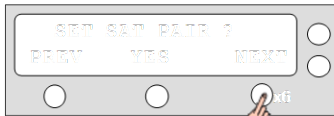
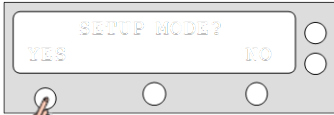

Display Power

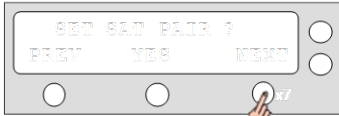
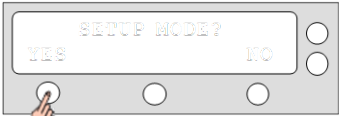

Setting Antenna Go Position

The antenna can be controlled manually by using ACU.

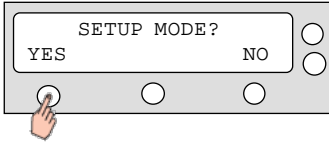

1. Press YES to enter setup mode.

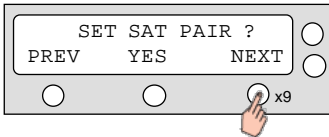

2. Press NEXT nine times to enter the antenna go position mode.

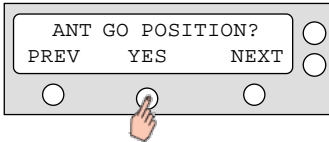

3. Press YES to go position.

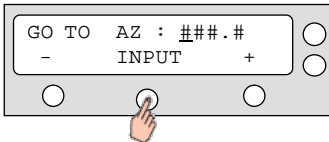

4. Input position value for azimuth (AZ) axis.
+ increases the value. – decreases the value.
Change the underscored digit using the +/- buttons.
Press INPUT to accept the value and move to next digit. Press BACK to move to previous digit.
Press ENTER to move to next screen.

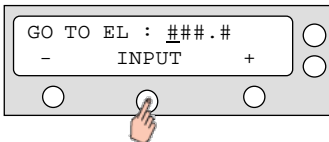

5. Input position value for elevation (EL) axis.
+ increases the value. – decreases the value.
Change the underscored digit using the +/- buttons.
Press INPUT to accept the value and move to next digit. Press BACK to move to previous digit.
Press ENTER to move to next screen.

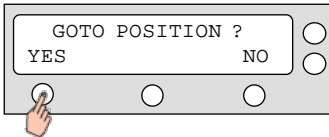

6. Press YES to move the antenna to input position.
Press NO to return to the Antenna Go Position mode.

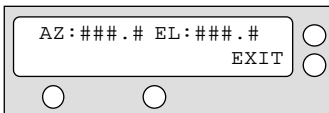

7. Press EXIT to return to main setup mode.

Setting Antenna Move Step

The antenna may be moved by 1° step manually by using ACU.

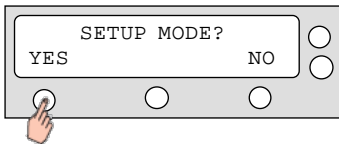

1. Press YES to enter setup mode.

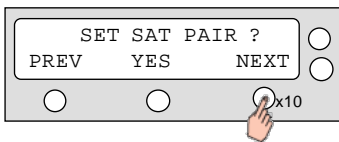

2. Press NEXT ten times to enter the antenna move step mode.

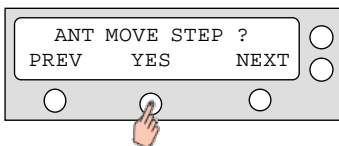

3. Press YES to move step.

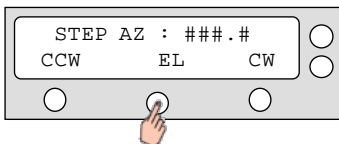

4. Move the antenna in the azimuth (AZ) axis.
 CW – Move the antenna clockwise.
 CCW – Move the antenna counter-clockwise.
 EL – Go to elevation control screen.

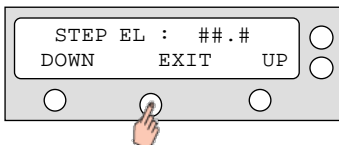

5. Move the antenna in the elevation (EL) axis.
 UP – Move the antenna up.
 DOWN – Move the antenna down.
 EXIT – Return to Antenna Move Step mode.

Setting Remote Control

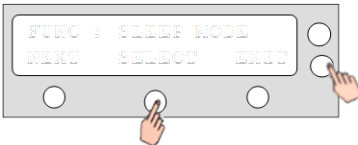
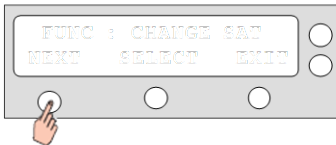
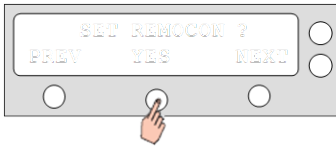
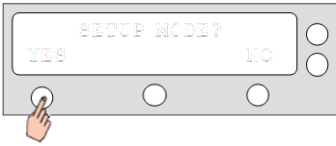



7. If failed to press same key twice, TRY AGAIN will be displayed.

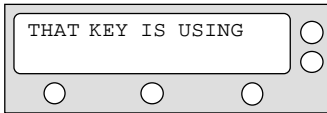

8. If failed to register a free key, KEY IS USING will be displayed.



9. REMOTE KEY REGISTERED will be displayed if key has been properly registered.

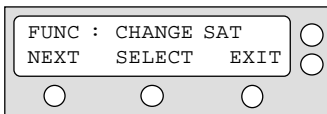

10. Press NEXT to shows next function.
Press EXIT to return to main setup mode.

- 1) Function
 CHANGE SAT
 SLEEP MODE
 CLEAR REGISTERED KEY

Change the target satellite.
 Enter sleep mode.
 Clear registered key.

Executing Antenna Diagnosis

It is possible to see the antenna status by reviewing the result of diagnosis of the antenna. Refer to the following codes, to understand the diagnosis results.

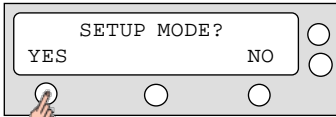

1. Press YES to enter setup mode.

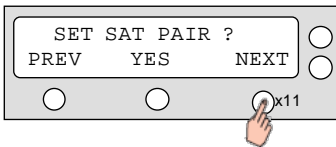

2. Press NEXT eleven times to enter the antenna diagnosis mode.

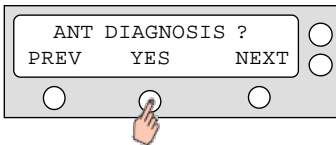

3. Press YES to diagnosis antenna.

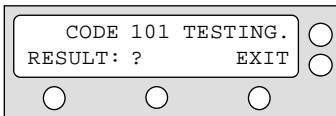

4. CODE 101 is being tested.
Press EXIT to return to main setup mode.

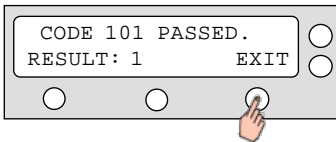

5. CODE¹⁾ 101 is pass.
Press EXIT to return to main setup mode.

CODE 101 : Communication between antenna and antenna control unit is tested.
If failed, check the power and data cable.

CODE 102 : AZ CW limit is tested.
If failed, check the limit sensors, motor ,and belt for AZ axis.

CODE 103 : AZ CCW limit is tested.
If failed, check the limit sensors, motor ,and belt for AZ axis.

CODE 104 : EL axis is tested.
If failed, check the limit sensors, motor ,and belt for EL axis.

CODE 105 : Sub-reflector is tested.
If failed, check the sub-reflector.

CODE 106 : LNB is tested.
If failed, check the LNB and control board.

CODE 107: Skew System tested.
If failed, check the control board, skew motor ,and skew sensor

CODE 108 : Antenna Input Power tested.
If failed, check the RF cable.

CODE 109 : ACU Power tested.
If failed, check the ACU power cable and Input DC power.

CODE 110 : IRD Power tested.
If failed, check the ACU to IRD cable and IRD power.

RESULT STATUS : ● is pass. Number is fail(● ● 3 ● ● ● ● 8 ● ●). And ? Is Testing.

Setting Region

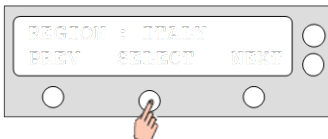
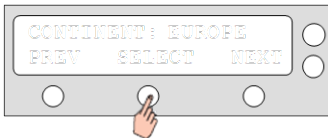
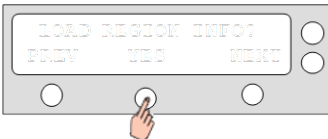
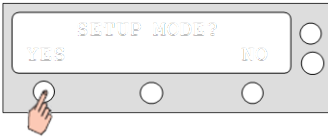

1) CONTINENT

N. AMERICAN, S.AMERICAN, EUROPE, ASIA..

2) REGION

New York, Miami, UK, JAPAN..

Setting the factory default parameters

Initialize all of the antenna information to the factory set up.



OPERATION USING PC Controller Program

Introduction

GUI Software of Intellian i6/i6P has been coded for the user to easily set up the antenna by using the user's personal computer. Using the GUI program enables the user to easily monitor and modify the information of antenna, satellite and GPS. Additionally, the detail diagnostic method of the antenna is provided by the GUI program.

To start this GUI program,

1. Connect one end of PC serial cable to the serial port on the computer.
2. Connect the other end of the PC serial cable to the "PC Interface" on the rear of ACU.
3. Execute GUI program by inserting the CD-ROM supplied into the CD-ROM drive of the computer.
4. After turning on the power of the ACU, if the blue status circle does not change to 'Search' or 'Tracking' from 'Initialize', then you have to change the "PC Interface" terminal of ACU for PC program use rather than GPS use.

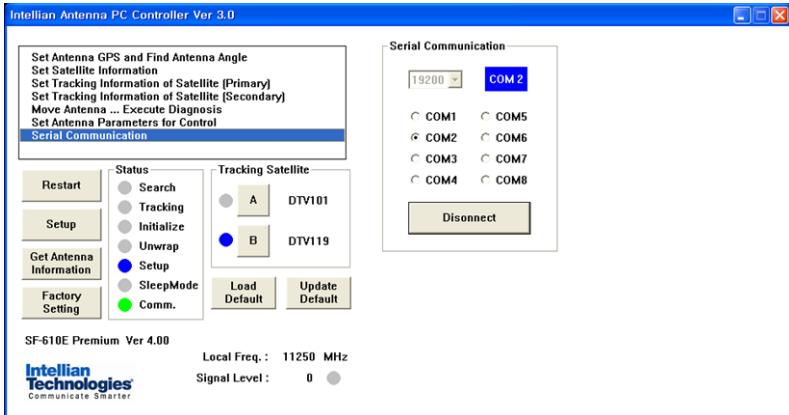

Program Initialing and Serial Port Setup

The communication between the ACU and antenna must be established as the first step in order to start setting your antenna.

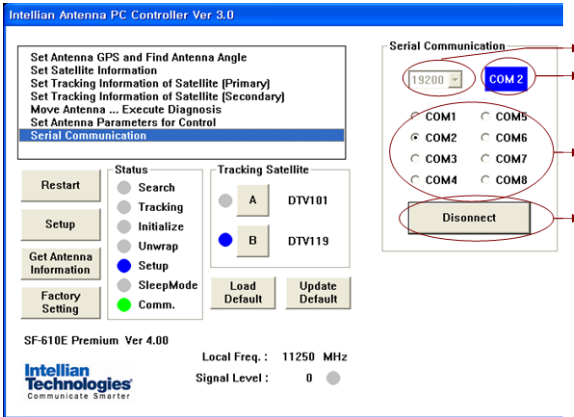

Command Button

- Baud Rate Setting – To display communication speed.
- Connection Status Display – To display communication port between ACU and PC.
- Serial Port Setting – To select serial port to be used.
- Connect/ Disconnect – To establish communication between PC and ACU.

Main Menu – Using Default Dual-sat Mode

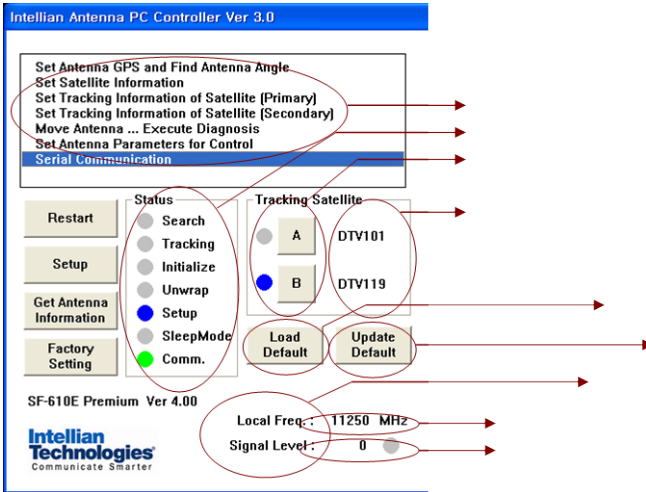

Antenna Status Monitoring

- Search – Antenna is searching for the selected satellite.
- Tracking – Antenna is tracking the selected satellite.
- Initialize – Antenna or the ACU is initializing.
- Unwrap – Antenna is unwrapping the wire.
- Setup – Antenna is in setup mode.
- Comm. – Antenna is possible communication.

Definition of Program Command Buttons

- Restart – To exit setup mode and restart antenna again.
- Setup – To enter the setup mode.
- Get Antenna Information – To indicate the information on display after receiving it input to the antenna.
- Factory Setting – To initialize all antenna information to the default as same as ex-factory status.
- Load Default – To show the up-to-date information input to PC program on display.
- Update Default – To update the antenna information by the up-to-date input to PC program.

Set Satellite Information

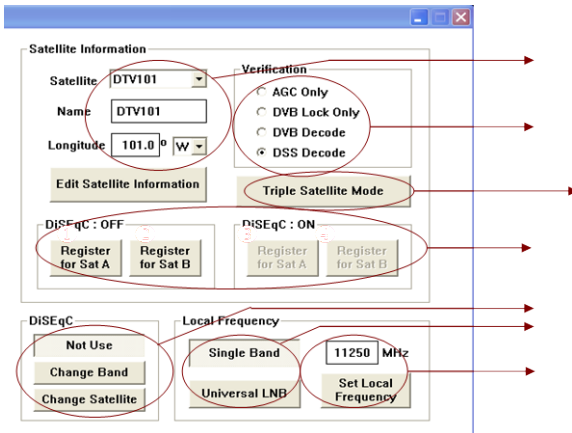

- **Satellite Information**

The name, longitude and confirmation method of the satellite is displayed when a satellite is selected in the list box. Push “Edit Satellite Information” button to update the information on modifying the value.

- **DiSEqC**

When the operation method of DiSEqC is selected to “Change Band”, DiSEqC may be used for updating the local frequency and to “Change Satellite”, for updating the target satellite.

- **Registration of target satellite**

In case that the DiSEqC is selected to “Not Use” or “Change Band”, only ❶ “Register for Sat A” and ❷ “Register for Sat B” may be registered. Pushing ❶ or ❷ button after selecting the satellite in the list box makes it possible to register A or B. In case that DiSEqC is selected to “Change Satellite”, ❸ “Register for Sat A” and ❹ “Register for Sat B” are activated and the target satellite when DiSEqC is available may be registered by pushing ❸ and ❹ buttons.

- **Local Frequency**

In case that DiSEqC is selected to “Change Band”, be sure to push the “Universal LNB” button. In case that the DiSEqC is selected to “Not Use” or “Change Satellite”, be sure to push “Single Band” button and key in into the Local Frequency, and then push “Set Local Frequency” button.

Command Button

- Edit Satellite Information – To modify the satellite information.
- Register for Sat A – To register a satellite to satellite A.
- Register for Sat B – To register a satellite to satellite B.
- Not Use – Do not use DiSEqC.
- Change Band – To use DiSEqC to change band.
- Change Satellite – To use DiSEqC to change the satellite.
- Single Band – Antenna in use of Single LNB.
- Universal Band – Antenna in use of universal LNB.
- Set Local Frequency – To select local frequency of LNB.

Main Menu- Using Advanced Tri-sat Mode

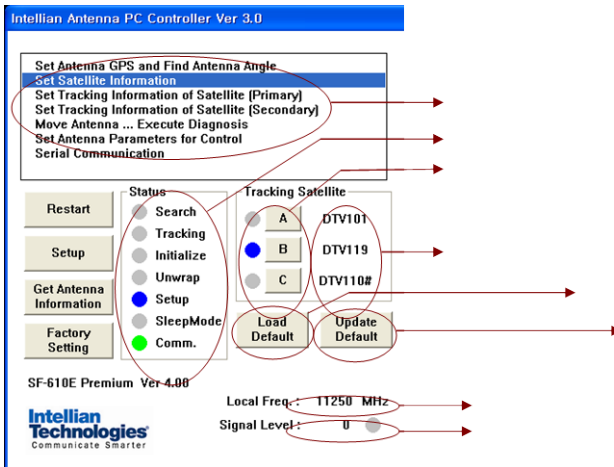

Antenna Status Monitoring

- Search – Antenna is searching for the selected satellite.
- Tracking – Antenna is tracking the selected satellite.
- Initialize – Antenna or the ACU is initializing.
- Unwrap – Antenna is unwrapping the wire.
- Setup – Antenna is in setup mode.
- Comm. – Antenna is possible communication.

Definition of Program Command Buttons

- Restart – To exit setup mode and restart antenna again.
- Setup – To enter the setup mode.
- Get Antenna Information – To indicate the information on display after receiving it input to the antenna.
- Factory Setting – To initialize all antenna information to the default as same as ex-factory status.
- Load Default – To display the up-to-date information input to PC program.
- Update Default – To update the antenna information by the up-to-date information input to PC program.

Set Satellite Information

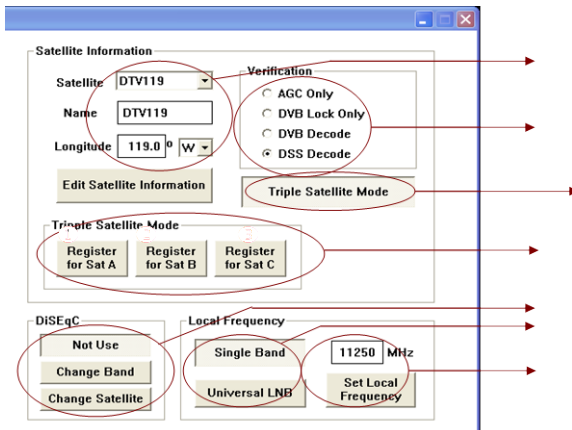

- **Satellite Information**

The name, longitude and confirmation method of the satellite is displayed when a satellite is selected in the list box. Push “Edit Satellite Information” button to update the information on modifying the value.

- **DiSEqC**

When the operation method of DiSEqC is selected to “Change Band”, DiSEqC may be used for updating the local frequency and to “Change Satellite”, for updating the target satellite.

- **Registration of target satellite**

In case that Tri-sat Mode is selected and the DiSEqC is selected to “Not Use”, only ❶ “Register for Sat A”, ❷ “Register for Sat B” and ❸ “Register for Sat A” and ❹ “Register for Sat B” are activated and the target satellite when DiSEqC is available may be registered by pushing ❸ and ❹ buttons.

- **Local Frequency**

In case that DiSEqC is selected to “Change Band”, be sure to push the “Universal LNB” button. In case that the DiSEqC is selected to “Not Use” or “Change Satellite”, be sure to push “Single Band” button and key in into the Local Frequency, and then push “Set Local Frequency” button.

Command Button

- Edit Satellite Information – To modify the satellite information.
- Tri- sat Mode – To use Triple Satellite.
- Register for Sat A – To register a satellite to satellite A.
- Register for Sat B – To register a satellite to satellite B.
- Register for Sat C – To register a satellite to satellite C.
- Not Use – Do not use DiSEqC.
- Change Band – To use DiSEqC to change band.
- Change Satellite – To use DiSEqC to change the satellite.
- Single Band – Antenna in use of Single LNB.
- Universal Band – Antenna in use of universal LNB.
- Set Local Frequency – To select local frequency of LNB.

Load and Update Default Command Button

- 1) Load Default: Click “load default” button to select *.rif file according to your region.

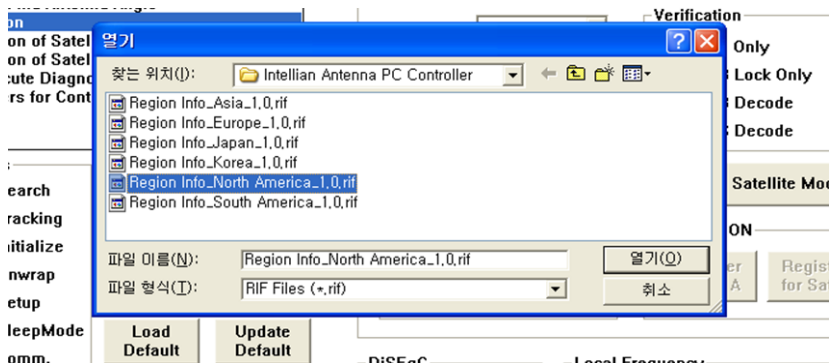

- 2) Update Default: Click “Update default” button to open update default Dialogue. Click “yes” button to update the system.

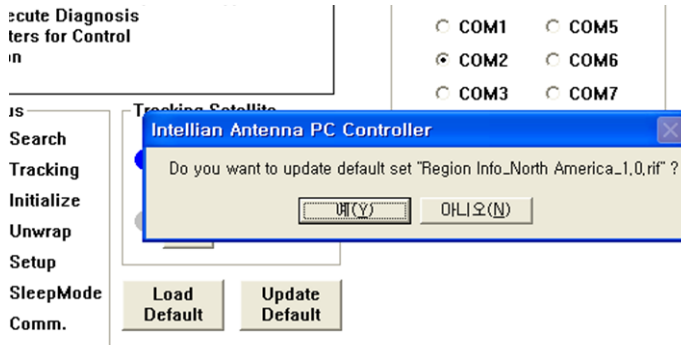

- 3) Click “confirm / yes” button to complete the update.

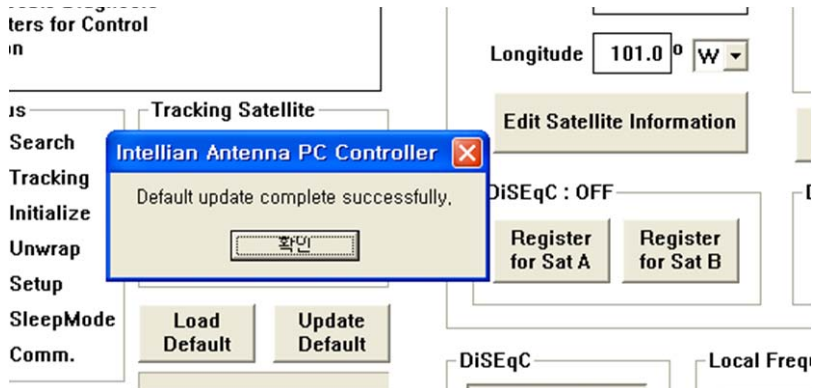

Controller menu

Set Antenna GPS and Find Antenna Angle

Antenna makes use of GPS information to search satellite quickly. The more precise the GPS information is, the quicker the antenna is able to search the satellite. The method to input information into GPS is to push “Set GPS” button after keying in the latitude and longitude information on “City GPS”. Pushing “Add City” button stores the GPS information. By selecting the stored region in the list box, the GPS information of such region is displayed. The Intellian i6/i6P satellite TV antenna system utilizes GPS data to locate the satellite faster.

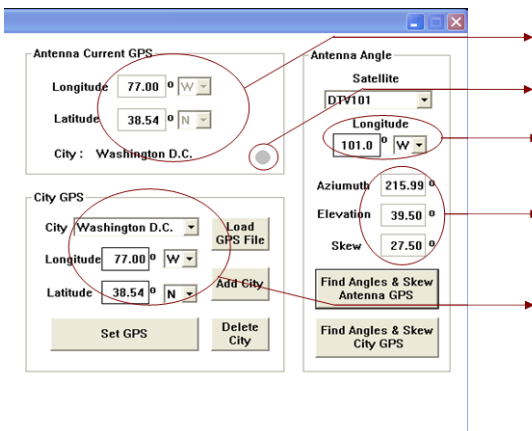

Command Buttons

- Load GPS Files – Reads in the various city information from the GPS files.
- Add City – Adds the name of city and its GPS information to GPS files
- Delete City – Deletes the name of city and its GPS information from the GPS files.
- Set GPS – Inputs the indicated GPS information on display to antenna.
- Find Angles & Skew Antenna GPS – Finds the current antenna angles and Skew angle in relation to the longitude of satellite and GPS.
- Find Angles & Skew City GPS – Finds the current city angles and Skew angle in relation to the latitude of satellite and GPS.

Set Tracking Information of Satellite [Primary]

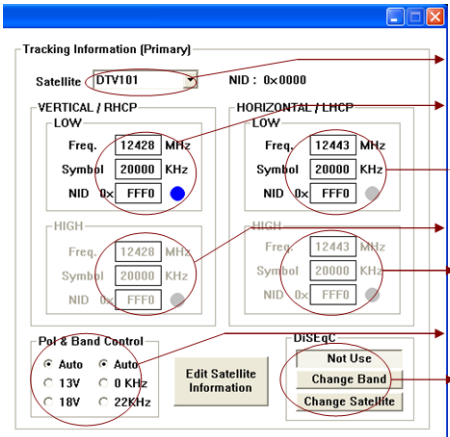

Command Button

- Edit Satellite Information – To change frequency information of the antenna
- Satellite Information – Satellite information consists of frequency, symbol and NID(Network ID) of a transponder in tracking satellite. There are four groups of satellite information. 'Vertical/RHCP' is applied when IRD supply 13V, and 'Horizontal/LHCP' is applied when IRD supply 18V. 'LOW' is applied when DiSEqC signal is not detected from IRD, 'HIGH' is applied when DiSEqC signal is detected from IRD. If you select 'Not Use' or 'Change Satellite', two 'HIGH' groups are inactivated. If you select
- Change Band', two 'High' groups are activated and you can modify satellite information which is applied when DiSEqC signal is detected from IRD. After modifying information, press 'Edit Satellite Information' button, then new information is updated in the antenna.
- Pol & Band Control – The power controls 13V, Vertical (RHCP) and 18V, Horizontal (LHCP) bands. The Band controls High and Low bands. (AUTO RRECOMMEDED)

AUTO & AUTO : 13V and 18V supplied to LNB without regard to IRD.
 AUTO & 0KHz : Low band supplied to LNB without regard to IRD
 AUTO & 22KHz : High band supplied to LNB without regard to IRD

13V & AUTO : 13V supplied to LNB without regard to IRD.

13V & 0KHz : 13V & Low band supplied to LNB without regard to IRD.

13V & 22KHz : 13V & High band supplied to LNB without regard to IRD.

18V & AUTO :18V supplied to LNB without regard to IRD.
 18V & 0KHz : 18V & Low band supplied to LNB without regard to IRD
 18V & 22KHz :18V & High band supplied to LNB without regard to IRD.

Set Tracking Information of Satellite [Secondary]

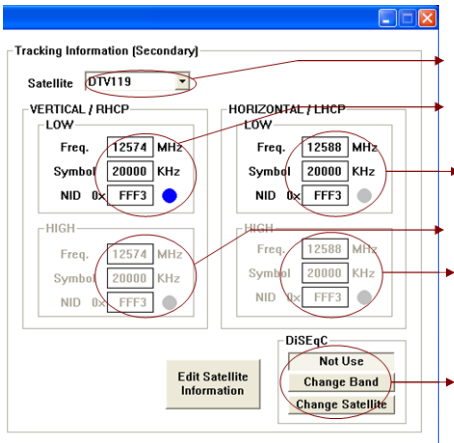

Command Button

- Edit Satellite Information – To change frequency information of the antenna.

Move Antenna and Execute Antenna Diagnosis

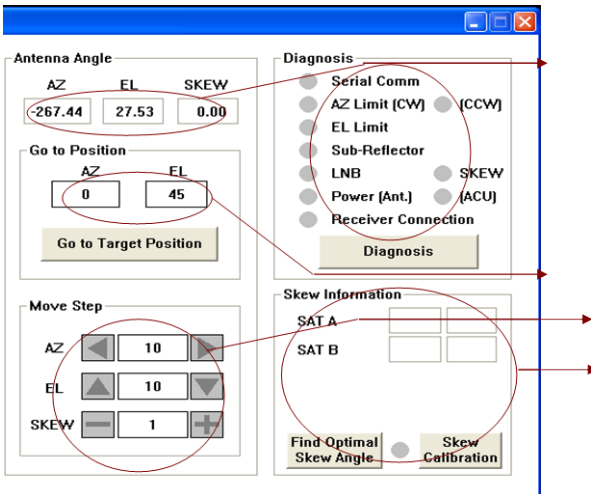

- **Angle of Antenna**
Two kinds of antenna movement is available. One is to move to the target position and the other is to move by certain amount of angle. The current position(angle) of the antenna is displayed as “Current” and to move to the target position, push “Go to target Position” button after keying in desired angle into “Target”. To move to a certain amount of angle only, move antenna to direction of up or down, and CW or CCW by using buttons after keying in the desired angle into the AZ and EL in the “Mover Step” box. Rotate LNB to direct the skew angle by using button.
- **Self-Diagnosis**
If “Diagnosis” button is pressed to carry out self- diagnosis of antenna, it displays the result of self-diagnosis after carrying it out. Blue circle means the antenna is normal; red represents abnormal and green represents the antenna is under diagnosis.

Command Button

- **Go to Target Position** – To move the antenna to the present position.
- **Diagnosis** – To diagnose the antenna (BLUE – Passed, RED – Failed, GREEN – Under diagnosis)

Set Antenna Parameters for Control

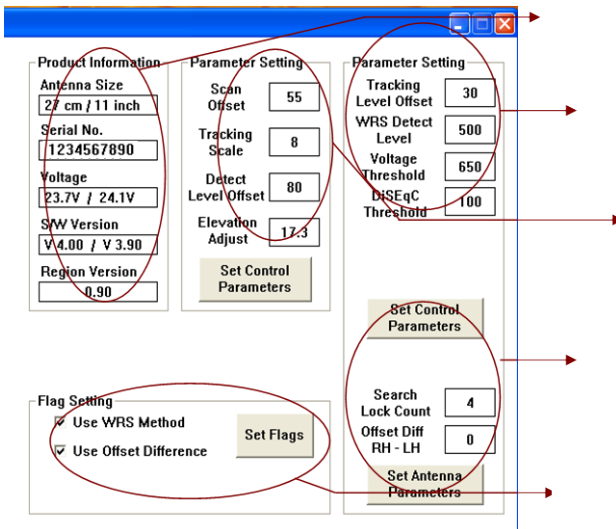

Command Buttons

Set Control Parameter– To register parameters values.

Set Flags – To set flag setting for WRS Method or Offset Difference.

Product Information – Antenna dish size. Serial NO, Voltage for antenna and ACU, Software version for ACU and Control.

Parameter Setting – To set antenna parameter values.

SCAN OFFSET : The actual angle between the marked point on sub-reflector and the datum.

TRACK SCALE : To control the tracking speed while antenna is tracking the satellite.

High track scale value resulting in high tracking speed.

DETECT LEVEL : The basic single detection level.

TRACKING LEVEL : The basic signal tracking level

EL ADJUST : The mechanical tolerance compensation of elevation limit.

WRS LEVEL : The basic WRS detect ion level.

VOLTAGE THRESHOLD :The value to identify Vertical/Horizontal or RHCP/LHCP

DISEQC THRESHOLD : The value to identify 22KHz tone.

OFFSET DIFFERENCE : The difference value between RHCP/LHCP and SCAN OFFSET .

USE WRS : To apply WRS while antenna is searching for satellite.

USE OFFSET DIFFERENCE : To apply Offset Difference.

Troubleshooting

Symptom	Possible cause*							
	1	2	3	4	5	6	7	8
Antenna not functioning	X							
No picture on TV set			X		X	X		X
Intermittent picture for short intervals		X	X	X	X	X		X
System works at the dock but not underway		X						
System will not find satellite		X	X	X	X	X	X	X
'Snowy' television picture				X				

Note : * for an explanation of possible cause and their remedies refer to the following paragraphs

1. Blown fuse, low power or wiring

Check that the in-line quick blow fuse (if fitted) has not blown or the circuit breaker has not tripped. Replace fuse with one of the same type and rating. If you have extended the power cable from the antenna unit, check that there is no power loss. Check the system wiring and connections.

2. Satellite signal blocked

Satellite signals can be blocked or degraded by buildings, other boats or equipment on your boat. Check to see if the antenna has a clear view of the sky.

3. Outside satellite coverage zone

Your system will provide excellent reception within the antenna coverage area for your satellite television service. However, signal quality may degrade as you approach the edges of this zone.

4. Radar interference

The energy levels radiated by radar units can overload the antenna a front-end circuits. Make sure that your antenna is installed as described in page 8; 'Selection of Installation Site'.

5. Incorrect or loose RF connectors

As part of the regular maintenance recommended by Intellian Technologies, Inc., all connections should be checked to ensure that they have not become loose. A loose RF connector can reduce signal quality.

6. Multi-switch interference

If you have multiple satellite receiver (IRD) connected to your system, make sure that you are using an active not passive multi-switch.

7. Satellite receiver (IRD) troubleshooting

Your satellite receiver (IRD) may be the cause of less than ideal operation.

- 1) Check the satellite receiver's (IRD's) configuration to ensure that it is programmed for the area in which you are operation.
- 2) Unplug the satellite receiver (IRD) from the power supply for 1 second. Reconnect and allow the system to initialize.

8. LNB fault

If you have an LNB fault, it may require replacing. Contact your local dealer, national distributor or Intellian Technologies, Inc. product support for further assistance.

Preparation for Transportation

This is to describe how to fix the antenna internally for transportation, and the following procedures to fix antenna shall be strictly observed to protect it from being damaged during transportation.

1. Refer to the drawing.
2. Rotate antenna left and right slowly till the limit switch is pressed.



WARNING

Don't rotate it quickly, or you may damage the antenna limit system.

3. Turn the antenna by 360° to the reverse direction.
4. Insert the sponge in both sides of the dish to fix the pedestal in position with the bottom radome.
5. Cover upper part of radome being careful for it's not touching the reflector, and then assemble upper part of radome.
6. Pack Intellian i6/i6P into the original package box.

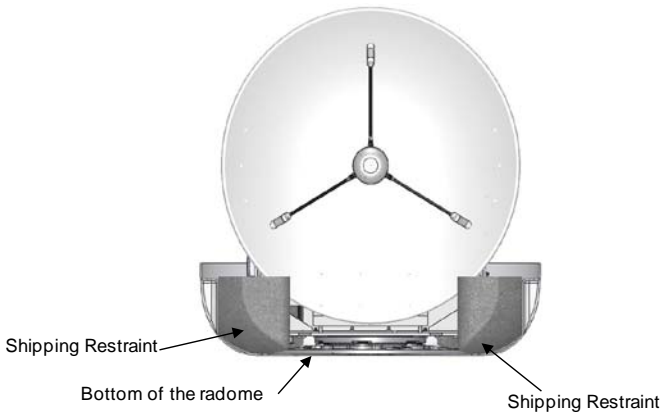

Warranty

This product is guaranteed by Intellian Technologies Inc., against defect due to faulty workmanship or materials and this guarantee covers for 2-year parts and 1-year labor for labor performed at Intellian Technologies, Inc. service center from the date of purchase of the product.

You are requested to present a copy of the purchase receipt issued by Intellian Technologies, Inc. that presents the date of purchase for after sales service under warranty. In case of failure to present the date of purchase, the warranty period is to be calculated to 30 days after the manufacturing production date.

If you discover a defect, Intellian Technologies, Inc. will, at its option, repair, replace or refund the purchase price of the product at no charge to you, provided you return it during the warranty period, transportation charges prepaid, to the factory direct. Please attach your name, address, telephone number, a description of the problem and a copy of the bill of sale or sales receipt as proof of date of original retail purchase, to each product returned to warranty service. Alternatively, you may bring the product to an Authorized Intellian Technologies, Inc. dealer/distributor for repair.

This Limited Warranty does not apply if the product has been damaged by accident, abuse, misuse or misapplication or has been modified without the written permission of Intellian Technologies, Inc.; if any Intellian Technologies, Inc. serial number has been removed or defaced; or if any factory-sealed part of the system has been opened without authorization

Appendix : Technical specification

General

Approvals	
CE – conforms to	EU Directive 89/336/EEC
FCC – verified to	CFR47:Part 15
Dimensions	
Satellite antenna unit	70cm (27.5") x 72cm(28.3")
Antenna dish diameter	60cm(23.6")
Antenna control unit	17.8cm(7")x21.68cm(8.5")x5.38cm(2.1")
Weight	
Satellite antenna unit	20kg (44 lbs)
Antenna control unit	1.2kg (2.6 lbs)
Environmental	
Operating temperature range	-15°C to +55°C
Storage temperature range	-25°C to +70°C
Humidity limit	95% R.H
Operating voltage	10.8 ~ 15.6 V DC
Power consumption	Typ. 30W, Max. 50W

Antenna system performance

Frequency	Ku-band(10.7 to 12.75 GHz)
Minimum EIRP	47dBW
Azimuth range	680°
Elevation range	+5° ~ +90°
Ship's motion	Roll $\pm 25^\circ$ Pitch $\pm 15^\circ$
Roll and pitch response rate	45° per second
Turn rate	45° per second



Intellian Technologies, Inc.

HQ Dongik Building 7th Fl.,
98 Nonhyun-Dong, Gangnam-gu,
Seoul 135-010, Korea
Tel : +82-2-515-4923
Fax: +82-2-545-4903

Factory SK Ventium 104-501,
522 Dangeong-Dong, Gunpo-Si,
Kyunggi-Do 435-776, Korea
Phone: +82-31-436-1488
Fax: +82-31-436-1489

R&D Center SK Ventium 104-601,
522 Dangeong-Dong, Gunpo-Si,
Kyunggi-Do 435-776, Korea
Phone: +82-31-436-2280
Fax: +82-31-436-2284

Intellian Technologies USA, Inc.

9261 Irvine Blvd.
Irvine, CA 92618 USA
Phone: +1-949-916-4411
Fax: +1-949-271-4183

E-Mail : customersupport@Intelliantech.com

Homepage : <http://www.Intelliantech.com>