

Intellian K4/K6 Serial Number



This serial number will be required for all troubleshooting or service calls made regarding this product.

Notice

All Right Reserved

Intellian K4/K6[®] and Intellian[®] are the registered trademarks of Intellian Technologies, Inc., and should not be appropriated without permission by Intellian Technologies, Inc., and the information contained in this manual is the property of Intellian Technologies, Inc. Any and all parts of this manual shall not be reproduced and distributed in any form without prior written consent by Intellian Technologies, Inc. The information contained in this manual shall be subject to change at any time without notice due to the functional upgrades of the product.

Copyright© Intellian Technologies, Inc.

Doc. No. K4/K6-AC V101

CONTENTS

INTRODUCTION	1
INTRODUCTION TO INTELLIAN K4/K6	1
FEATURES OF INTELLIAN K4/K6	2
BASIC SYSTEM CONFIGURATION	3
INSTALLATION	4
SYSTEM COMPONENTS	4
TOOLS REQUIRED FOR INSTALLATION	7
PLANNING THE INSTALLATION	8
INSTALLING THE DACU	15
CONNECTING THE SYSTEM TO A GPS	20
TARGET SATELLITE SETTING	21
OPERATION INSTRUCTION	22
INTRODUCTION	22
OPERATION USING THE DACU	23
DACU SOFT KEYS	23
NORMAL MODE	23
SET UP MODE	28
OPERATION USING PC CONTROLLER PROGRAM	51
INTRODUCTION	51
INSTALLATION USB TO SERIAL DRIVER	52
PROGRAM INITIALING AND SERIAL PORT SETUP	54
MAIN MENU – USING DEFAULT TRISAT MODE	55
SET SATELLITE INFORMATION	56
CONTROLLER MENU	59
TROUBLESHOOTING	64
PREPARATION FOR TRANSPORTATION	66
WARRANTY	67
APPENDIX: K6 TECHNICAL SPECIFICATION	68
APPENDIX: K4 TECHNICAL SPECIFICATION	69

INTRODUCTION

Introduction to Intellian K4/K6

Intellian K4/K6 is the world's first marine in-motion satellite TV antenna system that is compatible with the Ka-band broadcasts from DIRECTV's satellites, called 99°W and 103°W (the position related to Earth is expressed in longitude degrees). These satellites are now carrying the majority of DirecTV's HD programming.

This powerful and innovative design of the Intellian K4/K6 incorporates a plug-and-play system to control and support the Ku-band and Ka-band dual antenna system, which allows the users to enjoy both DIRECTV HD channels and standard channels at the same time. The Intellian automatic and fully-integrated dual antenna system offers users not only the simplest installation but also the most comfortable entertainment environment. As if at home, all a user needs to do is just switch the channel buttons on the TV remote control. Then, Intellian's dual antenna system will automatically recognize where the selected channel is located between Ku and Ka-band and change the satellite if necessary.

In addition, the Intellian K4/K6 19-inch rack-mount Dual Antenna Control Unit (DACU) allows for a hassle-free installation with its standard 8 receiver connector ports. This means that up to 8 receivers can be connected to the ACU from different locations on the vessel without additional multi-switches and wiring. Not to mention the Ku-band HD module and Multi-satellite Interface Module (MIM) are both embedded in the DACU which enables users to switch channels freely and simultaneously amongst DIRECTV's 5 satellites; 2 for Ka-band (99°W and 103°W) and 3 for Ku-band (101°W, 110°W, and 119°W)

Features of Intellian K4/K6

Full HD (High-Definition) Channel Availability

DIRECTV Ka-band signal reception for 99°W and 103°W satellites which are currently broadcasting more than 130 national HD channels.

Dual Antenna System

Enjoy watching channels from DIRECTV Ku-band satellites (101°W, 110°W, and 119°W) and Ka-band satellites (99°W and 103°W) simultaneously just like a home system, using Intellian's exclusive dual antenna system.

Wide Range Search (WRS) Algorithm

Since the Ka-band signal has a very narrow beam width, the searching time can be extended if the antenna system is using the conventional searching method to search only the main lobe. Intellian's patent-pending technology, WRS, can utilize the side lobe of the Ka-band signal and jump onto the main lobe directly which will shorten the searching time significantly.

Dynamic Beam Tilting (DBT) Technology

An advanced tracking technology is required for tracking the very narrow beam-width of the Ka-band signal. The DBT patent-pending technology allows the K4/K6 to have the most reliable and accurate tracking capability while the vessel is cruising at high speed or in rough sea conditions.

New Rack-Mount Dual Antenna Control Unit (DACU)

DACU controls dual antenna systems at one time, switches channels freely amongst DIRECTV's 5 satellites using TV remote control and includes built-in HD and MIM modules. Easily connects up to 8 receivers directly from different rooms without any extra multi-switches and wiring to the DACU's built-in 8 receiver connectors.

NMEA 0183 GPS Interface

A GPS Interface supports an external GPS which can provide the K4/K6 even higher performance.

Basic System Configuration

For your satellite TV system to work properly, the system will have to be connected with all of the provided components properly, as shown in the figure below (Refer to next chapter 'Installation' in this manual for more detailed connection instructions). Separate purchase of a satellite receiver and a TV is required.

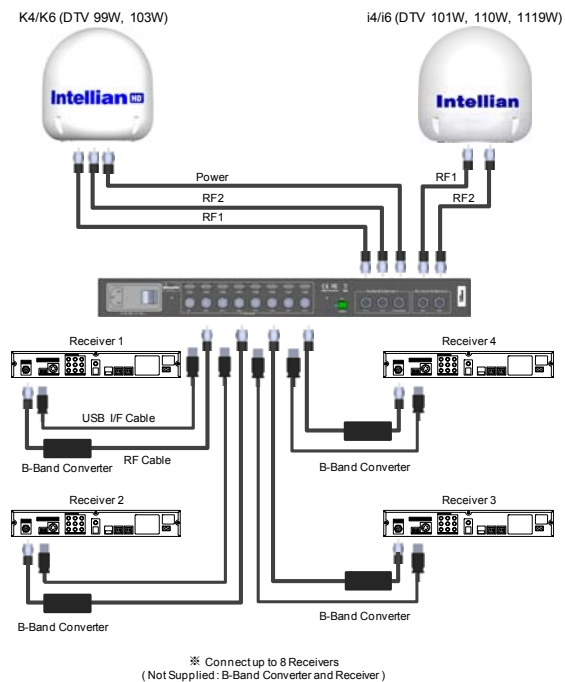

Installation

The components of the Intellian K4/K6 have been designed to be modular so that it is suitable for simple installation on all types of vessels.

System Components

Antenna Unit

The antenna of Intellian K4/K6 is composed with the following components for the optimum search and reception of the satellite signal.

- Mechanical Unit – manipulates the antenna to receive the optimal satellite signal regardless of the movement of the vessel.
- Dual Antenna Control Unit – controls mechanical operation of the K4/K6 and i4/i6 at same time.
- RF Unit – transmits the optimum satellite signal to the receiver.
- Radome – protects the antenna from the severe marine environment.



Dual Antenna Control Unit (DACU)

The Dual Antenna Control Unit (DACU) provides the power to the antenna and controls the various settings of the dual antenna simultaneously. Additionally, VFD (Vacuum Fluorescent Display) allows for you to operate the DACU in the dark.

The functions of the DACU are as follows:

- Control dual antenna systems at one time
- Connect up to 8 receivers directly
- Provide power for the antenna unit
- Monitor the antenna status
- Change the target satellite
- Set up the user environment
- Set up the receiver to be a Master receiver
- Set the current GPS information
- Set satellite information
- Move antenna manually
- Perform self-diagnosis of the antenna
- Set up the interface with a PC



Front



Rear

Installation Kit

Contain the items required for securing the antenna unit and DACU to your boat.

Antenna					ACU		
Hex Bolt SEA	Hex Head Wrench Bot SEA	Flat Washer 10EA	Spring Washer SEA	Hex Nut SEA	Tapping Screw (Ø4x16L) SEA	Flat Head Screw (M3x8L) 10EA	Sem's Bolt (M3x12L) SEA

Other Components

No	Components	Size	Q'ty
1	Rack Mounting Bracket	-	2EA
2	Table Mounting Bracket	-	2EA
3	RG6 (Antenna – DACU RF Cable)	15m	3EA
4	RG6 (Antenna – DACU Power Cable)	15m	1EA
5	RG6 (DACU – IRD Cable)	3m	1EA
6	AC Power Cable	1.5m	1EA
7	USB_Cable	1.8m	8EA
8	NMEA Connector	AK950-2	1EA
9	Hex Bolt	M8x50L	5EA
	Tapping Screw	Ø4x16L	5EA
	Flat Head Screw	M3x8L	10EA
	Sem's Bolt	M3x12L	5EA
	Flat Washer	M8	5EA
9	Spring Washer	M8	5EA
	Install CD	-	1 EA
11	Manual	-	1 EA
12	K4/K6 Mounting Template	-	1 EA
13	Quick Installation Guide	-	1EA

Tools Required for Installation



Planning the installation

Selection of Installation Site

Install the antenna in accordance with the following procedures to insure maximum performance of the antenna.

The ideal antenna site has a clear view of the horizon/satellite all around. Please be sure there are no obstacles within 15 degrees above the antenna. Any obstacles located above a 15 degree elevation can prevent the antenna from tracking the satellite signal (Refer to the drawing).

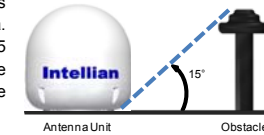

Keep the antenna out of line with nearby radars, as their energy levels may overload the antenna front-end circuits. If necessary, position the antenna unit so it is at least four feet (1.2 meters) above or below the level of the radar.

Make sure that the mounting surface is rigid, so that it will not flex when the vessel vibrates. If necessary, add a stiffening member to the mounting site to strengthen it.

The movement of the antenna can be minimized by installing it at the center of the ship. For optimal performance of the antenna, it is not recommended to install at any corner of the ship, where the movement of the ship is the greatest.

Install the bottom of the antenna parallel to the surface of the sea and fix tightly to the structure of the ship.

When setting the antenna down, be careful not to have the RF connector. Striking the connector on the bottom directly will damage the connector and make connection impossible.

Cables

Before installing the system cables, you need to take the following points into consideration.

- All cables need to be well clamped and protected from physical damage and exposure to heat and humidity.
- Cable with an acute bend is not allowed.
- Where a cable passes through an exposed bulkhead or deck head, a watertight gland or swan neck tube should be used.

Power requirements

You need to follow the power requirements to avoid damage the system.

Intellian K4/K6 has been designed to work on a boat's power supply rated from 90 ~ 260V AC.

If your IRD(s) and television(s) require a 110V/240V AC power supply, you will need to install a suitable DC to AC converter to operate the unit(s) from your boat's DC power supply.

Extending the Cables

The cables that have been supplied with your Intellian system should be of adequate length to complete the installation on most boats.

Antenna – DACU RF and DACU Power Cable

This cable is supplied at a length of 15m. If a longer length is required you should replace this cable with an extended RF cable supplied by Intellian Technologies.



WARNING

Exceeding the indicated cable lengths will result in reduced performance of your system.

Installation and Mounting of antenna

The method of installation and mounting of antenna may vary with vessel design but the following procedures are applicable in most situations, and will result in a secure and effective installation.

Confirmation of size prior to installation

- Confirm the height and diameter of the bottom surface of the antenna before installing it.
- The space must be sufficient for installing the antenna unit considering the height and diameter of the antenna.
- The height and the diameter of the bottom surface of the antenna are as shown in the following drawing. If possible, install the antenna using a power tower.

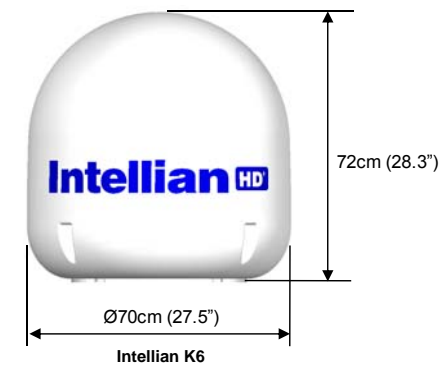

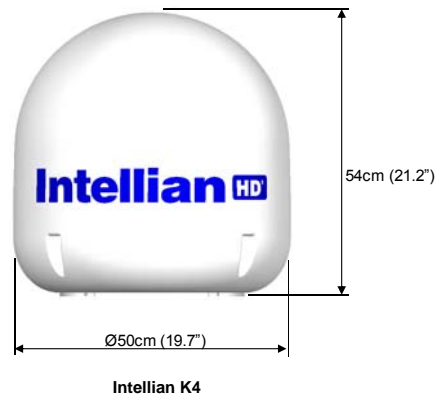
**WARNING**

Before installing the antenna you have to remove the radome and remove the shipping foam from the antenna interior. Replace the radome before installation.

Mark of the antenna mounting position

Referring to the mounting template, mark where antenna is to be mounted onboard the ship (it must be a flat surface) or on a separate power tower by drawing below.

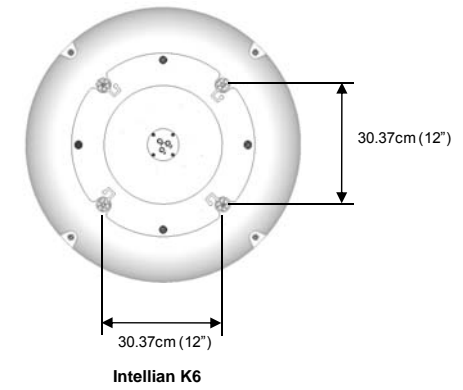

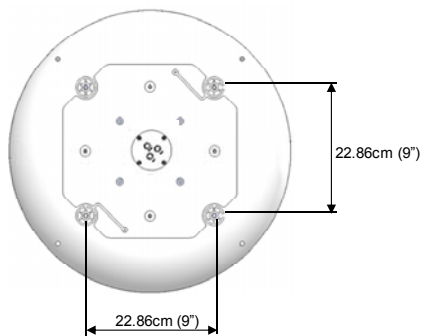

Intellian K4

**WARNING**

If a power tower is not suit to mount the antenna, separate cable shock and waterproofing measures must be taken to protect the RF connector from begin exposed to the sea water and external shocks. An exposed cable may cause electric shock and cause serious damage to the equipment.

Securing hole for bolts and cable way

Make 4 bolt holes of 10mm diameter, one at each corner of a rectangle drawn as above, and make a circular hole of 80mm diameter at the center of the rectangle, through which the cable will run.

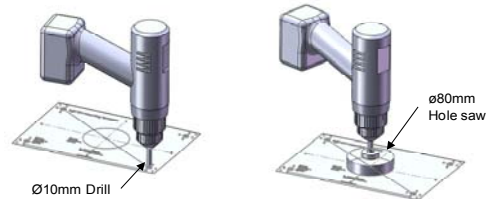
**Connection of the RF cable**

Remove the rubber protector from RF connector. Connect the RF cable to the RF connector under the base plate through the access hole using an 11mm spanner. Be careful not to tighten it too much, as you may damage the connector.

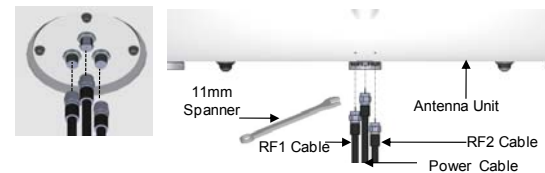
**WARNING**

Do not use excessive force when using the spanner, this will damage the threads. Be careful that the connectors do not contact the mounting surface of the antenna, this may cause a critical malfunction and serious damage to the equipment.

Mounting the antenna

Attach the antenna by using the hex head bolts (M8X50L), M8 spring washers, and M8 flat washers supplied.

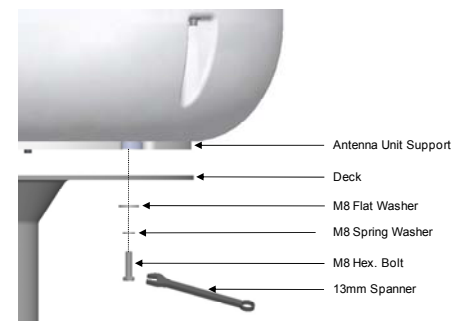

Installing the DACU

DACU dimensions

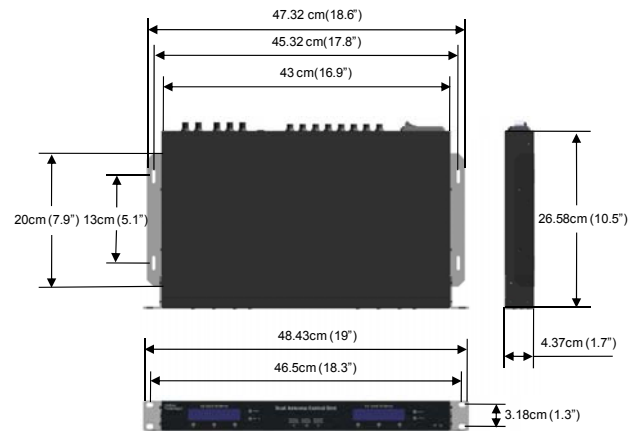

Selection of Installation Site

The DACU should be installed below deck, in a location that is :

- Dry, cool, and ventilated.
- Easy accessible from your main TV viewing area.

To Install the DACU

Intellian supplies two type of mounting methods (a)Table Mount Type and (b)19" Rack Mount Type to mount your DACU.

(a) Table Mount Type

1. The DACU should be installed using the two supplied Table Mounting Brackets which allow for a top or bottom mounting configuration.
2. Using the self tapping screws supplied, attach the mounting brackets to the sides of the DACU.
3. Place the DACU in the location where it is going to be installed.
4. Connect the cables to the rear of the DACU.
5. Using a pencil to mark the 4 hole positions (2 each side), and use the appropriate drill bit to drill them.

(b) 19" Rack Mount Type

1. The DACU should be installed using the two supplied Rack Mounting Brackets which allow for a side 19" rack mounting configuration.
2. Using the self tapping screws supplied, attach the mounting brackets to the sides of the DACU.
3. Place the DACU in the location where it is going to be installed.
4. Connect the cables to the rear of the DACU.
5. Using a pencil to mark the 8 hole positions (4 each side), and use the appropriate drill bit to drill them.



(a) Table Mount Type



(b) 19" Rack Mount Type

Connecting the System Cables

After installation and fixation of the antenna, connect the DACU to the antenna. Refer the drawing below to connect cables.



WARNING

It will cause a critical malfunction if you do not follow the system diagram to complete the system cable connections as below.

Single and Multi-IRD Connection

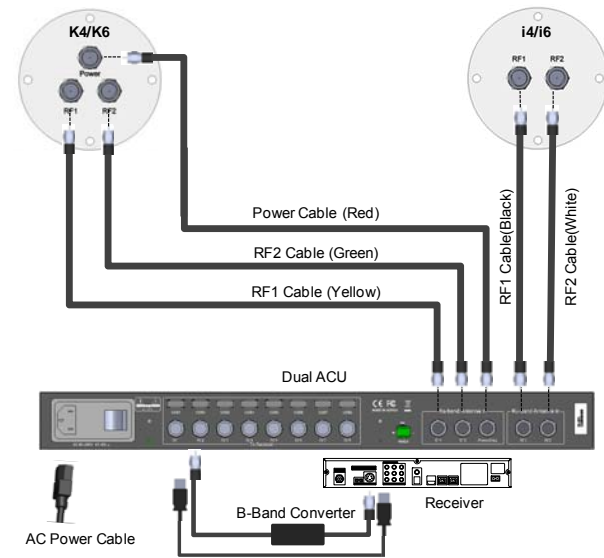

Intellian K4/K6

- Connect the RF1 Cable (Yellow/15m) from the RF 1 connector on the antenna to the RF1 connector at Ka-band Antenna In section on the rear of DACU.
- Connect the RF2 Cable (Green/15m) from the RF 2 connector on the antenna to the RF2 connector at Ka-band Antenna In section on the rear of DACU.
- Connect the Power Cable (Red/15m) from the Power connector on the antenna to the Power/Data connector at Ka-band Antenna In section on the rear of DACU.

Intellian i4/i6

- Connect the RF1 Cable (Black/15m) from the RF 1 connector on the antenna to the RF1 connector at Ku-band Antenna In section on the rear of DACU.
- Connect the RF2 Cable (White/15m) from the RF 2 connector on the antenna to the RF2 connector at Ku-band Antenna In section on the rear of DACU.

Receivers

- Connect the B-Band Converter (not supplied) to the RF connector on the rear of the receiver.
- Connect the DACU-IRD Cable (3m) from the RF1 connector at To Receiver Section on the rear of the DACU to RF connector on the B-Band Converter.
- Connect USB-cable (1.8m) from the USB1 connector at To Receiver Section on the rear of the DACU to the USB connector on the receiver.
- Connect the AC power cable (1.5m) from AC power connector on the rear of DACU to a power source from 90~ 260 V AC.
- Press the POWER ON switch on the rear of the DACU to start the operation of the antenna system automatically.

Connecting the system to a GPS

For improved satellite tracking, you can connect your satellite TV system directly to your boat's NMEA 0183 GPS system. To do this you will need lengths of cable suitable for connecting to your GPS system and the green 2-way DACU GPS connector supplied with your Intellian K4/K6 Satellite TV System.

To connect the system to a GPS

1. Strip back the insulation of each cable and connect a cable to each terminal of the 2-way connector.
2. Tighten the locking screws.
3. Connect the cable from the **+ve** (positive) terminal of the DACU GPS connector to the NMEA **OUT** wire of the boat's GPS system.
4. Connect the cable from the **-ve** (negative) terminal of the DACU GPS connector to the **ground wire** of the boat's GPS system.
5. Refit the DACU GPS connector to the rear of the DACU.



Target Satellite Setting

You can select the target satellite to receive satellite signal from. If the target satellite is not on the list you will have to register the target satellite.

GPS Setting

You can input the GPS information through the DACU or the PC Program. To setting the GPS information, the antenna system has to be in 'SET UP mode'. For detailed instructions, please refer to page 38; 'Setting the GPS', and page 59; 'Set Antenna GPS and find Antenna Angle'.

Satellite registration

You can register the target satellite through the DACU or the PC program. To register the target satellite, the antenna system has to be in 'SET UP mode' and the required information is, Satellite name, Satellite Longitude, Method of Satellite Identification, Frequency of each of the band, Symbol Rate, Network ID, Power Change method. For detailed instructions, please refer to page 31; 'Edit Satellite Information', page 56; 'Set Satellite Information', and page 60; 'Set Tracking Information of Satellite'.

Satellite Pair Selection

You can select the Satellite Pair from the list through the DACU or the PC program. You can easily select the target satellite from the satellite pair. For detailed instructions please refer to page 29; 'Setting the Satellite pair', page 56; 'Set Satellite Information'.

Target Satellite Selection

Choose the target satellite from the Satellite Pair. When selecting through the DACU, you have to press the left button to select the target satellite while the antenna system is in either 'Searching Mode' or 'Tracking Mode'. When using the PC program you can select either satellite 'A' or satellite 'B' from 'Tracking Satellite' at anytime.

Operation Instruction

Introduction

This section of the handbook describes how to set up your Satellite TV System after installation using the DACU or PC controller program and includes the following functions:

- System starts up.
- Changing the default satellite.
- Monitoring the antenna status.
- Setting sleep mode.
- Entering setup mode.
- Setting the satellite pair.
- Editing satellite information.
- Setting the antenna parameter.
- Setting the LNB local frequency.
- Setting GPS.
- Setting the DiSEqC method.
- Display versions.
- Display power status.
- Setting antenna go position.
- Setting antenna move step.
- Setting remote control.
- Setting the factory default parameters.
- Performing diagnostic tests.



WARNING

Note: Many of the above functions will only be required only after initial installation of your system. Refer to the **Quick Installation Guide** before operating the system.

Operation Using the DACU

DACU Soft Keys





Normal Mode

Start Up (K4/K6)

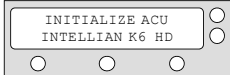
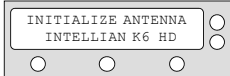
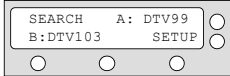
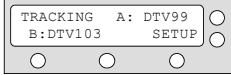
With the system installed and power applied, the DACU screen will show the following sequence:

1. Communication is being established between the antenna and the DACU. The DACU initialized.
 
2. The antenna is initialized.
 
3. The antenna is searching for Satellite A.
 
4. The antenna has located the satellite and is now tracking.
 

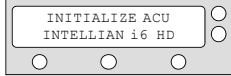
Start Up (i4/i6)

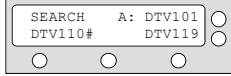
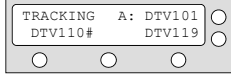
1. Communication is being established between the antenna and the DACU. The DACU initialized.
 
2. The antenna is initialized.
 
3. The antenna is searching for Satellite A.
 
4. The antenna has located the satellite and is now tracking.
 



WARNING

The operation method is exactly same for both K4/K6 and i4/i6. The below instruction will be explained using the i4/i6 as example.

Change of Target Satellite

Your antenna is programmed with three candidates of target satellites as default mode. To change the target satellite, press LEFT soft key. The target satellite is changed and is automatically tracked by the antenna.

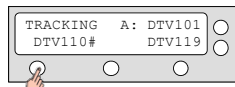

1. Press LFET soft key for tracking Satellite B.

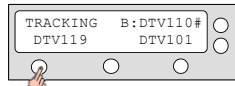

2. The antenna is tracking Satellite B.

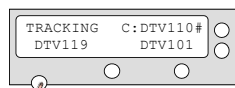

3. Press LFET soft key for tracking Satellite C.

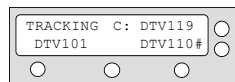

4. The antenna is tracking Satellite C.

Monitoring the current status of the antenna

While POWER ON, DACU displays the status of the antenna. The various DACU displays may be shown according to the current status of the antenna.

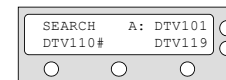

1. The antenna is searching for Satellite A.

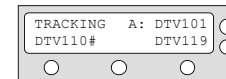

2. The antenna is tracking Satellite A.

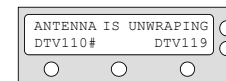

3. The antenna is unwrapping the cable.

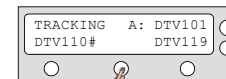

4. The antenna is again tracking satellite A. Press center soft key to display position detail.



5. Antenna position detail and signal strength are displayed.



6. Press center soft key to display current GPS information. Press center soft key to return to main tracking mode.

Sleep Mode

If the antenna lost the tracking satellite in sleep mode, sleep mode is cancelled.

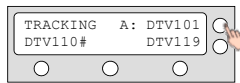

1. Press BACK to enter sleep mode.

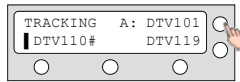

2. Press Back again for exiting sleep mode.

Set Up Mode

Begin Set-Up Mode

To enter the Set-up Mode simply follow the instructions below:

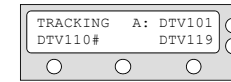

1. With the antenna tracking .



2. Press ENTER to enter setup mode.
Press BACK to exit setup mode.



3. Press Yes to set the satellite pair.

Setting the Satellite Pair

You can change the satellite pair if you decide to receive satellite television service from a different service provider.

Example1. Changing the target satellite without using DiSEqC:

1. Press ENTER to enter setup mode.
2. Press YES to set satellite pair.
3. Press YES to set triple satellites.
4. Set satellite A
Press PREV to show previous satellite name.
Press SELECT to set chosen satellite to SAT A.
Press NEXT to show next satellite name.
5. Set satellite B
Press PREV to show previous satellite name.
Press SELECT to set chosen satellite to SAT B.
Press NEXT to show next satellite name.
6. Set satellite C
Press PREV to show previous satellite name.
Press SELECT to set chosen satellite to SAT C.
Press NEXT to show next satellite name.
7. Press YES to save selections.
Press NO to cancel and return to main setup mode.

Example2. Changing the target satellite using DiSEqC:

1. Press YES to enter setup mode.
2. Press YES to set satellite pair.
3. Set satellite A
Press PREV to show previous satellite name.
Press SELECT to set chosen satellite to SAT A.
Press NEXT to show next satellite name.
4. Set satellite B
Press PREV to show previous satellite name.
Press SELECT to set chosen satellite to SAT B.
Press NEXT to show next satellite name.
5. Set satellite A* when DiSEqC is active from IRD.
Press PREV to show previous satellite name.
Press SELECT to set chosen satellite to SAT A*.
Press NEXT to show next satellite name.
6. Set satellite B* when DiSEqC is active from IRD.
Press PREV to show previous satellite name.
Press SELECT to set chosen satellite to SAT B*.
Press NEXT to show next satellite name.
7. Press YES to save selections.
Press NO to cancel and return to main setup mode.

Edit Satellite information

It is possible to modify the existing satellite information and input new satellite information into the ACU as well. It is not recommended for a novice satellite service user to use this mode.

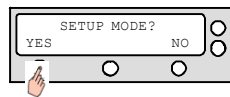

1. Press YES to enter setup mode.

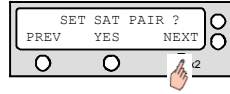

2. Press NEXT twice to enter edit satellite info mode.



3. Press YES to edit satellite info.

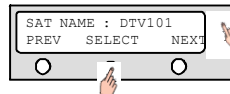

4. Set the satellite name.
 PREV – Shows previous satellite name.
 SELECT – Select the displayed satellite for editing.
 NEXT – Shows next satellite name.
 Press ENTER to move to next screen.

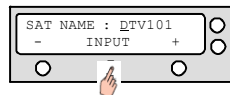

5. Input the satellite name.
 + Increases the value. - decreases the value.
 Change the underscored digit using the +/- buttons.
 Press INPUT to accept the value and move to next digit. Press BACK to move to previous digit.

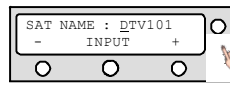

6. Press ENTER to move to next screen.
 Press BACK to return previous screen.

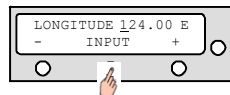

7. Input the satellite position.
 +increases a value. – decreases a value.
 Change the underscored digit using the +/- buttons.
 Press INPUT to accept the value and move to next digit. Press BACK to move to previous digit.

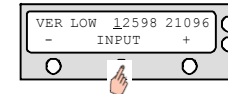

8. Input the tracking frequency (MHz) and symbol rate (KHz) for vertical low band.

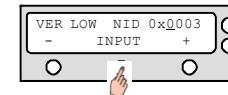

9. Input the network ID (NID) for vertical low band.

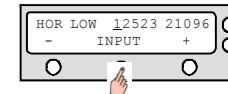

10. Input the tracking frequency (MHz) and symbol rate (KHz) for horizontal low band.

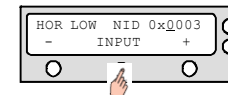

11. Input the network ID (NID) for horizontal low band.

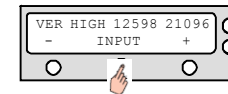

12. Input the tracking frequency (MHz) and symbol rate (KHz) for vertical high band.

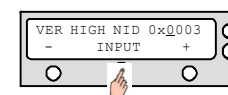

13. Input the network ID (NID) for vertical high band.

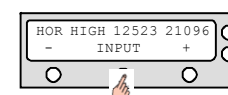

14. Input the tracking frequency (MHz) and symbol rate (KHz) for horizontal high band.

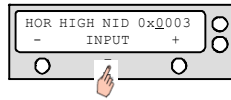

15. Input the network ID (NID) for horizontal high band.

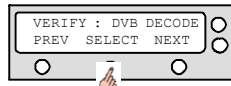

16. Select the verification method¹⁾ of tracking satellite.
PREV – Shows previous method.
SELECT – Set the displayed method.
NEXT – Shows next method.

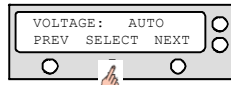

17. Select the voltage supply method²⁾ to LNB (AUTO recommended)

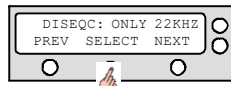

18. Select the DISEQC method³⁾ (AUTO recommended)

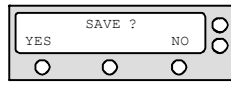

19. Press YES to save the input information.
Press NO to cancel and return to main setup mode.

1) Verification method

- SIGNAL – use only signal level for tracking
- DVB LOCK – use only DVB Lock signal for tracking
- DVB DECODE – verify satellite using DVB decoding method for tracking
- DSS DECODE – decode only DSS Lock signal for tracking

2) Voltage supply method

- AUTO- change voltage to LNB by IRD voltage
- ONLY 13V – always supply 13V to LNB
- ONLY 18V – always supply 18V to LNB

3) DISEQC method

- AUTO – change signal to LNB by IRD DISEQC
- ONLY 0KHZ – always supply 0kHz to LNB
- ONLY 22KHZ - always supply 22kHz to LNB

Setting the Antenna Parameters

It is not recommended for a novice satellite service user to use this mode.
Consult Intellian for changing antenna parameters.

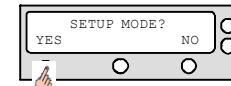

1. Press YES to enter setup mode.

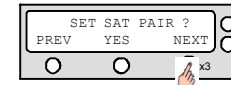

2. Press NEXT three times to enter set antenna parameter mode.

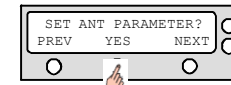

3. Press YES to set antenna parameter.

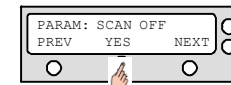

4. Select the PARAM¹⁾ – SCAN OFF
PREV – Shows previous parameter.
SELECT – Set the displayed parameter.
NEXT – Shows next parameter.
Press ENTER to move to next screen.

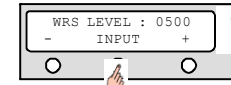

5. Input the WRS LEVEL.
+increases the value. – decreases the value.
Change the underscored digit using the +/- buttons.
Press INPUT to accept the value and move to next digit. Press BACK to move to previous digit.
Press ENTER to move to next screen.



6. Press YES to save the input information.
Press NO to cancel and return to main setup mode.

1) Parameter Setting method

SCAN OFFSET – The actual angle between the marked point on the sub-reflector and the datum.

TRACK SCALE – To control the tracking speed while antenna is tracking the satellite. High Track Scale value resulting in high tracking speed.

DETECT LEVEL – The basic single detection level.

TRACKING LEVEL – The basic signal tracking level

ELADJUST – The mechanical tolerance compensation of elevation limit.

WRS LEVEL – The basic WRS detection level.

POWER THRESHOLD – The value to identify Vertical/Horizontal or RHCP/LHCP.

DISEQC LEVEL – The value to identify 22KHz tone.

OFFSET RH-LH – The difference value between RHCP/LHCP and SCAN OFFSET.

USE WRS – To apply WRS while antenna is searching for satellite.

OFFSET DIFFERENCE – To apply Offset Difference.

Setting the LNB local frequency

It is possible to select a local frequency from DACU. It is not recommended for a novice satellite service user to use this mode.

CASE 1. Single band LNB is used.

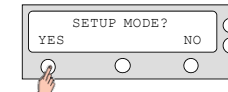

1. Press YES to enter setup mode.

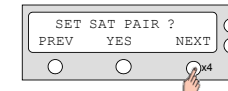

2. Press NEXT four times to enter set local frequency mode.



3. Press YES to set local frequency.

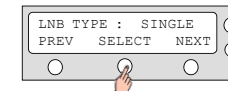

4. Select the LNB Type ¹⁾– SINGLE.
PREV – Shows previous LNB type.
SELECT – Set the displayed LNB type.
NEXT – Shows next LNB type.
Press ENTER to move to next screen.

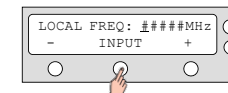

5. Input the local frequency of LNB.
+increases the value. – decreases the value.
Change the underscored digit using the +/- buttons. Press INPUT to accept the value and move to next digit. Press BACK to move to previous digit. Press ENTER to move to next screen.



6. Press YES to accept the data.
Press NO to cancel and return to main setup mode.

CASE 2 Universal LNB is used. (Low band local frequency-9750 MHz/ High band local frequency 10600 MHz)

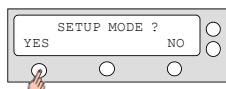

1. Press YES to enter setup mode.



2. Press NEXT four times to enter set local frequency mode.



3. Press YES to set local frequency.

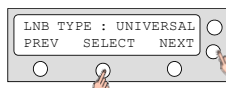

4. Select the LNB Type ¹⁾– UNIVERSAL.
 PREV – Shows previous LNB type.
 SELECT – Set the displayed LNB type.
 NEXT – Shows next LNB type.
 Press ENTER to move to next screen.



5. Press YES to accept the data.
 Press NO to cancel and return to main setup mode.

1) LNB Type

SINGLE: Single Band LNB

Asia 11300 MHz, Japan 10678MHz, Korea 10750MHz, America 11250MHz
 DirecTV Ka-band LNB 18050 MHz

UNIVERSAL : Universal LNB

Low band local frequency -9750 MHz
 High band local frequency -10600 MHz

Setting the GPS

It is possible to set up and modify the GPS information, which enhances the antenna functionality.

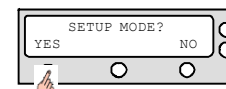

1. Press YES to enter setup mode.

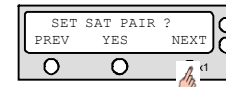

2. Press NEXT to enter GPS setup mode.

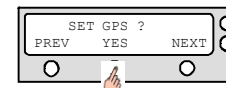

3. Press YES to set GPS.



4. Input the longitude data.
 +increases the value. – decreases the value.
 Change the underscored digit using the +/- buttons.
 Press INPUT to accept the value and move to next digit. Press BACK to move to previous digit.

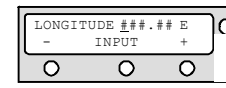

5. Press ENTER to move to next screen.
 Press BACK to move to previous screen.

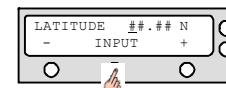

6. Input the latitude data.
 +increases the value. – decreases the value.
 Change the underscored digit using the +/- buttons.
 Press INPUT to accept the value and move to next digit. Press Back to move to previous digit.



7. Press YES to accept data.
 Press NO to cancel and return to main setup mode.

Setting the DiSEqC Method

DiSEqC selection can be made from ACU. It is not recommended for a novice satellite service user this mode.

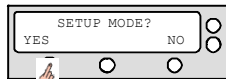

1. Press YES to enter setup mode.

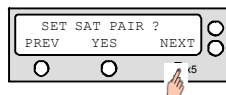

2. Press NEXT five times to enter DISEQC mode.



3. Press YES to use DISEQC.

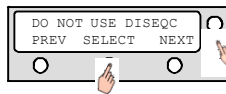

4. Select the DiSEqC Method¹⁾
 PREV – Shows previous DiSEqC Method.
 SELECT/ENTER – Set the displayed DiSEqC method.
 NEXT– Shows next DiSEqC Method.
 Press ENTER to move to next screen.



5. Press YES to accept the selection.
 Press NO to cancel and return to main setup mode.

1) DiSEqC method
 DO NOT USE DISEQC – DiSEqC is not in using.
 USE TO CHANGE BAND – DiSEqC is used to change to low and high band.
 USE TO CHANGE SAT – DiSEqC is used to change tracking satellite.

Display Versions

This sequence enables you to see what version of antenna and DACU software version are installed on your system.

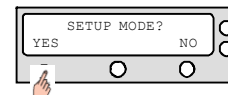

1. Press YES to enter setup mode.

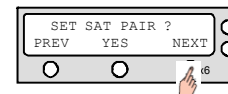

2. Press NEXT six times to enter the view version mode.



3. Press YES to view version.

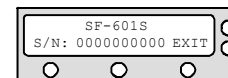

4. Antenna product name and S/N are shown.
 Press center soft key to view antenna software version. Press EXIT to return to main setup mode.

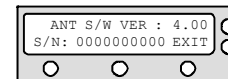

5. Antenna software version and S/N are shown.
 Press center soft key to view ACU software version. Press EXIT to return to main setup mode.

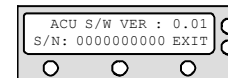

6. ACU software version and S/N are shown.
 Press EXIT to return to main setup mode.

Display Power

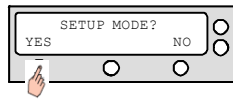

1. Press YES to enter setup mode.

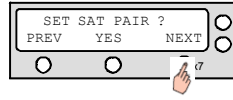

2. Press NEXT seven times to enter the view power mode.

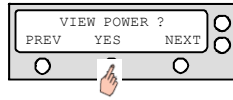

3. Press YES to view power.

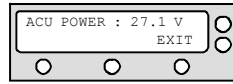

4. ACU Voltage is shown.
Press center soft key to view antenna voltage.
Press EXIT to return to main setup mode.

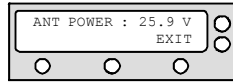

5. Antenna Voltage is shown.
Press center soft key to view IRD Voltage and frequency. Press EXIT to return to main setup mode.

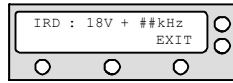

6. IRD Voltage and frequency are shown.
Press EXIT to return to main setup mode.

Setting Remote Control

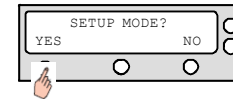

1. Press YES to enter setup mode.

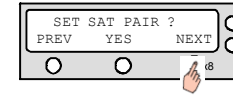

2. Press NEXT eight times to enter remote control setting mode.

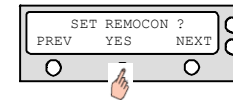

3. Press YES to set remote control.

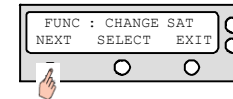

4. Select the Function¹⁾
NEXT – Shows next function.

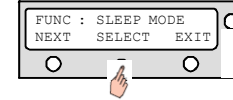

5. SELECT/ENTER –Registers a key on remote control.



6. Point remote control to ACU .
Press any key on remote control for selected function and press same key again for confirmation.
Press BACK to move to previous screen.
Press EXIT to return to main setup mode.

Setting Antenna Go Position

The antenna can be controlled manually by using DACU.

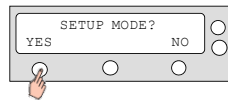

1. Press YES to enter setup mode.

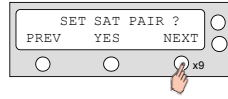

2. Press NEXT nine times to enter the antenna go position mode.



3. Press YES to go position.

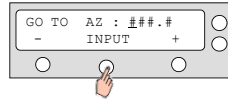

4. Input position value for azimuth (AZ) axis.
+ increases the value, - decreases the value.
Change the underscored digit using the +/- buttons.
Press INPUT to accept the value and move to next digit. Press BACK to move to previous digit.
Press ENTER to move to next screen.



5. Input position value for elevation (EL) axis.
+ increases the value, - decreases the value.
Change the underscored digit using the +/- buttons.
Press INPUT to accept the value and move to next digit. Press BACK to move to previous digit.
Press ENTER to move to next screen.

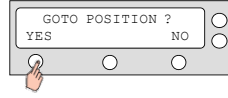

6. Press YES to move the antenna to input position.
Press NO to return to the Antenna Go Position mode.



7. Press EXIT to return to main setup mode.

Setting Antenna Move Step

The antenna may be moved by 1° step manually by using DACU.

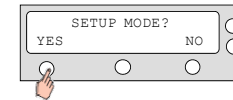

1. Press YES to enter setup mode.

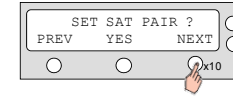

2. Press NEXT ten times to enter the antenna move step mode.

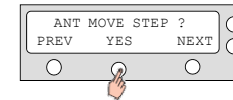

3. Press YES to move step.

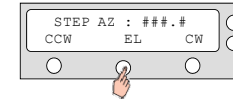

4. Move the antenna in the azimuth (AZ) axis.
CW – Move the antenna clockwise.
CCW – Move the antenna counter-clockwise.
EL – Go to elevation control screen.



5. Move the antenna in the elevation (EL) axis.
UP – Move the antenna up.
DOWN – Move the antenna down.
EXIT – Return to Antenna Move Step mode.



7. If failed to press same key twice, TRY AGAIN will be displayed.



8. If failed to register a free key, KEY IS USING will be displayed.



9. REMOTE KEY REGISTERED will be displayed if key has been properly registered.



10. Press NEXT to shows next function. Press EXIT to return to main setup mode.

- 1) Function
- CHANGE SAT
- SLEEP MODE
- CLEAR REGISTERED KEY

Change the target satellite.
Enter sleep mode.
Clear registered key.

Setting Multi-satellite Interface Module (MIM)

Up to 8 IRDs can be connected to DACU and every IRD connected to DACU can be a Master which can change the target satellite freely by selecting a channel. Follow the steps below to enable/ disable this function.



1. Press YES to enter setup mode.

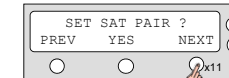

2. Press NEXT eleven times to enter the set MIM mode.

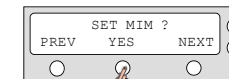

3. Press YES to set MIM.



4. Press ON
Press ENTER to move to next screen.



5. Press YES to save selections.
Press NO to cancel and return to main setup mode

Executing Antenna Diagnosis

It is possible to see the antenna status by reviewing the result of diagnosis of the antenna. Refer to the following codes, to understand the diagnosis results.

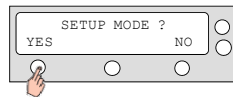

1. Press YES to enter setup mode.

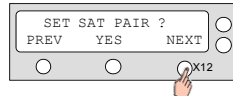

2. Press NEXT twelve times to enter Antenna Diagnosis mode.

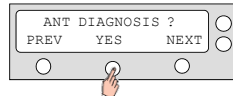

3. Press YES to diagnosis antenna.

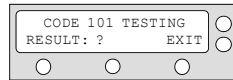

4. CODE 101 is being tested.
Press EXIT to return to main setup mode.

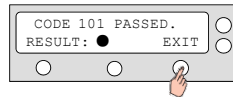

5. CODE¹⁾ 101 has passed.
Press EXIT to return to main setup mode.

CODE 101 : Communication between antenna and antenna control unit is tested.
If failed, check the power and data cable.

CODE 102 : AZ CW limit is tested.
If failed, check the limit sensors, motor, and belt for AZ axis.

CODE 103 : AZ CCW limit is tested.
If failed, check the limit sensors, motor, and belt for AZ axis.

CODE 104 : EL axis is tested.
If failed, check the limit sensors, motor, and belt for EL axis.

CODE 105 : Sub-reflector is tested.
If failed, check the sub-reflector.

CODE 106 : LNB is tested.
If failed, check the LNB and control board.

CODE 107 : Skew System tested.
If failed, check the control board, skew motor, and skew sensor

CODE 108 : Antenna Input Power tested.
If failed, check the RF cable.

CODE 109 : ACU Power tested.
If failed, check the ACU power cable and Input DC power.

CODE 110 : IRD Power tested.
If failed, check the ACU to IRD cable and IRD power.

RESULT STATUS : ● is pass. Number is fail(●●3●●●●8●●). And ? Is Testing.

Setting Region

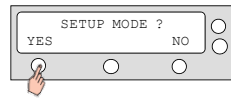

1. Press YES to enter setup mode.

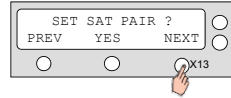

2. Press NEXT thirteen times to enter Load Region Information mode.

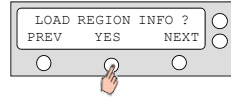

3. Press YES to load region information.

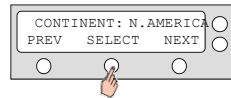

4. Select the continent¹⁾.
 PREV – Shows previous continent.
 SELECT – Set the displayed continent for editing.
 NEXT – Shows next continent.

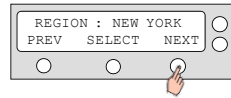

5. Select the region.
 PREV – Shows previous region.
 SELECT – Set the displayed region.
 NEXT – Shows next region.

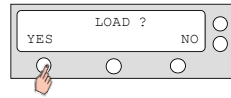

6. Press YES to load region info.
 Press NO to cancel and return to main setup mode.



7. Loading selected region info.

1) CONTINENT
 N. AMERICAN, S.AMERICAN, EUROPE, ASIA..
 2) REGION
 New York, Miami, UK, JAPAN..

Setting the factory default parameters

Initialize all of the antenna information to the factory set up.

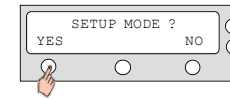

1. Press YES to enter setup mode.

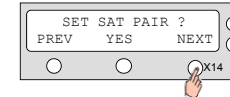

2. Press NEXT fourteen times to enter Default setting mode.

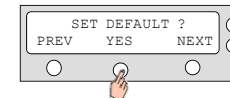

3. Press YES to set default parameters.

OPERATION USING PC Controller Program

Introduction

GUI Software of Intellian K4/K6 has been coded for the user to easily set up the antenna by using the user's personal computer. Using the GUI program enables the user to easily monitor and modify the information of antenna, satellite and GPS. Additionally, the detail diagnostic method of the antenna is provided by the GUI program.



WARNING

Before starting this GUI program, please install the USB to Serial Driver by inserting the supplied CD-ROM. (Refer to p.52)

To start this GUI program,

1. Connect one end of USB cable to the USB connector on the computer.
 2. Connect the other end of the USB cable (AB Type) to the "USB Interface" on the front of DACU.
- Ka USB Interface: To upgrade K4/K6 system or To operate GUI program
 - Ku USB Interface: To upgrade i4/i6 system or To operate GUI program
 - MIM USB Interface: To upgrade MIM system



↑ ↑ ↑
Ka (K4/K6) MIM Ku (i4/i6)

3. Execute GUI program by inserting the CD-ROM supplied into the CD-ROM drive of the computer.
4. After turning on the power of the DACU, if the blue status circle does not change to 'Search' or 'Tracking' from 'Initialize', then you have to change the "PC Interface" terminal of ACU for PC program use rather than GPS use.

Installation USB to Serial Driver

1. Execute RL2303 Driver Installer.exe by inserting the supplied CD-ROM into the CD-ROM drive of the computer.

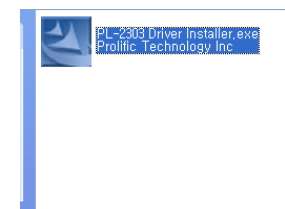

2. Press "NEXT" or "YES" button to complete the installation.

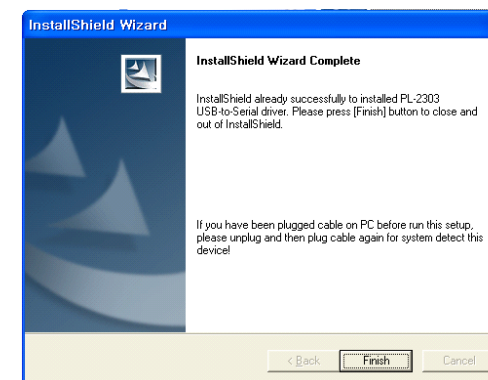

3. Execute the GUI Program in the same supplied CD-ROM to start the operation. (Refer to p.51)

Connects a PC with Ka (K4/K6) USB Interface:

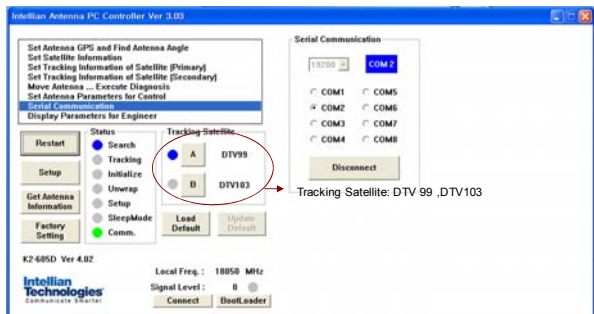

Connects a PC with Ku (i4/i6) USB Interface:

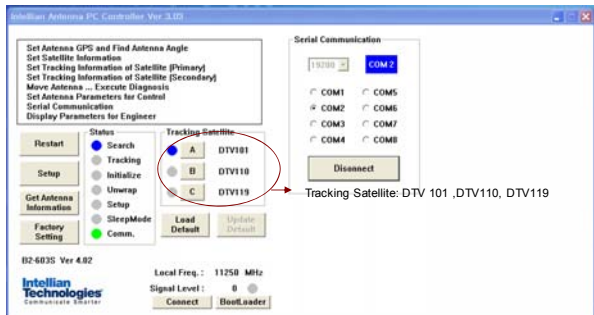

WARNING

The operation method is exactly same for both K4/K6 and i4/i6. The below instruction will be explained using the i4/i6 as example.

Program Initialing and Serial Port Setup

The communication between the ACU and antenna must be established as the first step in order to start setting your antenna.

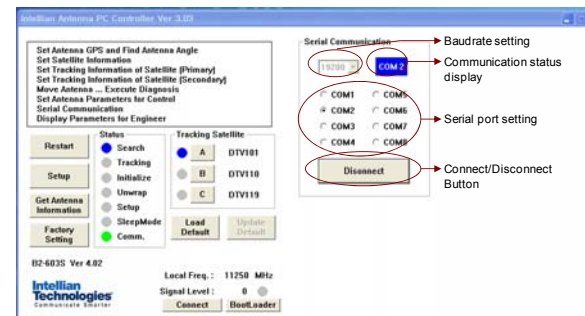

Command Button

- Baud Rate Setting – To display communication speed.
- Connection Status Display – To display communication port between ACU and PC.
- Serial Port Setting – To select serial port to be used.
- Connect/ Disconnect – To establish communication between PC and ACU.

Main Menu – Using Default Tri-sat Mode

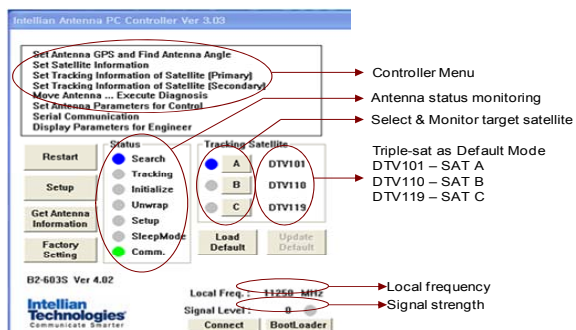

Antenna Status Monitoring

- Search – Antenna is searching for the selected satellite.
- Tracking – Antenna is tracking the selected satellite.
- Initialize – Antenna or the ACU is initializing.
- Unwrap – Antenna is unwrapping the wire.
- Setup – Antenna is in setup mode.
- Comm. – Antenna is possible communication.

Definition of Program Command Buttons

- Restart – To exit setup mode and restart antenna again.
- Setup – To enter the setup mode.
- Get Antenna Information – To indicate the information on display after receiving it input to the antenna.
- Factory Setting – To initialize all antenna information to the default as same as ex-factory status.
- Load Default – To show the up-to-date information input to PC program on display.
- Update Default – To update the antenna information by the up-to-date input to PC program.

Set Satellite Information

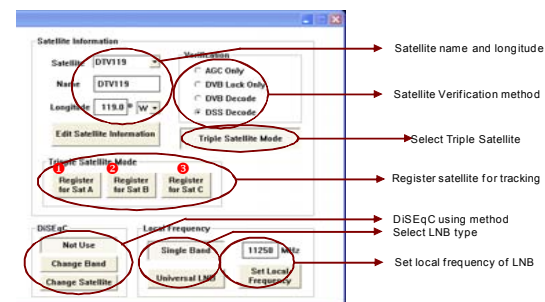

• Satellite Information

The name, longitude and confirmation method of the satellite is displayed when a satellite is selected in the list box. Push "Edit Satellite Information" button to update the information on modifying the value.

• DiSEqC

When the operation method of DiSEqC is selected to "Change Band", DiSEqC may be used for updating the local frequency and to "Change Satellite", for updating the target satellite.

Registration of target satellite

In case that Tri-sat Mode is selected and the DiSEqC is selected to "Not Use, only ① "Register for Sat A", ② "Register for Sat B" and ③ "Register for Sat C" may be registered. Pushing ① or ② or ③ button after selecting the satellite in the list box makes it possible to register A or B or C.

• Local Frequency

In case that DiSEqC is selected to "Change Band", be sure to push the "Universal LNB" button. In case that the DiSEqC is selected to "Not Use" or "Change Satellite", be sure to push "Single Band" button and key in into the Local Frequency, and then push " Set Local Frequency" button.

Command Button

- Edit Satellite Information – To modify the satellite information.
- Register for Sat A – To register a satellite to satellite A.
- Register for Sat B – To register a satellite to satellite B.
- Register for Sat C – To register a satellite to satellite C.
- Not Use – Do not use DiSEqC.
- Change Band – To use DiSEqC to change band.
- Change Satellite – To use DiSEqC to change the satellite.
- Single Band – Antenna in use of Single LNB.
- Universal Band – Antenna in use of universal LNB.
- Set Local Frequency – To select local frequency of LNB.

Load and Update Default Command Button

1) Load Default: Click "load default" button to select *.rif file according to your region.

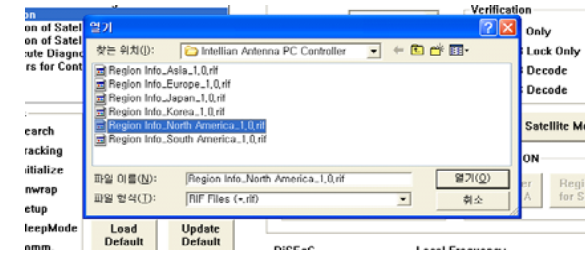

2) Update Default: Click "Update default" button to open update default Dialogue. Click "yes" button to update the system.

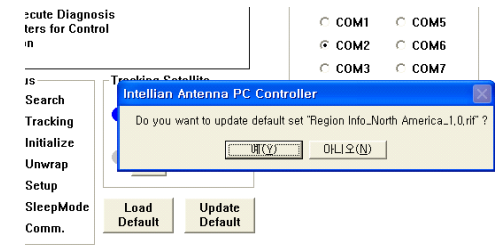

3) Click "confirm / yes" button to complete the update.

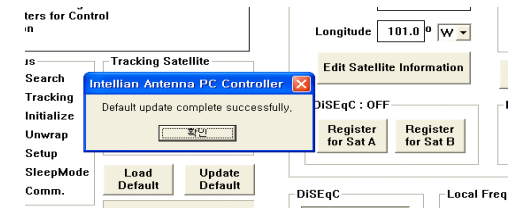

Controller menu

Set Antenna GPS and Find Antenna Angle

Antenna makes use of GPS information to search satellite quickly. The more precise the GPS information is, the quicker the antenna is able to search the satellite. The method to input information into GPS is to push "Set GPS" button after keying in the latitude and longitude information on "City GPS". Pushing "Add City" button stores the GPS information. By selecting the stored region in the list box, the GPS information of such region is displayed. The Intellian K4/K6 satellite TV antenna system utilizes GPS data to locate the satellite faster.

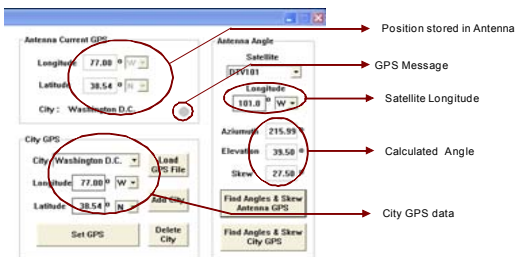

Command Buttons

- Load GPS Files – Reads in various city information from the GPS files.
- Add City – Adds the name of city and its GPS information to GPS files
- Delete City – Deletes the name of city and its GPS information from the GPS files.
- Set GPS – Inputs the indicated GPS information on display to antenna.
- Find Angles & Skew Antenna GPS – Finds the current antenna angles and Skew angle in relation to the longitude of satellite and GPS.
- Find Angles & Skew City GPS – Finds the current city angles and Skew angle in relation to the latitude of satellite and GPS.

Set Tracking Information of Satellite [Primary]

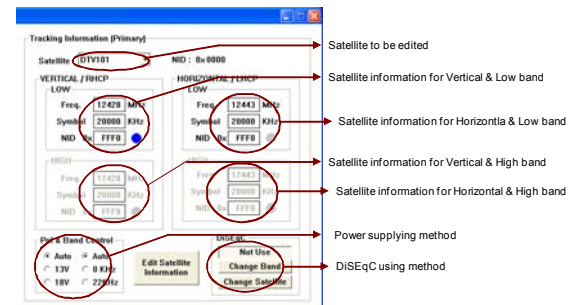

Command Button

- Edit Satellite Information – To change frequency information of the antenna
- Satellite Information – Satellite information consists of frequency, symbol and NID(Network ID) of a transponder in tracking satellite. There are four groups of satellite information. 'Vertical/RHCP' is applied when IRD supply 13V, and 'Horizontal/LHCP' is applied when IRD supply 18V. 'LOW' is applied when DiSEqC signal is not detected from IRD, 'HIGH' is applied when DiSEqC signal is detected from IRD. If you select 'Not Use' or 'Change Satellite', two 'HIGH' groups are inactivated. If you select
- Change Band, two 'High' groups are activated and you can modify satellite information which is applied when DiSEqC signal is detected from IRD. After modifying information, press 'Edit Satellite Information' button, then new information is updated in the antenna.
- Pol & Band Control – The power controls 13V, Vertical (RHCP) and 18V, Horizontal (LHCP) bands. The Band controls High and Low bands. (AUTO RRECOMMEDED)

AUTO & AUTO : 13V and 18V supplied to LNB without regard to IRD.
 AUTO & 0KHz : Low band supplied to LNB without regard to IRD
 AUTO & 22KHz : High band supplied to LNB without regard to IRD

13V & AUTO : 13V supplied to LNB without regard to IRD.
 13V & 0KHz : 13V & Low band supplied to LNB without regard to IRD.
 13V & 22KHz : 13V & High band supplied to LNB without regard to IRD.

18V & AUTO :18V supplied to LNB without regard to IRD.
 18V & 0KHz : 18V & Low band supplied to LNB without regard to IRD
 18V & 22KHz :18V & High band supplied to LNB without regard to IRD.

Set Tracking Information of Satellite [Secondary]

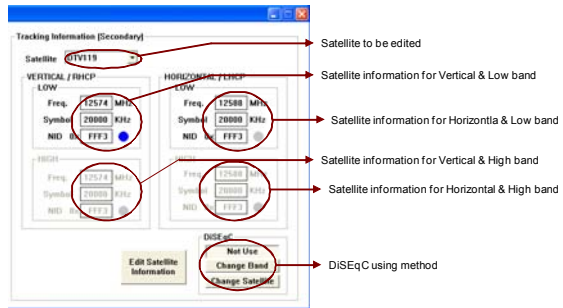

Command Button

- Edit Satellite Information – To change frequency information of the antenna.

Move Antenna and Execute Antenna Diagnosis

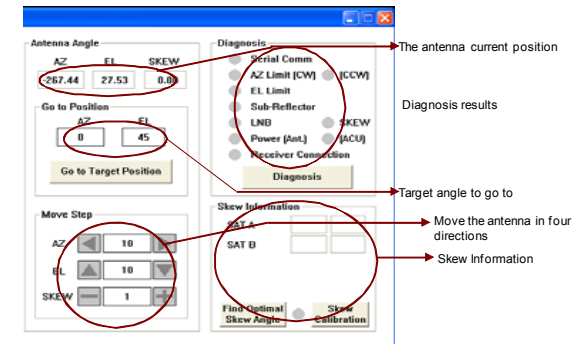

- Angle of Antenna
 Two kinds of antenna movement is available. One is to move to the target position and the other is to move by certain amount of angle. The current position(angle) of the antenna is displayed as "Current" and to move to the target position, push "Go to target Position" button after keying in desired angle into "Target". To move to a certain amount of angle only, move antenna to direction of up or down, and CW or CCW by using ▲ ▼ ◀ ▶ buttons after keying in the desired angle into the AZ and EL in the "Mover Step" box. Rotate LNB to direct the skew angle by using ⏪ ⏩ button.
- Self-Diagnosis
 If "Diagnosis" button is pressed to carry out self- diagnosis of antenna, it displays the result of self-diagnosis after carrying it out. Blue circle means the antenna is normal; red represents abnormal and green represents the antenna is under diagnosis.

Command Button

- Go to Target Position – To move the antenna to the present position.
- Diagnosis – To diagnose the antenna (BLUE – Passed, RED – Failed, GREEN – Under diagnosis)

Set Antenna Parameters for Control

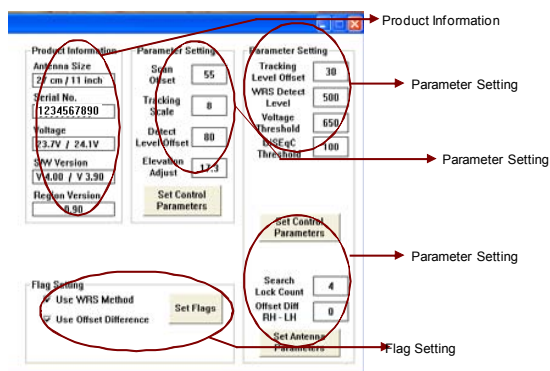

Command Buttons

Set Control Parameter – To register parameters values.

Set Flags – To set flag setting for WRS Method or Offset Difference.

Product Information – Antenna dish size, Serial NO, Voltage for antenna and ACU, Software version for ACU and Control.

Parameter Setting – To set antenna parameter values.

SCAN OFFSET : The actual angle between the marked point on sub-reflector and the datum.

TRACK SCALE : To control the tracking speed while antenna is tracking the satellite.

High track scale value resulting in high tracking speed.

DETECT LEVEL : The basic single detection level.

TRACKING LEVEL : The basic signal tracking level

EL ADJUST : The mechanical tolerance compensation of elevation limit.

WRS LEVEL : The basic WRS detection level.

VOLTAGE THRESHOLD : The value to identify Vertical/Horizontal or RHCP/LHCP

DISEQC THRESHOLD : The value to identify 22KHz tone.

OFFSET DIFFERENCE : The difference value between RHCP/LHCP and SCAN OFFSET .

USE WRS : To apply WRS while antenna is searching for satellite.

USE OFFSET DIFFERENCE : To apply Offset Difference.

Troubleshooting

Symptom	Possible cause*							
	1	2	3	4	5	6	7	8
Antenna not functioning	X							
No picture on TV set			X					X
Intermittent picture for short intervals		X	X	X	X	X		X
System works at the dock but not underway		X						
System will not find satellite		X	X	X	X	X	X	X
'Snowy' television picture				X				

Note : * for an explanation of possible cause and their remedies refer to the following paragraphs

1. Blown fuse, low power or wiring

Check that the in-line quick blow fuse (if fitted) has not blown or the circuit breaker has not tripped. Replace fuse with one of the same type and rating. If you have extended the power cable from the antenna unit, check that there is no power loss. Check the system wiring and connections.

2. Satellite signal blocked

Satellite signals can be blocked or degraded by buildings, other boats or equipment on your boat. Check to see if the antenna has a clear view of the sky.

3. Outside satellite coverage zone

Your system will provide excellent reception within the antenna coverage area for your satellite television service. However, signal quality may degrade as you approach the edges of this zone.

4. Radar interference

The energy levels radiated by radar units can overload the antenna a front-end circuits. Make sure that your antenna is installed as described in page 8; 'Selection of Installation Site'.

5. Incorrect or loose RF connectors

As part of the regular maintenance recommended by Intellian Technologies, Inc., all connections should be checked to ensure that they have not become loose. A loose RF connector can reduce signal quality.

6. Multi-switch interference

If you have multiple satellite receiver (IRD) connected to your system, make sure that you are using an active not passive multi-switch.

7. Satellite receiver (IRD) troubleshooting

Your satellite receiver (IRD) may be the cause of less than ideal operation.

- 1) Check the satellite receiver's (IRD's) configuration to ensure that it is programmed for the area in which you are operation.
- 2) Unplug the satellite receiver (IRD) from the power supply for 1 second. Reconnect and allow the system to initialize.

8. LNB fault

If you have an LNB fault, it may require replacing. Contact your local dealer, national distributor or Intellian Technologies, Inc. product support for further assistance.

Preparation for Transportation

This is to describe how to fix the antenna internally for transportation, and the following procedures to fix antenna shall be strictly observed to protect it from being damaged during transportation.

1. Refer to the drawing.
2. Rotate antenna left and right slowly till the limit switch is pressed.



WARNING Don't rotate it quickly, or you may damage the antenna limit system.

3. Turn the antenna by 360° to the reverse direction.
4. Insert the sponge in both sides of the dish to fix the pedestal in position with the bottom radome.
5. Cover upper part of Radome being careful for it's not touching the reflector, and then assemble upper part of radome.
6. Pack Intellian K4/K6 into the original package box.

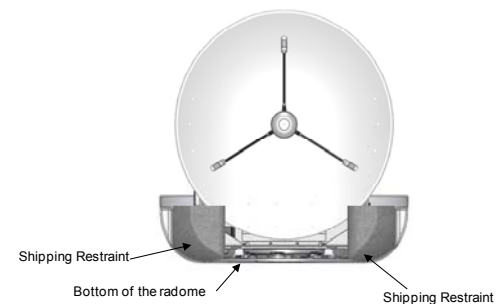

Warranty

This product is guaranteed by Intellian Technologies Inc., against defect due to faulty workmanship or materials and this guarantee covers for 2-year parts and 1-year labor for labor performed at Intellian Technologies, Inc. service center from the date of purchase of the product.

You are requested to present a copy of the purchase receipt issued by Intellian Technologies, Inc. that presents the date of purchase for after sales service under warranty. In case of failure to present the date of purchase, the warranty period is to be calculated to 30 days after the manufacturing production date.

If you discover a defect, Intellian Technologies, Inc. will, at its option, repair, replace or refund the purchase price of the product at no charge to you, provided you return it during the warranty period, transportation charges prepaid, to the factory direct. Please attach your name, address, telephone number, a description of the problem, and a copy of the bill of sale or sales receipt as proof of date of original retail purchase, to each product returned to warranty service. Alternatively, you may bring the product to an Authorized Intellian Technologies, Inc. dealer/distributor for repair.

This Limited Warranty does not apply if the product has been damaged by accident, abuse, misuse or misapplication or has been modified without the written permission of Intellian Technologies, Inc.; if any Intellian Technologies, Inc. serial number has been removed or defaced; or if any factory-sealed part of the system has been opened without authorization

Appendix: K6 Technical specification

General

Approvals	
CE – conforms to	EU Directive 89/336/EEC
FCC – verified to	CFR47:Part 15
Dimensions	
Satellite antenna unit	70cm (27.5") x 72cm(28.3")
Antenna dish diameter	60cm(23.6")
Dual Antenna control unit	43cm(16.9")x26.58cm(10.5")x4.37cm(1.7")
Weight	
Satellite antenna unit	20kg (44 lbs)
Dual Antenna control unit	4kg (8.8 lbs)
Environmental	
Operating temperature range	-15°C to +55°C (+5°F to +131°F)
Storage temperature range	-25°C to +70°C (-13°F to +158°F)
Humidity limit	95% R.H
Operating voltage	90 ~ 260 V AC

Antenna system performance

Frequency	Ka-band (18.3~20.2GHz)
Azimuth range	680°
Elevation range	+5° ~ +90°
Ship's motion	Roll ±25° Pitch ±15°
Roll and pitch response rate	45° per second
Turn rate	45° per second

Appendix: K4 Technical specification

General

Approvals	
CE – conforms to	EU Directive 89/336/EEC
FCC – verified to	CFR47:Part 15
Dimensions	
Satellite antenna unit	50cm(19.7") x 54cm(21.2")
Antenna dish diameter	45cm(17.7")
Antenna control unit	17.8cm(7")x21.6cm(8.5")x5.38cm(2.1")
Weight	
Satellite antenna unit	11.6kg (21.5 lbs)
Antenna control unit	1.2kg (2.6 lbs)
Environmental	
Operating temperature range	-15°C to + 55°C
Storage temperature range	-25°C to + 70°C
Humidity limit	95% R.H
Operating voltage	90 ~ 260 V AC

Antenna system performance

Frequency	Ka-band (18.3~20.2GHz)
Azimuth range	680°
Elevation range	0° ~ +90°
Ship's motion	Roll ±25° Pitch ±15°
Roll and pitch response rate	50° / second
Turn rate	50° / second



Intellian Technologies, Inc.

HQ Dongik Building 7th Fl.,
98 Nonhyun-Dong, Gangnam-gu,
Seoul 135-010, Korea
Tel : +82-2-515-4923
Fax: +82-2-545-4903

Factory SK Ventium 104-501,
522 Dangeong-Dong, Gunpo-Si,
Kyunggi-Do 435-776, Korea
Tel : +82-31-436-1488
Fax: +82-31-436-1489

R&D Center SK Ventium 104-601,
522 Dangeong-Dong, Gunpo-Si,
Kyunggi-Do 435-776, Korea
Tel : +82-31-436-2280
Fax: +82-31-436-2284

Intellian Technologies USA, Inc.

9261 Irvine Blvd.
Irvine, CA 92618 USA
Tel : +1-949-916-4411
Fax: +1-949-271-4183

E-Mail: customersupport@Intelliantech.com

Homepage: <http://www.Intelliantech.com>