

# **NORTHSTAR**

**TECHNOLOGIES**



## ***6000i* NETWORKED NAVIGATION SYSTEM INSTALLATION MANUAL**

Revision G  
Part Number GM6KIM

**Northstar**  
a unit of Brunswick New Technologies Marine Electronics  
30 Sudbury Road  
Acton, Massachusetts 01720

**www.NorthstarNav.com**  
Service: 978/897-6600  
Sales: 800/628-4487



# Contents

<b>SECTION ONE: Introducing the 6000i</b>	<b>1</b>
Checking the 6000i package	1
<b>SECTION TWO: Installing and wiring the 6000i</b>	<b>5</b>
Bench-testing the 6000i	5
Mounting the 6000i	5
Wiring the 6000i	8
<b>SECTION THREE: Installing and wiring the antenna</b>	<b>13</b>
Choosing the best mounting location	13
Mounting and wiring the AN150-P antenna	15
<b>SECTION FOUR: Networking the Northstar 6000i</b>	<b>17</b>
Restrictions on networking	18
Connecting a network of two devices	19
Connecting a network of more than devices	19
Networking setup	17
<b>SECTION FIVE: Checking out the system</b>	<b>27</b>
Turning the 6000i on and off	27
Checking satellite status	27
Checking DGPS status	28
Installation-test checklist	28
<b>SECTION SIX: Interfacing the 6000i system</b>	<b>31</b>
The NMEA connector	32
Configuring the RS-232 port	38
Using the Aux Port	39
Connecting the 6000i to a remote display	43
Connecting the 6000i to a video camera	43
<b>SECTION SEVEN: Troubleshooting and servicing the 6000i system</b>	<b>45</b>
Troubleshooting installation problems	45
Getting technical support	47
<b>APPENDIX A: 6000i system technical specifications</b>	<b>51</b>



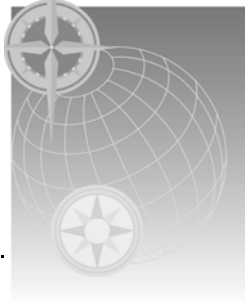

# SECTION ONE: Introducing the 6000i

## Checking the 6000i package

The Northstar 6000i is a networked color GPS navigation family that you can connect to a wide variety of optional equipment, including the Northstar 491 echo sounder, Northstar radar, and VGA displays. Other optional interfaces include any NTSC- or PAL-compatible video sources, such as a video camera, TV, DVD, or VCR. For installation instructions for the Northstar 491 or Northstar radar, see the *Northstar 491 Installation Manual* (P/N GM495) or the *Northstar Radar Installation Manual* (P/N GMKRadIM or GMRad2KIM).

**Table 1: 6000i parts list**

Qty	Part name	Part number				
		6.4" unit	8.4" unit	10.4" unit	12" Unit	15" unit
1	6000i unit	6K6	6K8	6K10	6K12	6K15
1	Flush-mount hardware kit	6K6FM-A	6K8FM-A	6K10FM-A	6K12FM-A	6K15FM-A
1	Flush-mount gasket	–	–	–	HG420	HG412
1	Flush-Mounting Template	GT6K6	GT6K8	GT6K10	GT6K12	GT15
1	Yoke-mount kit	6K6YM-A	6K8YM-A	6K10YM-A	–	–
1	Sunshield	XP793	XP784	XP789	XP821	XP817
1	WAAS/GPS antenna and cable	AN150-P (AN-156-P Optional)				
1	TNC connector for antenna cable	–	–	–	–	KC285
1	10-foot power cable with 7-amp fuse	WA535-B				
1	10-foot NMEA interface cable	WA215				
1	Connector dust cover	KC398				
1	Northstar 6000i Installation Manual	GM6KIM				
1	Northstar 6000i Operator's Manual	GM6KUM				
1	Quick Pocket Reference	–	–	–	GM6K12QR	–
1	Owner registration card	GD671				
1	Limited Warranty Statement	GD683				
1	Navionics slip sheet	GM988				
1	Parts kit (see next page)	6K-PK				15-PK

To connect multiple units using Northstar's N2 technology, Ethernet cables must be purchased separately (see "SECTION FOUR: Networking the Northstar 6000i" starting on page 17).

**Table 2: Parts Kit contents for 6.4", 8.4", and 10.4" 6000i (P/N 6K-PK)**

Qty	Part name	Part number
1	Spare fuse (7A fast-blow 5 x 20mm)	FF211
4	Hex nut, 6-32, for flush-mounting	HN300
4	Threaded stud, 6-32, for flush mounting	HS610
4	Lockwasher, # 6, for flush mounting	HW300
4	Flat washer, #6, for flush mounting	HW405
1	TNC connector for antenna cable	KC285

**Table 3: Parts Kit contents for 12-inch 6000i (P/N 6K12-PK)**

Qty	Part name	Part number
1	Spare fuse (7A fast-blow 5 x 20mm)	FF211
12	Hex nut, 8-32, for flush-mounting	HN421
12	Threaded stud, 8-32 x 2 1/4, for flush mounting	HS605
12	Lockwasher, #8, for flush mounting	HW400
12	Flat washer, #8, for flush mounting	HW405
1	TNC connector for antenna cable	KC285

**Table 4: Parts Kit contents for 15-inch 6000i (P/N 15-PK)**

Qty	Part name	Part number
1	Spare fuse (7A fast-blow 5 x 20mm)	FF211
12	Hex nut, 8-32, for flush-mounting	HN421
12	Threaded stud, 8-32 x 2 1/4, for flush mounting	HS605
12	Lockwasher, #8, for flush mounting	HW400
12	Flat washer, #8, for flush mounting	HW405
1	TNC connector for antenna cable	KC285

**Table 5: 6000i Optional equipment**

<b>Part name</b>	<b>Part number</b>
Ethernet cables	See Section 4
Remote control and batteries	6KRMC-A
Spare batteries for remote control	BL134
Additional antenna cable	WC255 or WC263
Northstar Echosounder	
Northstar Radar	







## SECTION TWO: Installing and wiring the 6000i

<p><b>WARNING!</b></p> 	<p><i>Before starting the installation, be sure to turn electrical power off. If power is left on or turned on during the installation, fire, electrical shock, or other serious injury may occur.</i></p> <p><i>Be sure that the voltage of the power supply is compatible with the 6000i's voltage rating of 10 to 36 volts DC. Connecting to the wrong power supply can cause fire or damage to the equipment.</i></p> <p><i>Be sure to ground the equipment to prevent electrical shock and mutual interference.</i></p> <p><i>Be sure to use a 7-amp fast-blow fuse in the supplied power cable. Using the wrong fuse can cause fire or damage to the 6000i.</i></p>
----------------------------------------------------------------------------------------------------------	---------------------------------------------------------------------------------------------------------------------------------------------------------------------------------------------------------------------------------------------------------------------------------------------------------------------------------------------------------------------------------------------------------------------------------------------------------------------------------------------------------------------------------------------------------------------------------------------------------------------------------------------------------------------------

### Bench-testing the 6000i

---

Northstar recommends bench-testing the 6000i with a GPS antenna before installing it onto the vessel. Bench testing ensures that the equipment is fully operational, and lets the unit collect the current almanac and ephemeris data and a local position fix, which results in less on-board installation time.

### Mounting the 6000i

---

<p><b>CAUTION!</b></p> 	<p><i>Proper installation of the Northstar 6000i is critical to accurately receive and effectively use GPS/WAAS signals under a wide variety of weather conditions.</i></p> <p><i>Keep the following safe compass distance from the 6000i: 1.0m standard, 0.8m steering.</i></p>
------------------------------------------------------------------------------------------------------------	----------------------------------------------------------------------------------------------------------------------------------------------------------------------------------------------------------------------------------------------------------------------------------

### Choosing the best mounting location

Choose the mounting location carefully before you drill or cut. The 6000i should be installed in an accessible, dry location where the operator can easily use the controls and clearly see the display screen. Be sure to leave a direct path for all of the cables. The display screen is high-contrast and anti-reflective, and is viewable in direct sunlight, but for best results, install the 6000i out of direct sunlight. The chosen location should have minimal glare from windows or bright objects. If the 6000i is yoke-mounted low, tilt the unit back for best viewing contrast.

## Mounting dimensions

Figures 1 – 5 show the overall unit dimensions.

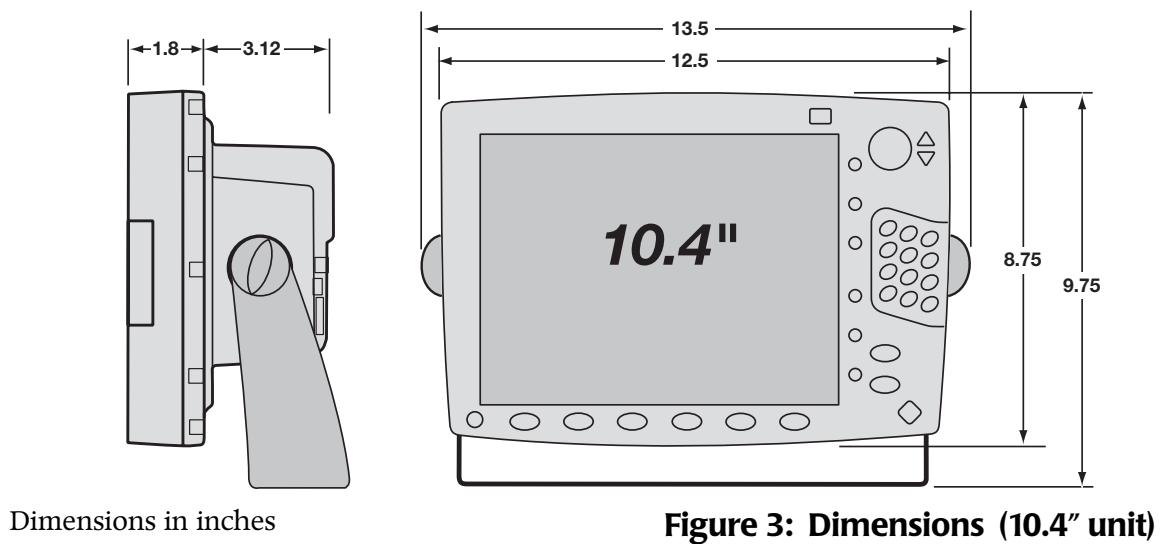
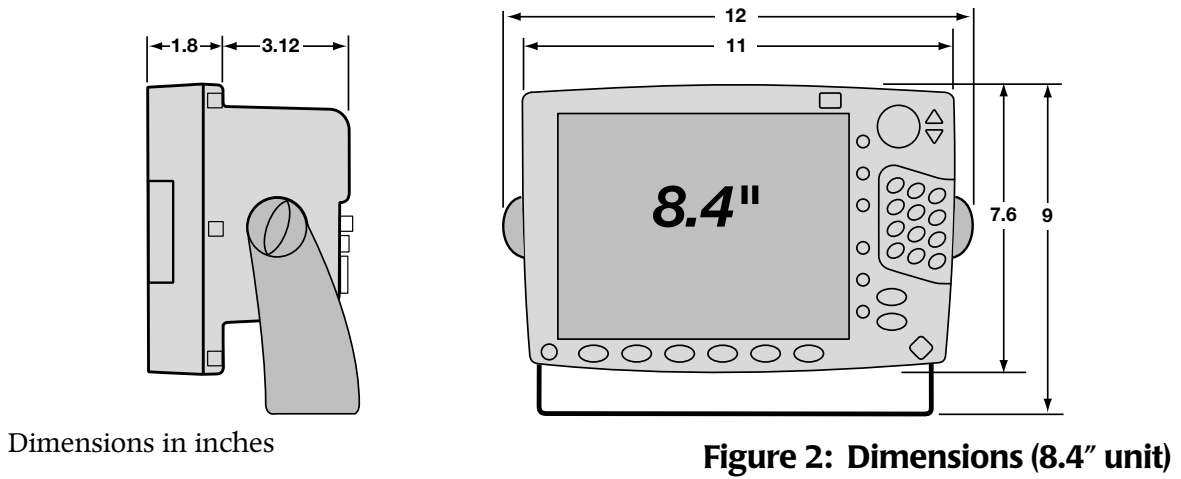
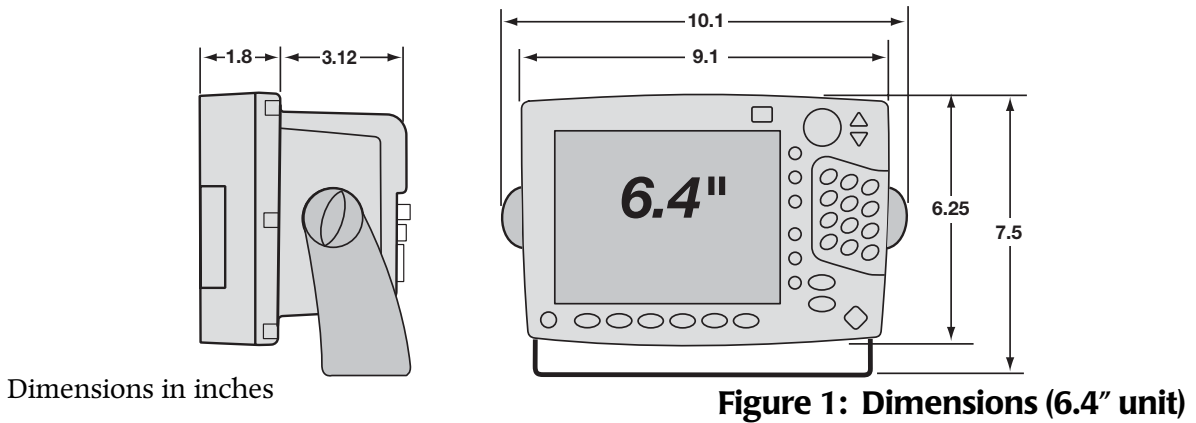

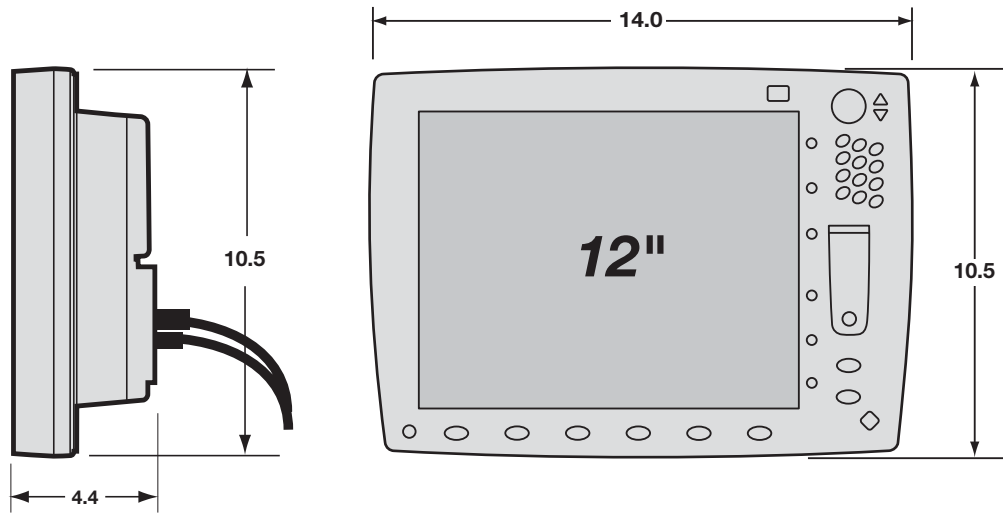

Dimensions in inches

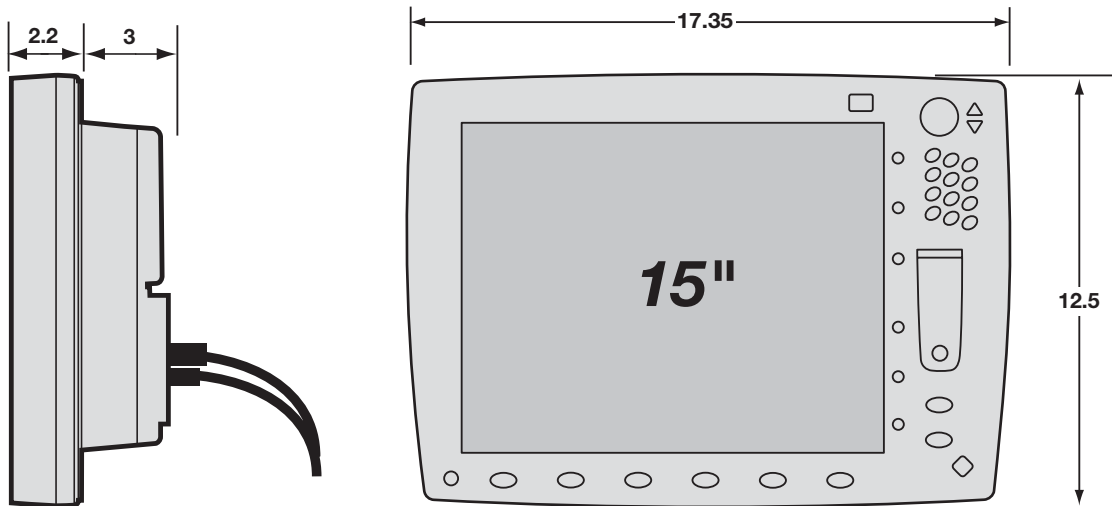
**Figure 4: Dimensions (12" unit)**  
(Flush-mount only)

Dimensions in inches

**Figure 5: Dimensions (15" unit)**  
(Flush-mount only)

## Flush-mounting

When flush mounting, leave sufficient clearance space behind the unit for all of the cables and connectors. Clearance is also required on the right side of the unit for opening the chart cartridge door (not necessary for the 12" or 15" units). Flush mounting requires good ventilation behind the mounting panel. Poor ventilation may cause the 6000i to overheat, which, in turn, will cause the screen brightness to dim. For overall width and height requirements, see the *Northstar 6000i*

*Flush-Mounting Template*, which you can use to drill the mounting holes and cut the mounting panel in the exact recommended locations.

<b>CAUTION!</b> 	<i>When flush mounting, be sure to mount the 6000i on a flat surface. Mounting on a curved surface can result in water leaks. Do not overtighten the mounting screws; you may damage the case and compromise its waterproof seal. This type of physical damage will void the warranty.</i>
------------------------------------------------------------------------------------------------------	--------------------------------------------------------------------------------------------------------------------------------------------------------------------------------------------------------------------------------------------------------------------------------------------

Use the supplied flush-mount template to cut the hole for the *6000i*, and use the supplied gasket between the *6000i* and the instrument panel to help seal against water penetration. The use of **anti-seize compound** on the flush-mount studs and nuts is recommended.

The parts kit contains the appropriate number of threaded studs, flat washers, lock washers, and hex nuts for flush mounting.

## Yoke-mounting

For recommended mounting clearances, see Figures 1 – 3 on the previous pages. Leave additional clearance for opening the cartridge door on the right side of the unit. The 12- inch and 15-inch models are designed for flush-mounting only.

When yoke-mounting, the four plastic “poker chips” are inserted into the holes in the unit and the yoke. It may be helpful to apply a dab of RTV or other adhesive to keep them in place during installation, especially if the unit will be removed and replaced frequently.

## Wiring the *6000i*

---

### Avoiding cable wiring shortcuts

Most installation problems are caused by shortcuts taken with system cables. When wiring the *6000i*, follow the guidelines below.

#### DON'T DO THIS!

- Don't make sharp bends in the cables
- Don't run cables in a way that allows water to flow down into the connectors

#### DO THIS!

- Do make drip and service loops
- Do tie-wrap all cables to keep them secure
- If cables are shortened, lengthened, or re-terminated, do seal and protect all wiring connections
- Do leave room at the back to install and remove cables

## The interface connectors

Interface connectors are shown in Figure 6: "Interface connectors," below. The functions of these connectors are described in Table 6. Interfacing is described in detail in Section Six, beginning on page 31.

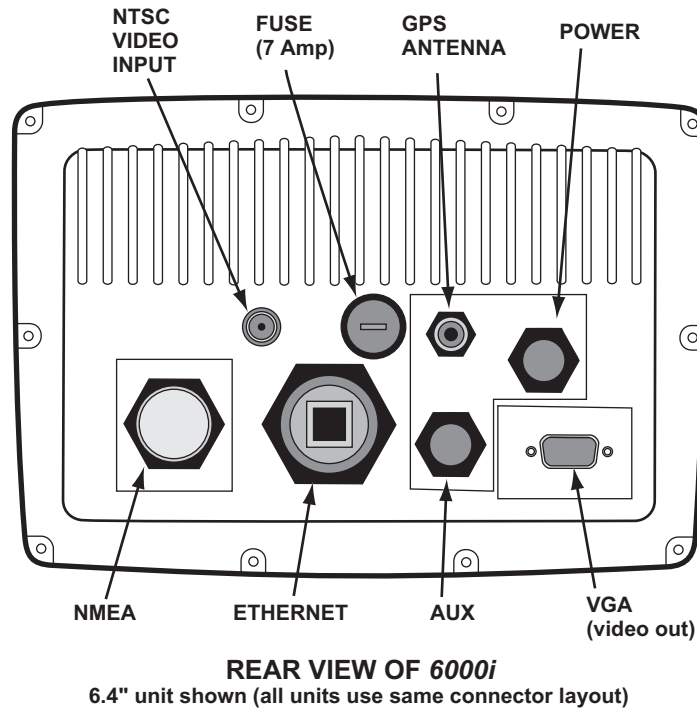

**Figure 6: Interface connectors**

**Table 6: Interface connector functions**

Connector name	Connector function(s)	Connects to...
NMEA (18-pin connector)	NMEA Port 1 input/output	NMEA devices: autopilot, heading sensor, etc.
	NMEA Port 2 input/output	Same as NMEA Port 1, or Northstar radar
	RS-232 Port	SC-104, NMEA devices, or remote power control
	Honk alarm/200 pppm	Remote honk alarm, or speed indicator
Ethernet (RJ-45)	N2 Networking	Another 6000i or other N2-compatible device (N2 is Northstar's proprietary format)
GPS (TNC coaxial 50 Ohm)	GPS antenna input	AN150-P GPS antenna

**Table 6: Interface connector functions (continued)**

Connector name	Connector function(s)	Connects to...
AUX (6-pin connector)	RS-422/NMEA input/output	Northstar 491 echo sounder, or older Northstar units for database transfer
POWER (3-pin connector)	Power input	10 to 36 VDC, 30 watts
VGA (15-pin D connector)	Video output	Remote display
NTSC VIDEO INPUT (BNC coaxial 75 Ohm)	Video input	Any NTSC-compatible video source

## Electrical power requirements

The 6000i is a negative-ground system that's reverse-polarity protected. Power requirement is 10 VDC minimum to 36 VDC maximum, using at least 16-gauge connecting wire.

<b>CAUTION!</b> 	<i>To protect the power wiring, Northstar strongly recommends that you connect the 6000i to a circuit breaker or 7-amp fuse located at the power source (battery or switch panel).</i>
------------------------------------------------------------------------------------------------------	----------------------------------------------------------------------------------------------------------------------------------------------------------------------------------------

## Connecting the 6000i to ship's power

The 6000i is shipped with a 10-foot power cable that you can lengthen to a **maximum** of 25 feet:

- for a cable length up to 15 feet, use 16-gauge wire or heavier
- for a cable length from 15 to 25 feet, use 14-gauge wire or heavier

If you lengthen the power cable, use an external fuse at the battery end as an added safety precaution. **The fuse size should be chosen to be appropriate for the size of the smallest conductor in the circuit.** See the NMEA or American Boating and Yachting Counsel specifications to find the correct fuse for your wiring.

For the best protection from noise, connect the power wiring directly to the battery or dedicated electronics bus. The green ground wire should be connected directly to ship's ground. The power cable has an inline fuse to protect the vessel's wiring, and prevent electrical fires and damage to the unit. If you shorten or lengthen this cable, be sure to keep the inline fuse intact (or provide circuit breaker protection).

Spare in-line fuses are not supplied with the unit and should be purchased locally to avoid loss of function.

Connect the wires in the power cable as follows.

- red → positive (+)
- black → negative (-)
- green → ship's ground

**NOTE:**

*Grounding the 6000i to the vessel usually reduces interference. Without an earth grounding, performance may be reduced. Secure the green wire to the vessel's nearest grounding point. If a noise-free earth grounding point isn't available, cap and insulate the green wire—it shouldn't be used when an earth ground isn't available, or with systems using "floating" grounds.*







## SECTION THREE: Installing and wiring the antenna

### Choosing the best mounting location

---

**Before you drill or cut**, choose a mounting location that meets the following criteria. The antenna should be mounted:

- where there's enough mounting clearance to easily connect the cable
- low on the vessel, and near the center, since motion caused by the vessel's roll, pitch and yaw can degrade speed-over-ground (SOG) and course-over-ground (COG) readings
- away from the radiation plane of any INMARSAT or radar antennas, and away from any other high-power transmitting antennas (see Figure 8 on page 14)
- high enough to provide an unblocked view of the sky in all directions, minimizing or eliminating any obstructions that block the antenna's view of the sky (the system can use satellites down to the horizon)
- away from masts or objects that could "shadow" the antenna

To avoid mutual interference among different antennas on the vessel, see the recommendations in Figure 8 below. This figure shows the minimum distances that should separate GPS/WAAS antennas from other antennas and physical mounting surfaces. Normally, these guidelines produce a relatively trouble-free installation; however, since every installation is unique, you may want to adjust these distances to the particular equipment.

Before permanently installing the antenna, try temporarily installing it and using the *6000i* to see if the location works well.

Do not open the antenna (other than removing the top to install). There aren't any serviceable parts inside. Unauthorized tampering will automatically void the warranty.

### Antenna cable lengths

You *must* observe the min/max cable length requirements for the GPS antenna shown in Table 7. Don't lengthen or shorten the cable beyond these limits. The AN150-P antenna is normally shipped with the *6000i*. If you need to use a longer cable than can be used with that antenna, contact the factory about substituting a higher-gain AN-156-P antenna.

**Table 7: GPS antenna cable lengths**

Antenna	Minimum length	Maximum length
<b>AN150-P (standard)</b>	20 feet	50 feet
<b>AN156-P (optional)</b>	50 feet	100 feet



**Figure 7: Northstar AN150-P antenna**

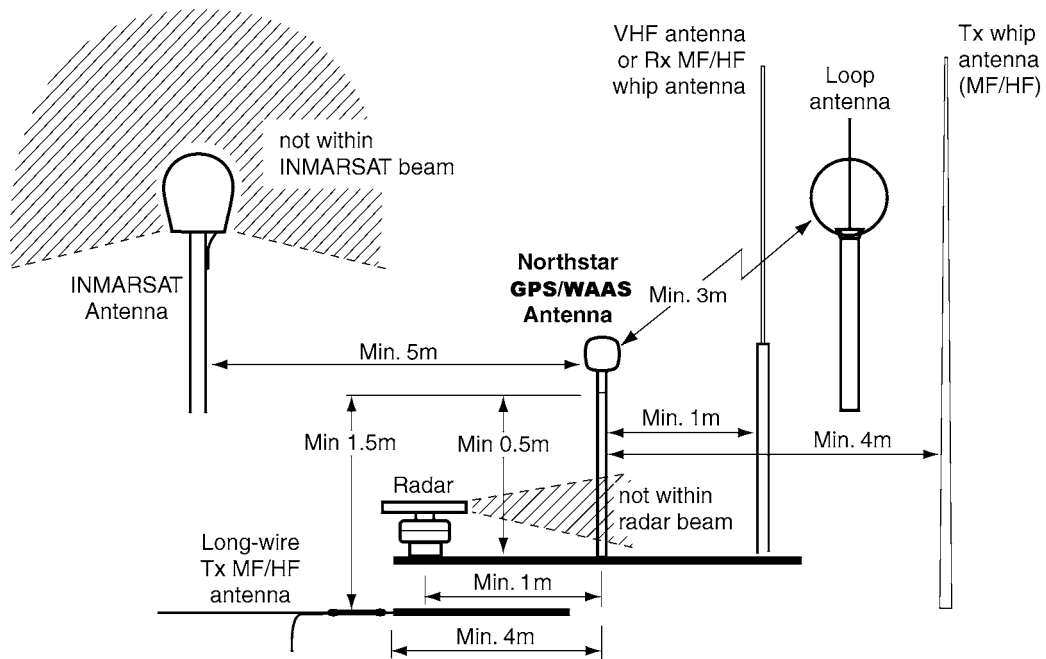

**Figure 8: Recommended separation distances between antennas**

## Mounting and wiring the AN150-P antenna

The AN150-P is mounted onto a standard antenna mount. To complete this installation, you'll also need a standard antenna mount and extension mast and/or adapter with a side exit for the coaxial cable. A 50-foot length of RG-59 coaxial cable is supplied with the AN150-P antenna.

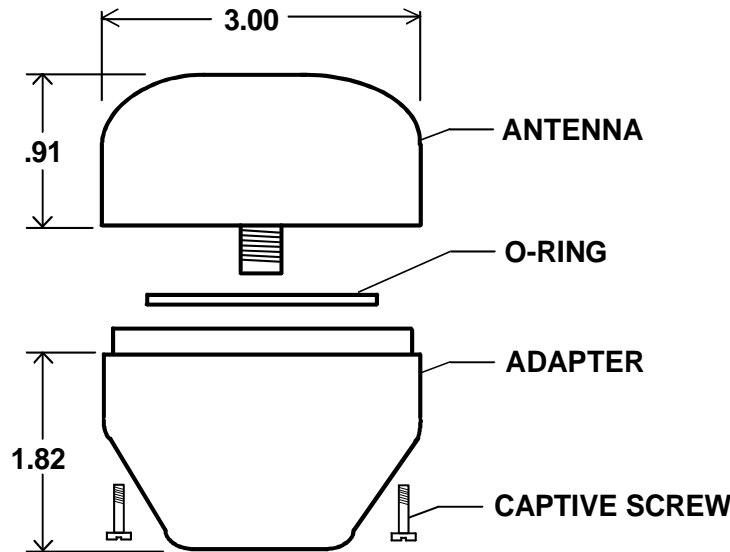

**Figure 9: AN150-P antenna**

Tools needed:

- flat-bladed screwdriver
- knife blade
- Amphenol crimp tools

One TNC connector is pre-attached to the antenna-end of the RG-59 coaxial cable. Connection to the antenna itself involves the following steps:

1. Remove the antenna base from the top by loosening the four captive screws in the base.
2. Screw the base onto the top of the antenna mount (standard 1"-14 marine thread).
3. Feed the open end of the supplied coax cable down through the antenna base and through the hollow core of the antenna mount.
4. Affix the TNC connector-end of the coax to the mating connector inside the upper half of the GPS antenna. Be sure to tighten it securely, as vibration can loosen the connection over time. In addition, protect the coax-to-antenna connection with liquid electrical tape or self-vulcanizing electrical tape.
5. Align the upper half of the antenna with the bottom half and tighten the four screws. Be careful not to over-tighten the screws, as this may deform the watertight seal between the two antenna halves.

*Next, we'll install the male TNC connector.*

- Strip cable jacket to the following dimensions (in inches), as illustrated in Figure 10: "Stripping the coax cable jacket," below:  $a=0.57$ ,  $b=0.34$ ,  $c=0.14$ ,  $d=0.43$ . Do not nick the center conductor.

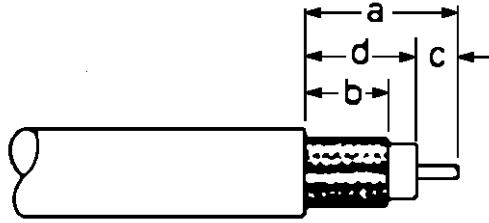

**Figure 10: Stripping the coax cable jacket**

- See Figure 11: "Flared cable braid," below: Slide outer ferrule on as shown. Slightly flare the end of cable braid, as shown, to facilitate insertion into inner ferrule.



**Figure 11: Flared cable braid**

- Place center contact onto center conductor so that it butts against the cable dielectric. Crimp the contact in place using Amphenol tool handle #227-944 and Cavity B of Die Set 227-980-3.
- Install cable assembly into body assembly so inner ferrule slides over dielectric and under braid. Push cable assembly forward until contact seats in insulator. Slide outer ferrule over braid and up against connector body. Crimp outer ferrule using Cavity A of tools specified above. The connector ferrule-to-cable junction can be sealed and protected using adhesive-lined heat shrink.

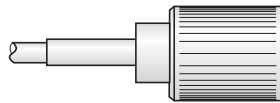

**Figure 12: Completed TNC connector**

- Connect the antenna to the female TNC connection at the back of the unit.



## SECTION FOUR: Networking the Northstar 6000i

**NOTE: This entire section can be ignored for a simple installation with no networking involved, or for an installation that involves only traditional NMEA connections.**

The 6000i uses Northstar's new N2 networking technology. N2 technology is based on the Ethernet standard, conforming to the IEEE 802.3u 100Base-TX specification (also referred to as "Fast Ethernet.") A single cable with standard connectors simply plugs into each unit. Using N2 technology, multiple 6000i displays can automatically:

- Share charts between units. Charts from a cartridge inserted in the master unit are available on all networked units. Charts from a cartridge inserted into a slave unit are available on that unit.
- Share all waypoints and routes between units. Any changes made to the waypoints and routes in one unit are copied to the other units with no action by the user. Waypoint and route navigation control is available from all networked units.
- Share echosounder data from the Northstar 491 between units. The 491 can be controlled from any display unit.
- Share radar data from Northstar radar between units. The radar can be controlled from any 6000i display. The radar overlay function can be used on only one display at a time.

NTSC video is not shared over the network because of bandwidth limitations. A separate coaxial video cable must be run to each display unit that will display video.

Waypoint and route transfer between a 6000i and a Northstar 951, 952, 957 or 958 is accomplished using the **AUX** port as described in "Using the Aux Port" starting on page 39.

Waterproof Ethernet cables can be ordered from Northstar in a variety of lengths. Ethernet cables are not included with the unit, since types and lengths vary by installation.

### Networking setup

---

In any N2 networked installation, one and only one 6000i must be designated as the master unit. All others are designated as slaves. **All 6000i units are shipped from the factory configured as masters, and any units that will be used as slaves must be reconfigured before they are operational.** To designate a 6000i as either master or slave, press and hold the **STAR** key for about a minute or so while turning the unit on. A special screen is displayed that allows selection of the proper mode.

The GPS antenna must be connected to the master unit.

It is recommended that the optional radar and/or echo sounder, and other NMEA devices also be connected to the master unit, for two reasons:

- if an NMEA device is connected to a slave unit, that slave must be turned on and operating for that device to be functional across the network
- should there be a failure in the master unit, a slave could be temporarily moved to that location, and this is easier to accomplish if all interfaces connect to that same unit

However, NMEA devices can be connected to any networked unit, if necessary. The optional heading sensor must be connected to the same unit as the radar.

## Restrictions on networking

There are only four restrictions on the use of N2 networking. These restrictions must be observed, or the network will not function.

- one and only one master must be a part of any N2 network
- the master unit must be turned on at all times when the system is in use
- all units on the network must have the same software revision
- a maximum of five units may be connected on any network

If the master unit becomes unavailable for any reason, the user is prompted with instructions to temporarily designate a slave unit as a master.

## Technical details

---

The networking port found on the Northstar *6000i* and other Northstar N2 devices conforms to the electrical specifications set forth by the IEEE 802.3u 100Base-TX standard. This standard is also referred to as "Fast Ethernet." The cabling used is data grade category 5 or 5e Unshielded Twisted Pair (UTP) terminated with RJ-45 connectors on both ends. The standard allows for transmission of raw data at speeds of 10 and 100 Megabits per second depending on the device being communicated with. Although Fast Ethernet is a commonly used standard, particularly in computer Local Area Networks and peripherals, the *6000i* should only be connected to equipment specified by Northstar.

## Installation Planning

---

The two primary considerations in planning an installation are:

- which connections need to be **waterproof**
- **how many** devices will be connected (two, or more than two)

Ethernet cables should be kept several inches away from power cables and other wiring that might generate interference (such as radar and echosounder cables). When necessary, Ethernet cables should cross these other cables at right angles.

## Step 1: Waterproofing

### Dry locations

If all components are located in dry areas and do not require waterproof cables and connectors, standard off-the-shelf Ethernet cables can be used. These cables are available in a variety of lengths and can be obtained from sources that carry computer networking supplies. The installer should ensure that the cable is category 5 or category 5e cable. Other cables, particularly voice grade cables, look very similar but will not work as part of the N2 system.

### Wet locations

Any connectors exposed to the weather or possibility of exposure need to be waterproof. Cables can be ordered from Northstar with waterproof connectors installed on both ends, or (for installations that require passing the cable through a small hole or wiring tube) with a waterproof connector installed on one end and a kit containing all parts needed to field-install a waterproof connector on the other end.

Cables are also available with a waterproof connector on one end and a non-waterproof connector on the other.

Installation type	Networking equipment required
All equipment is located in dry areas	Commercially available standard Ethernet cables and switches can be used
One or more N2 devices are located in exposed areas, and others (including the switch) are located in protected areas.	Use a standard Ethernet switch. Use cables with a waterproof connector on the exposed end and a standard open connector on the other end. Be sure to route the cables so that water does not find its way into the switch.
All N2 devices including the switch are located in exposed areas	Fully waterproof equipment such as that available from Woodhead Connectivity must be used.

## Step 2: Number of devices

The initial survey should also determine whether or not an Ethernet switch will be needed. A switch is only necessary if the installation includes **more** than two N2 devices.

### Connecting a network of two devices

The simplest way to interconnect a network consisting of just two devices is to use an Ethernet “crossover” cable. A crossover cable eliminates the need for an Ethernet switch.

### Connecting a network of more than devices

When more than two devices are being connected, or if you wish to leave room for future expansion, use an Ethernet switch that serves as a common connection point for all devices. Switches are available in both standard and waterproof versions. **Never use crossover cables with a switch.**

## Ethernet cables

After determining the need for waterproofing and the type of cable required as described above, select the specific cables needed:

- waterproof or not (for each end)
- crossover or straight through
- both connectors installed, or one connector not installed for threading through a wiring tube or bulkhead hole

The maximum cable length between any two devices should not exceed 100 meters.

### Using store-bought cables

Non-waterproof cables obtained at a local computer store can be used in the situations shown below. These cables and the units they connect to will be quickly destroyed by exposure to water, so use them only in completely protected locations. Again, be sure to use only category 5 or category 5e cables.

#### Non-waterproof crossover cables (purchased locally)

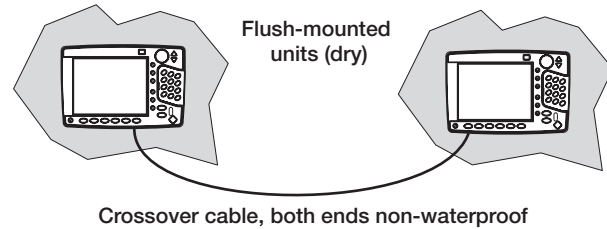

P/N	Length	Type	Cable end 1	Cable end 2
N/A	as needed	Crossover	Non-waterproof	Non-waterproof

#### Non-waterproof straight-through cables (purchased locally)

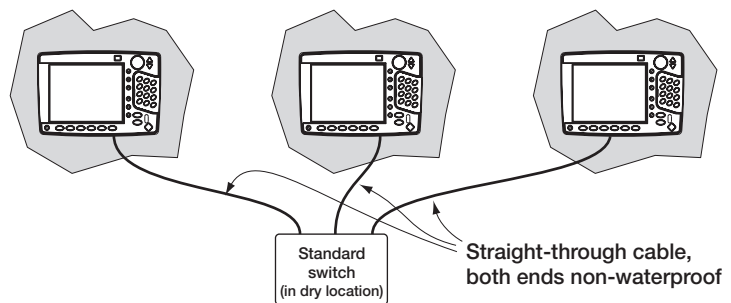

P/N	Length	Type	Cable end 1	Cable end 2
N/A	as needed	Straight-through	Non-waterproof	Non-waterproof



## Cable styles available from Northstar

### Fully waterproof crossover cables

The following waterproof crossover cables are available from Northstar for connecting exactly two N2 devices that are exposed to water.

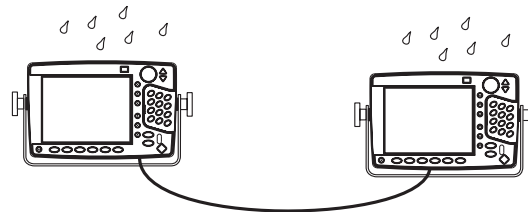

Crossover cable, waterproof both ends

P/N	Length	Type	Cable end 1	Cable end 2
WA575-A	3 feet (1 m)	Crossover	Waterproof	Waterproof
WA562-A	15 feet (5 m)	Crossover	Waterproof	Waterproof
WA563-A	30 feet (10 m)	Crossover	Waterproof	Waterproof
WA576-A	60 feet (20 m)	Crossover	Waterproof	Waterproof

All cables in the table above are normally stocked by the factory.

### Fully waterproof crossover cables with one end unwired

The following cables are identical to those described above, except that one connector is not installed, so the cable can be fished through a hole or tube. A kit containing the second waterproof connector is included for installation by the technician (this requires special tools – see page 25)

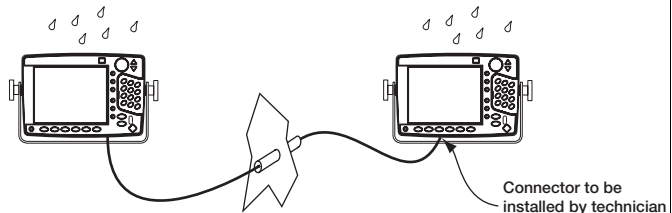

Crossover cable, one end waterproof, other end unwired for fishing through small space

P/N	Length	Type	Cable end 1	Cable end 2
WA575-B	3 feet (1 m)	Crossover	Waterproof	Waterproof – Not installed
WA562-B	15 feet (5 m)	Crossover	Waterproof	Waterproof – Not installed
WA563-B	30 feet (10 m)	Crossover	Waterproof	Waterproof – Not installed
WA576-B	60 feet (20 m)	Crossover	Waterproof	Waterproof – Not installed

All cables in the table above are normally stocked by the factory.

**Semi-waterproof straight-through cables**

For applications where the Ethernet switch is mounted in a dry area, straight-through cables with waterproof connectors on one end and non-waterproof connectors on the other are available from Northstar. They are used to connect N2 devices exposed to water to equipment installed in a protected area. They have a waterproof connector on one end and an “open” (non-waterproof) connector on the other end.

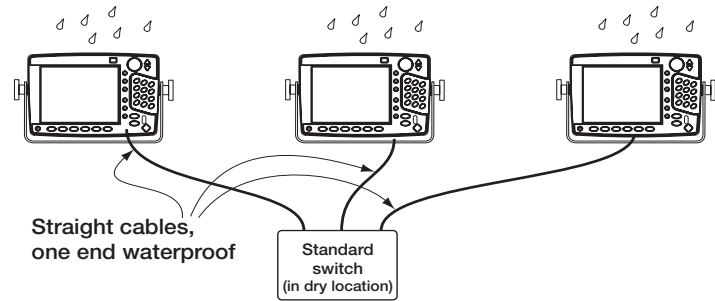

P/N	Length	Type	Cable end 1	Cable end 2
WA578-A	15 feet	Straight-through	Waterproof	Non-waterproof
WA579-A	30 feet	Straight-through	Waterproof	Non-waterproof
WA580-A	60 feet	Straight-through	Waterproof	Non-waterproof

Cables in the table above are not stocked by the factory.

**Semi-waterproof straight-through cables with one end unwired**

The following cables are identical to those described above, except that one connector is not installed, so the cable can be fished through a hole or tube. A kit containing the second non-waterproof connector is included for installation by the technician (this requires special tools – see page 25).

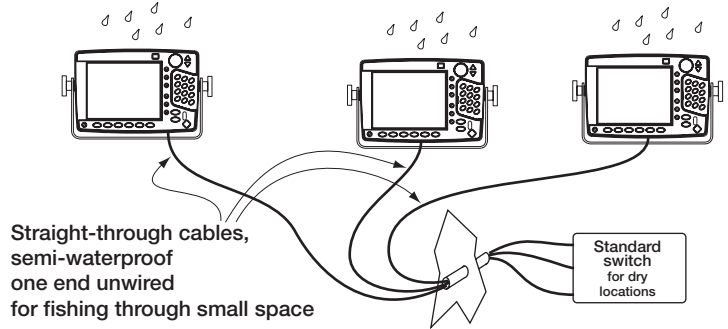

P/N	Length	Type	Cable end 1	Cable end 2
WA578-B	15 feet (5 m)	Straight-through	Waterproof	Non-waterproof – Not installed
WA579-B	30 feet (10 m)	Straight-through	Waterproof	Non-waterproof – Not installed
WA580-B	60 feet (20 m)	Straight-through	Waterproof	Non-waterproof – Not installed

Cables in the table above are not stocked by the factory.

### Fully waterproof straight-through cables

For applications where the Ethernet switch must be mounted in an exposed area, straight-through cables with waterproof connectors on both ends are available from Northstar, or can be purchased directly from Woodhead Connectivity, Ltd. An 8-port waterproof Ethernet switch (DC powered) can be purchased directly from Woodhead Connectivity, Ltd.

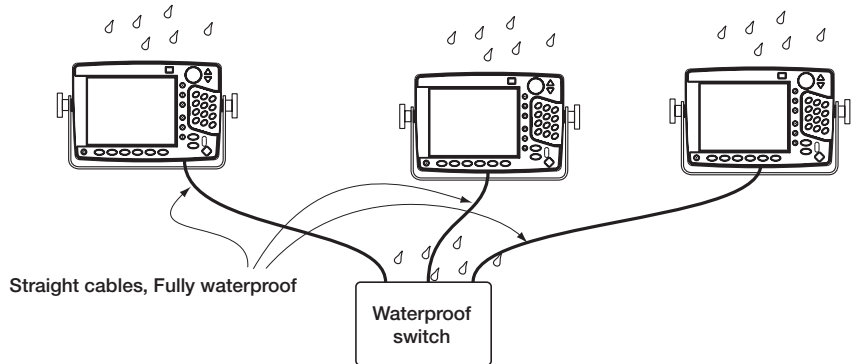

P/N	Length	Type	Cable end 1	Cable end 2
WA560-A	15 feet (5 m)	Straight-through	Waterproof	Waterproof
WA561-A	30 feet (10 m)	Straight-through	Waterproof	Waterproof
WA577-A	60 feet (20 m)	Straight-through	Waterproof	Waterproof

Cable WA 560-A in the table above is normally stocked by the factory.

### Fully waterproof straight-through cables with one end unwired

The following cables are identical to those described above, except that one connector is not installed, so the cable can be fished through a hole or tube. A kit containing the second waterproof connector is included for installation by the technician (this requires special tools – see page 25).

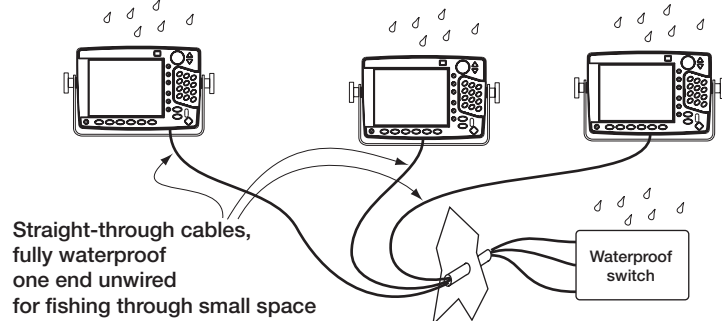

P/N	Length	Type	Cable end 1	Cable end 2
WA560-B	15 feet (5 m)	Straight-through	Waterproof	Waterproof – Not installed
WA561-B	30 feet (10 m)	Straight-through	Waterproof	Waterproof – Not installed
WA577-B	60 feet (20 m)	Straight-through	Waterproof	Waterproof – Not installed

Cables WA561-B and WA577-B in the table above are normally stocked by the factory.

Contact information for Woodhead Connectivity is listed below:

Woodhead Connectivity Ltd.  
 9 Rassau Industrial Estate  
 Ebbw Vale  
 Gwent NP23 5SD  
 United Kingdom.  
 Tel +44 (0)1495-356300  
 Fax +44 (0)1495-356301

The telephone number for US inquiries is 1-800-225-6243. Woodhead Connectivity's web page can be accessed at [www.rjlnxx.com](http://www.rjlnxx.com).

## Fabricating your own cables

With the proper crimping tool, cable and connectors, the installer can also make non-waterproof cables of custom length. You will need the following tools:

- wire stripper (Sargent 8450 or equivalent)
- crimping tool (Sargent 2100 or equivalent)
- crimping tool insert (Sargent 2100-08 or equivalent)

Careful attention should be paid to wiring the connectors using the standard 100Base-TX wiring convention. It should be noted that good cabling is critical to the proper operation of the N2 system and if the installer is inexperienced in building 100Base-TX networking cables, a pre-made cable should be used. Flattening out the wires in the correct order for insertion into the RJ45 jack before crimping can be the most complex part of the job, and it must be done with care.

**Straight-Through Cable Wiring**

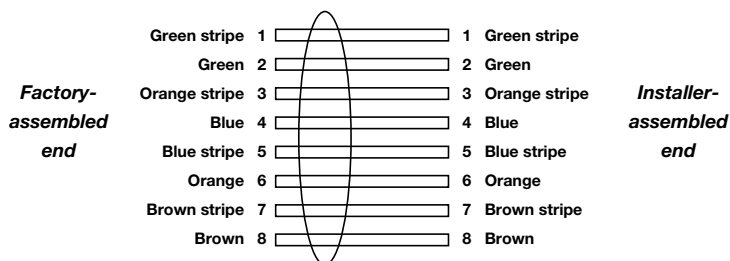

**Crossover Cable Wiring**

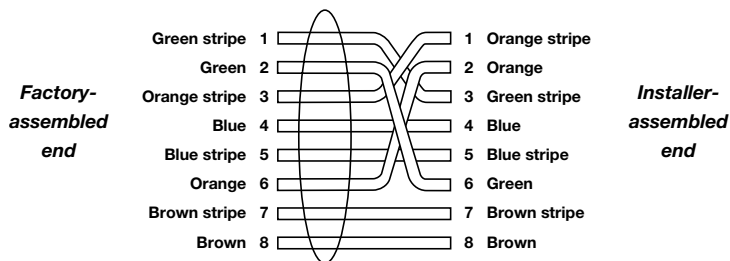

## Installing waterproof connectors

Carefully follow these instructions to install a waterproof connector (P/N KC386) or a non waterproof connector (P/N/ KC390) to an Ethernet cable. Improper installation can affect reliability or allow water leakage. p

1. Route the WW206 cable through the HM1007 heat shrink tubing and the nut, lock, and body of the connector.
2. Use the wire stripper (Sargent 8450) to remove the jacket from the WW206 cable.
3. Install the wire to the RJ45 connector using the crimp tool (Sargent 2100 with insert 2100-08).
4. Insert the RJ45 connector to the connector body and tighten down the nut.
5. Position the heat shrink tubing on the connector body, so that the lock ring can slide back for installation and removal.
6. Apply heat to shrink the tubing.

## Switches

---

### Ethernet switches

Ethernet switches allow for the interconnection of more than N2 devices. Each N2 device can exchange data with any other N2 device connected to the switch.

For non-waterproof switches, any standard 10/100 Mbit Ethernet switch can be used. These devices generally come with a "Wall Wart" type of a power adapter which is plugged into a 110V AC power outlet.

Fully waterproof, DC powered switches are available from Woodhead Connectivity Ltd.

The Northstar *6000i* has been tested with the following Ethernet switches using standard Category 5 cables:

Manufacturer	Model	Northstar P/N	Speed(Mbits)	Ports
Netgear	FS108		10/100 Auto	8
ADAM	6520	SW103		5

Check-out of the N2 networking is described in Section 5.





## SECTION FIVE: Checking out the system

### Turning the 6000i on and off

---

To turn on the 6000i, gently and briefly press the **PWR** key. The unit emits several short beeps as it displays the START-UP screen, then performs a series of self-tests to check its critical components and functions. Next, a message is shown reminding against relying on the 6000i's chart cartography as the only means of safe navigation. To turn the unit off, press and hold the **PWR** key for several seconds, until it turns off.

### Inserting chart cartridges

---

The 6000i uses either Navionics *Classic* cartridges or *XL3* cartridges. Older style Navionics cartridges (used with Northstar 900 series navigators) cannot be used with the 6000i. Cartridges can be inserted or removed at any time, even if the unit is turned on. The cartridge slot is located behind the 6000i's keypad, which opens as shown in Figure 13. The latch is at the left edge of the door. Push it to the right to open the door.

The cartridge only fits one way. If it doesn't slide in smoothly, try the other way. Insert the cartridge gently but firmly with one straight, smooth motion. A cartridge can be safely inserted or removed while the 6000i is turned on.

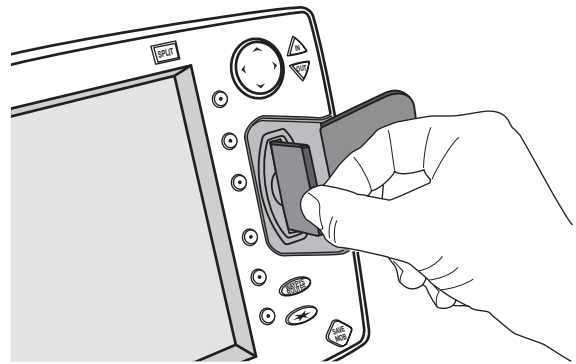

**Figure 13: Inserting a cartridge**

**Be sure to close the door securely to avoid water penetration!**

### Checking satellite status

---

To see information about signals from the satellites, press **POSITION** and then **Sat Info**.

The satellite map on the GPS SATELLITES screen shows the current location of the satellites in the sky. The 6000i displays GPS satellites as circles; WAAS satellites as ovals. You can check the quality

of their signals by looking at each satellite's Signal-to-Noise Ratio (SNR). The higher the ratio, the better the quality.

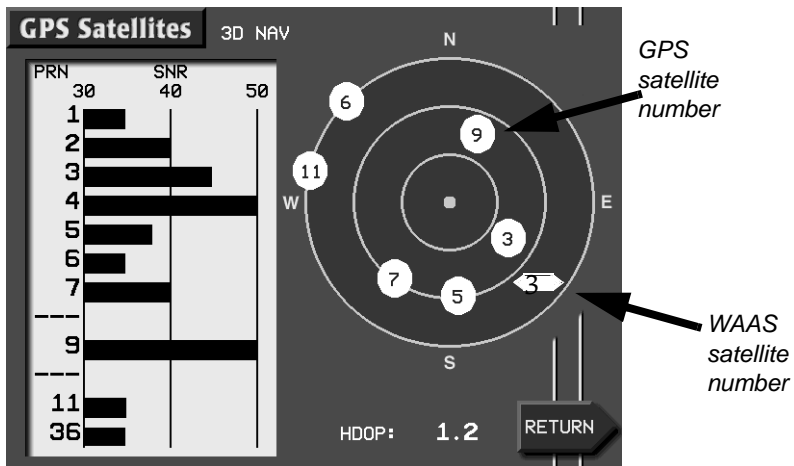

**Figure 14: Satellites on the GPS satellites screen**

Although the U.S. government identifies WAAS satellites by their pseudo random number (PRN)—a three-digit number ranging from 120 to 138—the *6000i* identifies them by two-digit numbers ranging from 33 to 51. For example, the satellite for the Atlantic Operating Region (AOR) is PRN 122, which the *6000i* displays as 35. See Table 8 below for the identification numbers for WAAS satellites that may be displayed on the screen.

**Table 8: WAAS satellite identification numbers**

PRN	120	121	122	123	124	125	126	127	128	129	130	131	132	133	134	135	136	137
ON GPS SATS SCREEN	33	34	35	36	37	38	39	40	41	42	43	44	45	46	47	48	49	50

## Checking DGPS status

If you have connected a SC-104 compatible beacon receiver, press **DGPS INFO** from the GPS POSITION screen to display the DGPS STATUS screen. Check for low noise levels and mid-range SNR readings.

## Installation-test checklist

To check-out the *6000i* system after installation:

1. Turn on the *6000i*, then check for the presence of GPS and WAAS.
2. Review the functions: With a chart cartridge inserted, check that the CHART screen is displayed. (Be sure to close the chart door securely.)
3. Confirm that the GPS RECEIVER options are at the desired setting. Press the **STAR** key to display the OPTIONS/SERVICE INFO screen, then press the **RECEIVER OPTIONS** menu key to display the RECEIVER OPTIONS screen. If necessary, use the cursor pad to move the arrow, press **EDIT**, change to the desired setting, then press **ENTER**.



For more in-depth information about troubleshooting the *6000i* installation, see "SECTION SEVEN: Troubleshooting and servicing the 6000i system" starting on page 45.

## Checking the N2 network

---

If N2 networking connections are used, they can be checked by turning all units on (making sure that one has been designated as the master). Then perform the following test on any unit:

1. Press the **STAR** key several times to display the OPTIONS/SERVICE INFO screen.
2. Press the **MORE** menu key to display the MORE OPTIONS / SERVICE INFO screen.
3. Press the **N2 Status** menu key.
4. All units detected by the networking software are listed, with their model number and serial number.
5. Check that all units are present. If any are missing from the list, check their cabling and master slave designation. Check that the switch (if present) has power and that its status lights are flashing for all connected units.

SECTION FIVE: Checking out the system



## SECTION SIX: Interfacing the 6000i system

This section describes the use of the NMEA, AUX, VGA and VIDEO connections. For N2 Networking using the Ethernet connections, see "SECTION FOUR: Networking the Northstar 6000i" beginning on page 17

A typical fully-loaded system with all options installed might be wired as follows:

Connector	Port	Direction	Device
NMEA	NMEA 1	IN	Heading Sensor
		OUT	Autopilot and other NMEA RS-422 devices
	NMEA 2	IN	Radar data
		OUT	Radar control
	RS-232	IN	Beacon Receiver
		OUT	RS-232 data copied from Port 1
HONK OUT	OUT	Remote honk, 200 pppm or remote power control	
AUX	AUX	IN	Sounder data
		OUT	Sounder control
VGA	VGA	OUT	VGA video out to computer monitor or other 640 X 480 resolution display
VIDEO	VIDEO	IN	Video in from any NTSC video source

## The NMEA connector

The 6000i's NMEA connector contains the following functions: NMEA Port 1, NMEA Port 2, RS-232 Port, and the "Honk," "200 pppm" or "remote power control" signal.

### Wiring the NMEA connector pins

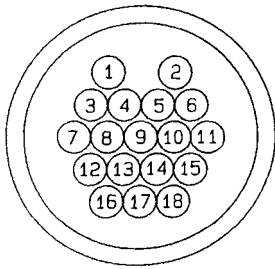

**Figure 15: NMEA connector pin configuration**

**Table 9: NMEA connector pins**

Description	Wire color	Pin
NMEA port 1 input A	brown	3
NMEA port 1 input B	blue	1
NMEA port 1 input ground	white with blue stripe	4
NMEA port 1 output A	violet	12
NMEA port 1 output B	gray	7
NMEA port 1 output ground	blue with white stripe	8
NMEA port 2 input A	white with brown stripe	6
NMEA port 2 input B	brown with white stripe	2
NMEA port 2 input ground	white	5
NMEA port 2 output A	yellow	15
NMEA port 2 output B	orange	11
NMEA port 2 output ground	black	10
RS-232 ground	tan	17
RS-232 RX	green	16
RS-232 TX	red	18
External ground/foil drain	white with orange shield	9
Reserved	orange with white stripe	13
Honk out/200 PPNM (pulses per nautical mile)/remote power	pink	14

### Configuring the NMEA output ports

You can set each output port to meet the requirements of devices that conform to the NMEA 0183 or other data-format specifications: Press **STAR** to display the OPTIONS/SERVICE INFO screen, then press **PORT SETUP OPTIONS** to display the PORT SETUP OPTIONS screen. Press **PORT 1 SETUP** or **PORT 2 SETUP** to display a list of data-format control options, as shown below.

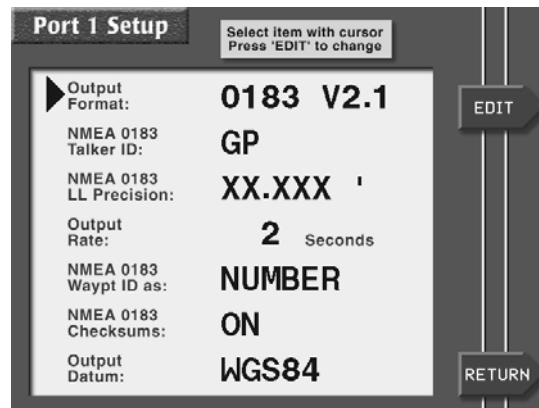

The devices interfacing with the *6000i* may have special requirements; check their installation instructions. The factory settings are appropriate for most devices, but the following are available for special circumstances.

**Table 10: Setup options for the NMEA port**

Setting	Choices
OUTPUT FORMAT (see below)	For port 1, choose NONE, 0183 RAY, or 0183 V2.1. For port 2, choose any of the above plus RADAR
NMEA 0183 TALKER ID (see page 34)	choose GP, LC, or II, to make the <i>6000i</i> look like a GPS receiver, Loran-C receiver, or an “integrated instrument”
NMEA 0183 LL PRECISION (see page 35)	choose hundredths of minutes, thousandths of minutes, or ten-thousandths of minutes
OUTPUT RATE (see page 35)	choose 1 to 999 seconds for the interval at which data is sent to the external device
NMEA 0183 WAYPT ID AS (see page 36)	choose NAME or NUMBER for the identifier of waypoints sent to the external device
NMEA 0183 CHECKSUMS (see page 36)	choose ON or OFF for compatibility with some older devices
OUTPUT DATUM (see page 36)	choose from a list of datums to apply to your lat/lon coordinates, if necessary (The factory default datum is WGS-84)

### Choosing the output format

The *6000i* outputs navigation data in any of several standard formats as required by the receiving, or “listener,” device. The OUTPUT FORMAT option provides the following choices:

- **None** turns the outputs off for when the *6000i* isn’t connected to an external device.
- **0183 Ray** is used when transmitting/receiving position information to or from Raytheon equipment. In Raytheon’s NMEA 0183 format, the checksum isn’t used. (Note: Since the

checksum isn't used, the *6000i* may receive incorrect NMEA data when connected to an external Raytheon Ioran.)

- **NMEA 0183 Version 2.1** is a general-purpose interface output format used by most autopilots, radars, plotters, and other equipment. (NMEA 0183 Version 1.5 sentences—BWC, GLL, and RNN—are included to allow backwards compatibility with marine equipment designed for this earlier version of 0183).
- **Radar** is used when the *6000i* is connected to a Northstar radar. In that case, the remaining options for Port 2 are not used.

### Selecting NMEA output sentences

When you select 0183 or 0183 RAY as the output format (after pressing the **EDIT** menu key) and press **ENTER**, a screen is displayed showing all the NMEA 0183 sentences the *6000i* can output.

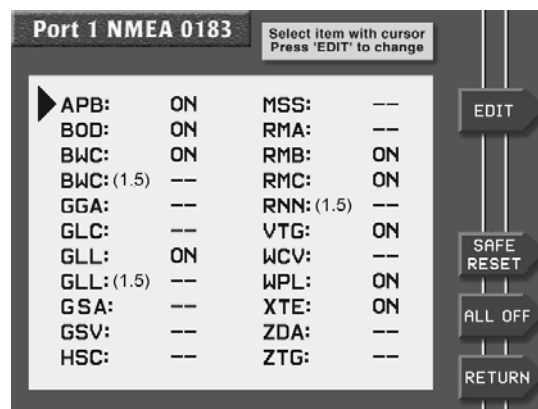

Three-letter abbreviations identify each sentence and are listed alphabetically. (For the meaning of these sentences, see the NMEA interface specifications document published by the NMEA.) The sentences to be output are followed by the word ON; those that won't be output have two dashes indicating that they're off. Some devices can't handle all these sentences correctly, so you can customize the output here by turning individual sentences on or off. In general, you may want to turn on only those sentences used by the particular equipment interfaced to the *6000i*.

### Turning NMEA output sentences on and off

To turn on or off the *6000i*'s NMEA 0183 sentences, first follow the above description to display the 0183 SENTENCE screen, then press the cursor pad to highlight the sentence you want to turn on or off, then press **EDIT**. Press the cursor pad to toggle the sentence on or off, and press **ENTER** to make your selection (or **CLEAR** to leave it unchanged). Repeat for each sentence as desired. When you're done, press **RETURN** to go back to the PORT SETUP screen.

If you want to set all the sentences to the factory settings for recommended output, press the **SAFE RESET** menu key. If you want to turn on only a select few sentences for output, press the **ALL OFF** menu key to turn off all sentences, then turn the desired ones back on.

### Choosing the talker ID

The NMEA 0183 standard requires that the equipment you're interfaced to—the "listener"—knows what type of device is transmitting the data. The *6000i*'s talker ID tells the listener that it is receiving

information from a navigation source, not a communications or sensor device—which transmits completely different forms of data. Certain listening devices will only accept navigation data identified as coming from Loran (LC), GPS (GP), or an integrated instrument (II). The 6000i lets you set its talker ID to LC, GP, or II to match what the listener device is expecting:

1. Check the listener device’s instruction manual to determine which “talker ID” codes it will respond to.
2. At the PORT 1 SETUP or PORT 2 SETUP screen, press the cursor pad to highlight the NMEA 0183 TALKER ID option, then press **EDIT**.
3. Scroll through the three choices using the cursor pad to make your selection, and press **ENTER**. The interfaced equipment will now receive the 0183 data in the correct nav-source format.

### Choosing the lat/lon precision

For more flexibility when communicating with a variety of other devices, you can set the precision level of the 0183 position information output by the 6000i. The choice you make depends on the equipment to which you’re outputting the NMEA data (for the number of digits of precision required for that particular device, see the manufacturer’s instructions). You have three choices:

- XX.XX' (lat/lon precision to two decimal places (hundredths of minutes) or 60 feet)
- XX.XXX ' (lat/lon precision to three decimal places (thousandths of minutes) or 6 feet; this is the factory setting)
- XX.XXXX' (lat/lon precision to four decimal places (ten-thousandths of minutes) or roughly foot)

The 6000i conforms to the NMEA version 2.00 standard, and is also compatible with version 1.50. Electronic and pen plotting devices typically benefit the most from three and four decimal places of precision. However, many older devices (and **some current autopilots**) designed to operate with the original 0183 and other formats **can only function with two-place precision**.

<b>NOTE:</b>	<i>Position information can be output and displayed to four decimal places, but the ability to actually navigate with such accuracy is limited by the accuracy of the Loran and GPS systems. Therefore, choosing more decimal places doesn't necessarily increase navigating accuracy.</i>
--------------	--------------------------------------------------------------------------------------------------------------------------------------------------------------------------------------------------------------------------------------------------------------------------------------------

### Choosing the output rate

The default rate for standard NMEA 0183 output is two seconds. The 6000i lets you use a one-second update interval, a rate of 1 Hz, under limited circumstances, for NMEA and diagnostic data output. Using the 1-Hz output option requires some thought when specifying either NMEA 0183 (NMEA version 2.0) or Raytheon (RAY 0183). Because there isn’t enough time to transmit a large number of sentences within one second, you must select for output only those that are needed. If you select more sentences than can be output in one second, the 6000i displays the following error message: SORRY, CAN'T DO THAT. TOO MANY SENTENCES FOR 1 SEC INTERVAL

In this case, you must select fewer sentences.

If your application requires a longer update period, you can increase the span up to 999 seconds.

### Choosing the waypoint identification (ID)

Many marine devices can display waypoint names if they're output by the 6000i. At the PORT 1 SETUP or PORT 2 SETUP screen, highlight the NMEA 0183 WAYPT ID AS option, then press **EDIT**. Change the option from NUMBER to NAME, and press **ENTER** when done. If capable, the listening device will now display six-character waypoint names.

**NOTE:**

*Be sure to determine whether the listening device can accept waypoint names before you change the NMEA WAYPT ID AS option. Many older devices won't understand this identifier, and using it may cause problems with displaying waypoint information or when following routes.*

*There is no standard for identifying how numbers should be assigned when converting waypoints from names to numbers. When you export waypoint information as numbers to a peripheral device, be aware that numbers aren't sequentially defined and may be re-used on a random basis.*

### Choosing the checksum setting

Some older devices may not accept sentences containing the NMEA 0183 checksum that's output by the 6000i. In such cases, the device may not work properly or at all. If you have problems interfacing to older equipment, you can turn off the NMEA 0183 checksum: At the PORT 1 SETUP or PORT 2 SETUP screen, press the cursor pad to highlight the NMEA 0183 CHECKSUMS option, then press **EDIT**. Press the cursor pad to change the setting from **ON** to **OFF**, then press **ENTER**.

### Selecting an independent NMEA output-port datum

You can adjust the geodetic datum for NMEA 0183 ports 1 and 2, separately from the datum you choose for position display. At the PORT SETUP 1 or PORT SETUP 2 screen, highlight the OUTPUT DATUM option, then press **EDIT**. Scroll through the choices to make your selection. To apply this chosen datum to the lat/lon coordinates in the NMEA 0183 output sentences, press **ENTER**. The standard GPS datum is WGS-84.

### Configuring and using the HONK output

The HONK output can be configured for 200 PPNM, remote power control, all alarms, or anchor alarm. To check or change its function:

1. Press the **STAR** key to display the alarms screen.
2. Press the cursor pad down to select the Honk Output field.
3. Press **Edit**.
4. Press the cursor pad to select the desired output.
5. Press **ENTER**.



## Wiring a high-power output

The 6000i's honk signal is an open-collector output limited to 100mA at 50 volts. If you need a higher current or voltage, connect an external relay as shown in Figure 16.

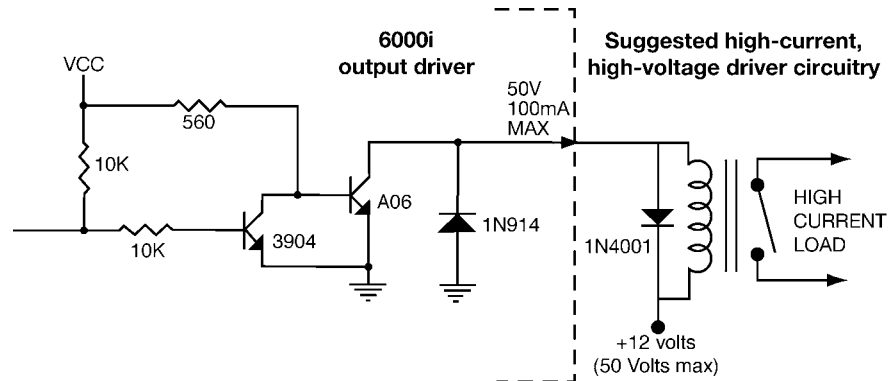

**Figure 16: Wiring for 200 PPNM output**

## Connecting an external alarm

A loud external alarm can be connected to the 6000i. The alarm, called a honker, can be programmed as described above to sound when the anchor watch function detects that the anchor may be dragging, or to sound when any alarm occurs. The alarm is wired to pin #14 on the NMEA connector. See Figure 17 below for wiring. You can use Radio Shack part number 273-060 or an equivalent, or you can connect the alarm output to a relay that sounds the general alarm on the vessel.

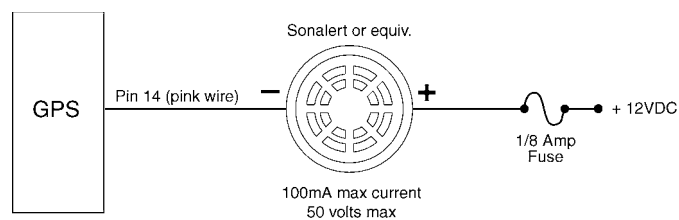

**Figure 17: Pin 14 external alarm connection**

## Using 200 pppm output

The 6000i provides an open-collector transistor output (on pin 14) that's programmed to produce 200 pulses per nautical mile. The emitter of the NPN transistor is connected to ground, and its collector connects to the output pin (see Figure 16: "Wiring for 200 PPNM output," below). The output can sink 100mA, and can withstand a maximum positive voltage of 50 volts. If the output connects to an inductive device such as a relay, a spike suppression diode such as a 1N4001 should be connected across the load. Connect the cathode to the power (+) side of the device and the anode to the 6000i output pin side. The output is normally open, switching to ground for 80ms. It supports speeds from zero to 100 knots (clamps at 100kt).

## Remote power control

The honk output can be used to control the Northstar 491 echo sounder or Northstar radar power by wiring it as shown in the respective installation manuals and configuring the output as described above.

## Configuring the RS-232 port

The RS-232 port on the NMEA connector is used to interface to any compatible SC104 output, or a PC for downloading waypoints or for uploading *6000i* software updates. The following sections describe the RS-232 port's settings for SC-104 in, and "copy port 1" and "copy port 2."

To configure the RS-232 port:

1. Press **STAR** to display the OPTIONS/SERVICE INFO screen, then press **PORT SETUP OPTIONS**.
2. Press the **CURSOR PAD** to select the RS-232 Port Setup line.
3. Press the **CURSOR PAD** to choose the desired function, and then press **ENTER**.

### Using "SC-104 IN" for differential corrections

The SC-104 IN setting lets the *6000i* accept optional differential corrections from any source that transmits the standard SC-104 data stream. When using SC-104 IN, be sure that the BAUD RATE setting matches the beacon receiver's baud rate requirements. (This is the only way to obtain differential corrections with the *6000i*.)

### Using "SC-104 OUT"

The SC-104 OUT setting supplies differential corrections to an external device, based on data from the optional beacon receiver.

### Using "COPY PORT 1" and "COPY PORT 2"

The COPY PORT settings let you interface the *6000i* to most PC's without using an RS422-to-RS232 converter. This function copies the 0183 output of port 1 or port 2 to the *6000i*'s RS-232 port for direct connection to the computer. A number of PC application programs can be used for waypoint/route loading, charting programs, data logging, etc.

<b>NOTE:</b>	<i>You can't use Port 2 when the 6000i is interfaced to a radar.</i>
--------------	----------------------------------------------------------------------

After checking that the desired port is outputting the correct data:

1. Press **STAR** to display the OPTIONS/SERVICE INFO screen, then press **PORT SETUP OPTIONS**.
2. Press the **CURSOR PAD** to select the RS-232 Port Setup line.
3. Change the RS-232 SETUP option to display COPY PORT 1 or COPY PORT 2 by pressing **EDIT**, then pressing the **CURSOR PAD** to change the selection, then pressing **ENTER**. The unit will now copy and output the specified port's data format through the RS-232 port to an external device.

4. To set the baud rate for the RS-232 port, press the **CURSOR PAD** down to select the RS-232 Baud rate. Press **EDIT**, use the **CURSOR PAD** to choose the baud rate, and press **ENTER**.

<b>NOTES:</b>	<p><i>The RS-232 port may overflow (causing data loss) unless the port's baud rate is fast enough to handle the specified sentences. The 6000i may display this precautionary message before you actually enter a new baud rate: WARNING: ALL SENTENCES MAY NOT TRANSMIT AT DIAG BAUD RATE. PRESS "ENTER" TO CONTINUE. In this case, select a slower output rate on the port setup screen of the NMEA port being copied, or remove sentences, or increase the baud rate.</i></p> <p><i>You must configure the PC and its software with the appropriate settings.</i></p>
---------------	--------------------------------------------------------------------------------------------------------------------------------------------------------------------------------------------------------------------------------------------------------------------------------------------------------------------------------------------------------------------------------------------------------------------------------------------------------------------------------------------------------------------------------------------------------------------------

### Using the "EXTERN GPS" setting

This setting can be used to interface the 6000i to an external GPS receiver and use its position coordinates.

### Using the "PORT OFF" setting

Use this setting to reduce the loading on 6000i's the processor when you don't need the RS-232 port's input or output functions.

### About the "DIAGNOSTIC" setting

This setting is only used for troubleshooting at the Northstar factory. Do not use this setting.

## Using the Aux Port

---

The 6000i's Aux Port is used to connect with the optional 491 echo sounder, or for transferring the database of routes and waypoints between the 6000i and many older Northstar units.

To wire the Aux Port for transferring waypoints see Figure 18 or Figure 19.

Pin connections are shown in Table 11.

**Table 11: Aux connector pins**

Description	Wire color	Pin
Shield/Gnd	brown	1*
Remote On Gnd	green	1*
Remote On	white	2
NMEA AUX In (B)	black	3
NMEA AUX Out (B)	orange	4
NMEA AUX Out (A)	violet	5
NMEA AUX In (A)	blue	6
For the Aux Port pin configuration, see Figure 18 on page 41.		

To configure the Aux Port:

1. Press **STAR** to display the OPTIONS/SERVICE INFO screen, then press **PORT SETUP OPTIONS**.
2. Press the **CURSOR PAD** to select the Aux Port Setup line.
3. Press the **CURSOR PAD** to choose Sounder, Database Transfer, or Port off, and then press **ENTER**.

## Connecting two Northstar units for database transfer

You can connect a 6000i to most older Northstar navigators and then transfer one of the unit's waypoints and routes into the other. (Northstar 6000i units can share waypoints and routes between each other using the N2 network). To connect the units, you must fabricate an interface cable and terminate both its ends with the supplied 6-pin solder-cup style cable connectors (P/N KS672). This data-transfer cable is not included. You must select a cable; use only shielded, twisted pair.

To connect a 6000i with a Northstar 952, 951, or 941, the older unit must be using software version 3.12 or higher, and a 10-pin connector (KS653) is required.

### Assembling the cable

*To assemble the cable:*

1. Cut the cable to the desired length.
2. Slide the following parts onto each end of the cable, in the following order:
  - connector backshell
  - rubber-strain relief boot that fits inside the backshell
  - twist lock (also known as a quarter turn), ensuring that it's facing in the correct direction.
3. Trim and prepare the wires for soldering to the connector body.

4. Terminate and solder the appropriate wires to the appropriate pins:
  - For wiring a *6000i* to a 958 or 957, see Figure 18 and Table 12 on page 42.
  - For wiring a *6000i* to a 952, 951 or 941, see Figure 19 and Table 13 on page 43.
5. Slide the twist lock onto the connector body.
6. Screw the connector backshell to the connector body, and tighten.
7. Install the strain-relief clamp with two screws.
8. Connect one end of the cable to the Aux Port at the back of the *6000i*, and the other end into the Aux Port at the back of the older unit.
9. Turn both units on, and configure both units' AUX ports to the D/B TRANSFER function as described above. Turn both units off and on again to initialize the ports.
10. Test for the proper cable connection: a) Press **WAYPTS/ROUTES**; b) Press **IMPORT/EXPORT**; c) Press **IMPORT DATA** or **EXPORT DATA**; d) Press **TEST COMM**. The message should read REMOTE LINK OK. If so, the hardware connection is successful and the two units can now transfer all waypoints and routes between them.

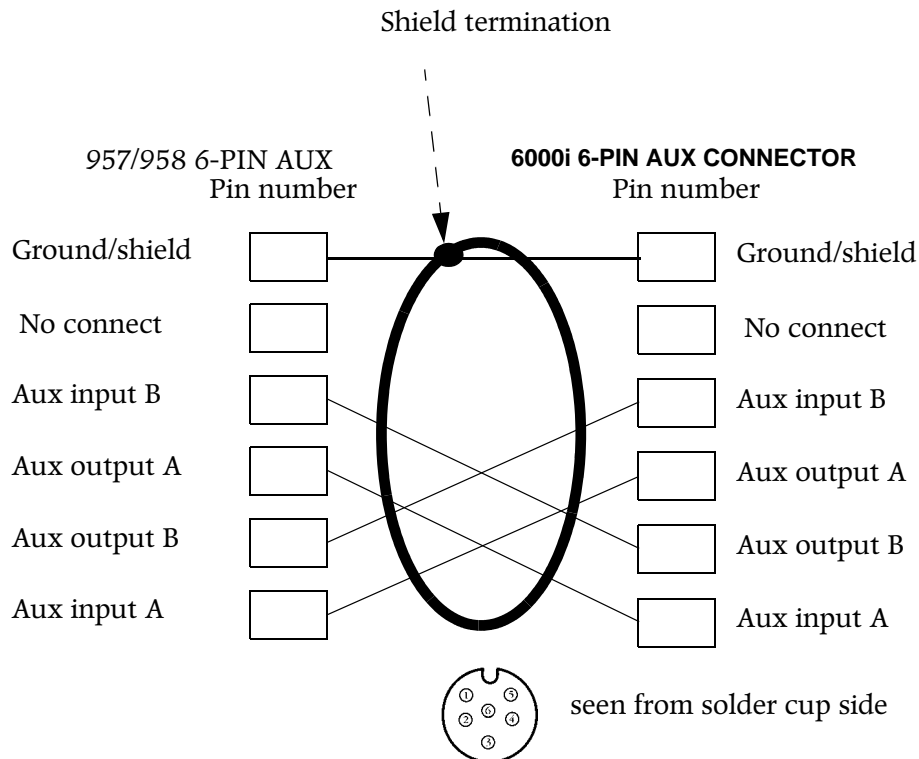

**Figure 18: Connection to a 957 or 958**

**Table 12: 957/958-to-6000i wiring**

957/958 Pin #	Function	6000i Pin #	Function
1	Ground shield	1	Ground shield
2	No connect	2	No connect
3	Aux In B	5	Aux Out B
4	Aux Out A	6	Aux In A
5	Aux Out B	3	Aux In B
6	Aux In A	4	Aux Out A

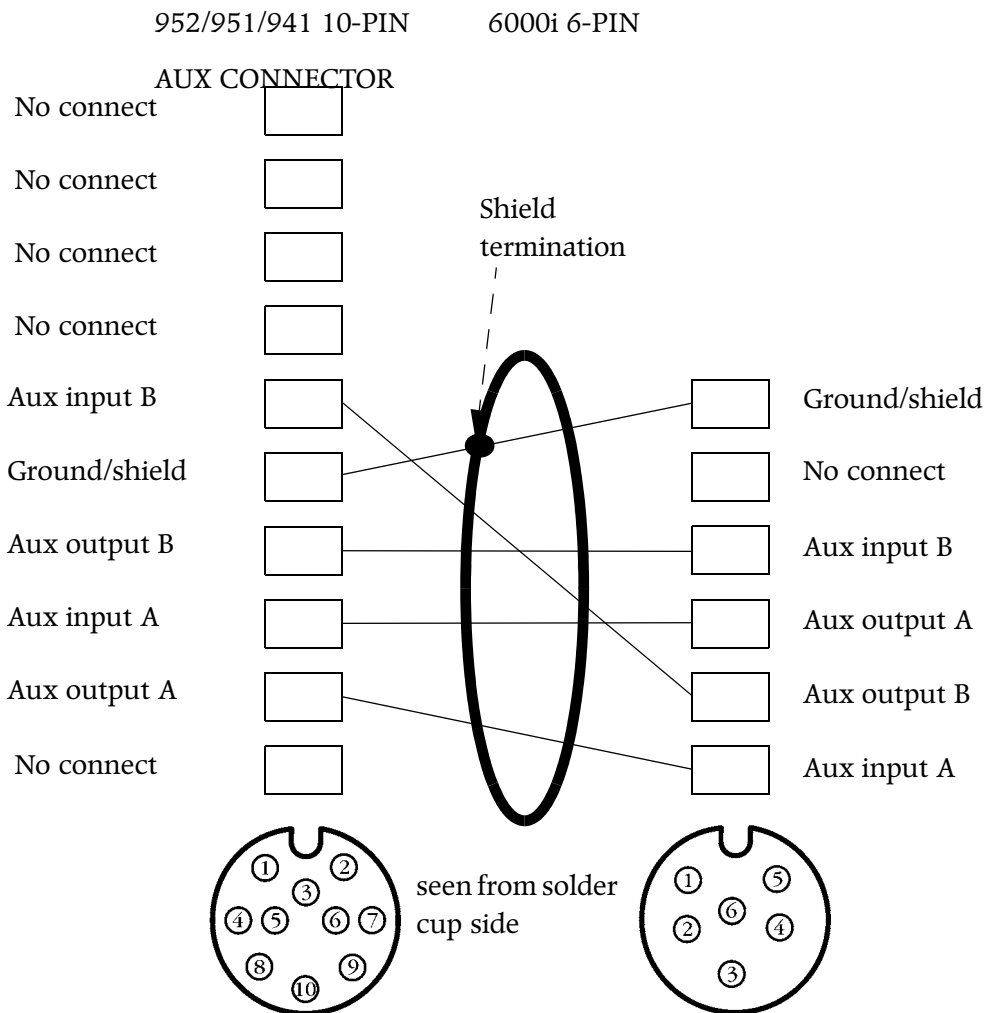

**Figure 19: Connection to a 952, 951 or 941**

**Table 13: 952/951/941 to 6000i wiring**

952, 951, 941 Pin #	Function	6000i Pin #	Function
5	Aux In B	5	Aux Out B
6	Ground shield	1	Ground shield
7	Aux Out B	3	Aux In B
8	Aux In A	4	Aux Out A
9	Aux Out A	6	Aux In A
*Pins 1, 2, 3, 4 and 10 on the 941/951/952 aux connector, and pin 2 on the 6000i aux connector, aren't used.			

## Connecting the 6000i to a remote display

---

The 6000i's VGA connector is used to connect it with a remote display, such as a VGA monitor. A standard VGA cable is used. Northstar doesn't supply the connecting cable since the cable requirements vary with each particular installation. Check the manufacturer's instructions for further cabling and setup details.

## Connecting the 6000i to a video camera

---

The 6000i's BNC VIDEO connector is used to connect to any NTSC- or PAL-compatible device, such as a video camera. Northstar doesn't supply the connecting cable since the cable requirements vary with each particular installation. Check the manufacturer's instructions for further cabling and setup details.

Video signals are not passed over the N2 network. A separate coaxial video cable must be run to any 6000i that will display video.

After you've connected the 6000i to the video device, check the connection by pressing the **VIDEO** key to see the video image. For instructions on moving the image and changing its size, see the *Northstar 6000i Reference Manual (part number GM6KUM)*.







# SECTION SEVEN: Troubleshooting and servicing the 6000i system

## Troubleshooting installation problems

<b>CAUTION!</b> 	<p><i>Make sure that the 6000i doesn't interfere with any other on-board systems. Check all other systems to ensure that their performance doesn't degrade when the 6000i is turned on.</i></p>
------------------------------------------------------------------------------------------------------	-------------------------------------------------------------------------------------------------------------------------------------------------------------------------------------------------

Problem Area	Symptom	Possible Solutions/Reasons
POWER	<ul style="list-style-type: none"> <li>Pressing <b>PWR</b> doesn't start the 6000i</li> </ul>	<ul style="list-style-type: none"> <li>Check the fuse and the power to the 6000i.</li> <li>Press the PWR briefly to turn the system on.</li> </ul>
<b>SYSTEM</b> System lock-ups	<ul style="list-style-type: none"> <li>The system locks up on a random basis with no apparent pattern.</li> <li>The system locks up when using a chart card.</li> <li>System fails any initial self-tests.</li> </ul>	<ul style="list-style-type: none"> <li>Possible internal failure; call your Northstar dealer or the Northstar Service Department for advice.</li> <li>Possible bad chart card. Remove the card, and inspect the pin area of the card and the 6000i for damage. If the pins in the 6000i are bent or damaged, to prevent further damage, don't insert another card. If you're sure the card pins aren't bent, try inserting a new card (turn power off before inserting).</li> <li>Possible internal failure; call your Northstar dealer or the Northstar Service Department for advice.</li> </ul>

Problem Area	Symptom	Possible Solutions/Reasons
DISPLAY	<ul style="list-style-type: none"> <li>The 6000i powers up, beeps, but there isn't any video.</li> </ul>	<ul style="list-style-type: none"> <li>Input voltage may be too low.</li> <li>The display may have failed. Call your Northstar dealer or the Northstar Service Department.</li> </ul>
	<ul style="list-style-type: none"> <li>The display screen dims after the 6000i has been on for a certain time.</li> </ul>	<ul style="list-style-type: none"> <li>The 6000i may be going into auto-dimming mode. Auto-dimming helps maintain the integrity of the display and reduces power consumption when the 6000i is on and running too hot for its current environment.</li> </ul>
	<ul style="list-style-type: none"> <li>Color bars appear where the video overlay image should be.</li> </ul>	<ul style="list-style-type: none"> <li>Check the video cables and the connectors.</li> <li>Check that the video equipment is working properly.</li> </ul>

If ...	Then ...
Satellite signals are often lost, or the unit works while you're travelling in one direction, but not the opposite one.	<p>The antenna may be partially shaded by metallic objects around it. Re-position or raise the antenna away from the object for a better satellite view.</p> <p>Signals may be lost when the antenna is under a bridge or when shielded by buildings.</p>
Poor SNR readings are obtained even after running the 6000i for several minutes	<p>Check the quality of the antenna location—the antenna should have a clear view of the sky. For the correct antenna placement, see Figure 8 on page 14.</p> <p>Make sure the antenna is clean, and not covered with ice, snow, or exhaust soot.</p>
You're having difficulty obtaining WAAS satellites	<p>Check that WAAS is available in your operating area.</p> <p>Reset the 6000i's satellite elevation setting to its default (5 degrees).</p> <p>Check that the 6000i's DIFFERENTIAL OPTIONS option is set to WAAS.</p>

## Getting technical support

---

### Contacting Northstar

After you've followed the instructions in this manual, if you need technical assistance or have any other service-related questions, you can contact the Northstar Service Department. Please be as complete and accurate as possible when describing the problem so that a service technician can research the problem and provide the quickest response. You can reach Northstar's Service Department by e-mail, fax, U.S. mail, or phone as described in Table 14 below. Northstar's Service Department is available between 9:00 AM and 5:00 PM Eastern Time, Monday through Friday, excluding major holidays. To buy spare, replacement, or missing parts, and to get brochures and product information, contact the Northstar Sales Department.

<b>NOTE:</b>	<i>Please have the 6000i's serial number — available on the back of the unit or on the OPTIONS/SERVICE INFO screen — ready before contacting Northstar's Service Department. For help with software questions, please have your software version number available (press the STAR key several times to display the Options/Service Info screen).</i>
--------------	------------------------------------------------------------------------------------------------------------------------------------------------------------------------------------------------------------------------------------------------------------------------------------------------------------------------------------------------------

**Table 14: Contacting Northstar**

<b>Email:</b> Service: <a href="mailto:service@NorthstarNav.com">service@NorthstarNav.com</a> Sales: <a href="mailto:sales@NorthstarNav.com">sales@NorthstarNav.com</a>
<b>Fax:</b> Service: 978/897-1595 Sales: 978/897-7241
<b>Telephone:</b> Main number: 978/897-6600 or 800/628-4487
<b>U.S. mail:</b> Northstar 30 Sudbury Road Acton, MA 01720 USA
<b>Website:</b> <a href="http://www.northstarnav.com">www.northstarnav.com</a> (you can send e-mail to Northstar directly from this site, and access additional technical information and download manuals in PDF form under either the <b><i>Product Manuals</i></b> or <b><i>Support</i></b> links).

## Hearing from you

Your feedback is important and helps Northstar ensure that this manual is a valuable resource for all marine technicians. E-mail your comments or suggestions about this manual to the following address: [manuals@northstarnav.com](mailto:manuals@northstarnav.com).

## Using the Dealer Express web pages

Northstar dealers can get service information online by going to the Dealer Express area on Northstar's website. Contact Northstar for your dealer password before clicking on the [Dealer Express](#) link. This area includes the following topics:

- service bulletins (for known issues and solutions)
- software update information (for new software features)
- service request form (for sending systems back)
- service status request form (for systems currently under repair)
- owner registration form (for registering new products)

## Obtaining software updates

Periodically, Northstar posts software-update manual addenda on its website ([www.northstarnav.com](http://www.northstarnav.com)) under the [Product Manuals](#) link.

### For dealers

Dealers can call the Northstar Sales Department to order current software updates.

### For users

*6000i* users should contact their respective dealer for software updates. Northstar does not recommend that operators install software updates. If an update is installed incorrectly by mistake, you may lose data and the *6000i* may not work properly. Software updates aren't covered by the Northstar warranty.

## Returning a *6000i* for service

*6000i* repairs are performed only by authorized Northstar dealers or at the Northstar factory. Service includes a complete hardware and software check-out. For a system under warranty, shipping charges to the factory are the only cost for factory repair. The repaired unit will be returned via prepaid economy ground freight (units returned overseas are chargeable). The *6000i* and any accessories returned for warranty repair that are determined to be without fault are subject to labor and handling charges.

<b>NOTE:</b>	<i>For unit still under warranty, field repairs aren't authorized and will void the warranty! Please contact the Northstar Customer Service Department if you need clarification, or need assistance with having repairs done.</i>
--------------	------------------------------------------------------------------------------------------------------------------------------------------------------------------------------------------------------------------------------------

<b>NOTE:</b>	<i>Before returning the 6000i to the Northstar factory, to prevent delays, it is critical that you first obtain a Return Materials Authorization (RMA) number from the Northstar Service Department. If the unit was purchased through a dealer, call the dealer with the unit's serial number so they can help you get an RMA number. Shipments without a proper RMA number will not be accepted.</i>
--------------	--------------------------------------------------------------------------------------------------------------------------------------------------------------------------------------------------------------------------------------------------------------------------------------------------------------------------------------------------------------------------------------------------------

<b>CAUTION!</b> 	<i>Always back-up any important user-defined waypoints and routes before returning the unit for repair. See the Northstar 6000i Operator's Manual for details.</i>
------------------------------------------------------------------------------------------------------	--------------------------------------------------------------------------------------------------------------------------------------------------------------------

If you have overnight or second-day shipping requirements, before shipping the unit, please call the factory for turnaround time, freight charges, and payment arrangements.

The 6000i should be shipped only in a properly designed carton with packing material, and to the Northstar factory at the following address: Northstar Service Department, 30 Sudbury Road, Acton, MA 01720 USA.





# APPENDIX A: 6000i system technical specifications

**Table 15: 6000i technical specifications**

<b>GPS specifications</b>	
Accuracy	3 meters (Selective Availability off) 2 meters with WAAS
<b>Physical features/environmental</b>	<b>Interfacing</b>
Waterproof control head; waterproof chart cartridge door	Two bi-directional NMEA I/O ports, 1 AUX port
6.4", 8.4" or 10.4" diagonal color LCD	One bi-directional RS-232 port
Unsurpassed sunlight viewability	Interfaces to optional Northstar 491 for fishfinding or to an optional Northstar radar
640x480 pixel, hi-temp, backlit, transmissive color LCD	Waypoint upload/download capability to a PC (with appropriate software) or to older Northstar units on non-networked 6000i units
High-contrast anti-reflective screen	One VGA out port
Large, easy-to-use backlit controls	One NTSC/PAL VIDEO in port
Easy interfacing I/O connector	NMEA input sentences: WPL and others
0 degrees Celsius - 55 degrees Celsius max 95% relative humidity, noncondensing	200 PPNM speed output Honk output NMEA output sentences: APB, BOD, BWC, GGA, GLC, GLL, GSA, GSV, LCD, HSC, MSS, RNN, RMC, RMA, RMB, VTG, WCV, XTE, ZDA, ZTG. (Conforms to NMEA v 2.0 and later. Supports 1.5 GLL and BWC.)
Flush mount standard	Accepts most external loran receivers
10 - 36 volts DC power, 30 watts max	Networking between two to five 6000i units, including seamless sharing of navigation, waypoints and routes, radar, and sounder data.

