

SV-640EXWH Exterior Wedge Camera

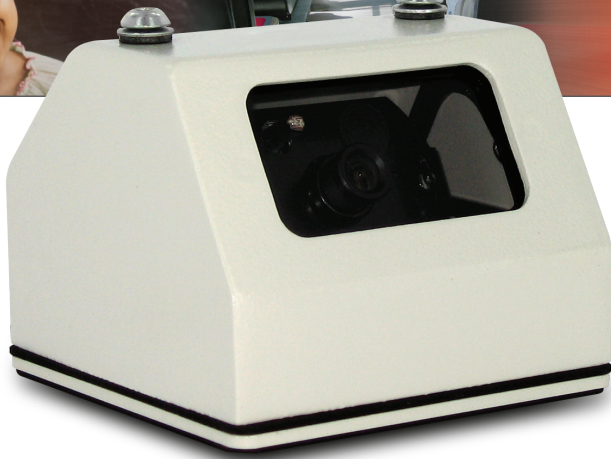

The exterior wedge camera is a compact mobile-rated camera that mounts easily in a variety of orientations. It can withstand typical road vibrations and harsh environments for long lasting performance. As a day/night camera, you can rely on getting the clearest image possible even in dim conditions.

High Performance

The 12mm lens size provides clear details of the surrounding area and the built-in microphone enables audio recording so you can hear as well as see what is happening. Even in dimly lit areas, the camera captures pictures giving you the clearest images possible.

Reliable

The mobile rated camera has a built-in heater so it can withstand road vibrations and harsh environments for long lasting performance. It is tamper proof and designed to ensure maximum protection from moisture condensation so you can rely on getting quality video footage.

Convenient

A variety of lens sizes and camera housings are available. The camera is compatible with other Safety Vision products so you can minimize vendors making future maintenance and purchases more convenient.

Features

- Mobile rated camera with built-in heater for long lasting performance.
- The 12mm lens size provides clear details and the built-in microphone enables audio recording.
- The day/night camera captures images even in dim light giving you the clearest possible pictures.
- Vandal and tamper proof with a IP67 rating for waterproof and dustproof intrusion.
- The camera is compatible with other Safety Vision products so you can minimize vendors.



SPECIFICATIONS

SV-640EXWH Exterior Wedge Day/Night Camera

Image Sensor	1/3 inch High Resolution Interline CCD
Signal Format	NTSC Standard
Lens Focal Length	12 mm (3.6 mm, 4 mm, 6 mm also available)
Synchronization	Internal
Resolution	560 TV Lines
Picture Elements	768 (H) x 494 (V)
Minimum Illumination	0.1 lux at F1.2 (color) 0.05; lux at F1.2 (black & white)
Signal-to-Noise Ratio	> 50 dB (AGC off)
Electronic Shutter	1/60 - 1/100,000 second, auto shutter
Output Signal	1.0 Vp-p, 75 ohms
Gamma	0.45
Auto Gain Control	Yes
Power Supply	12V DC
Power Consumption	170 mA
Construction	Aluminum Sheet Metal with polycarbonate window
Operating Temperature	-58°F ~ 140°F (-50°C ~ 60°C)
Dimensions (w x h x d)	4.0 in. x 4.0 in. x 3.34 in.
Weight	.08 lb. (29 g)

SV-LCD70 Monitor

Screen Size	7-inch Diagonal
Resolution	1440 x 234
Video System	NTSC Standard
View Angle (T/B/L/R)	50/70/70/70
Dimmer	Auto/Manual Selectable
OSD Controls	Bright, contrast, color, tint, image selectable CA 1 (mirror view or true view), auto scan time, scale (on/off)
Impact Rating	6 G
Synchronization	Internal
Power Supply	12V DC
Power Consumption	10W
Operating Temperature	-4°F ~ 140°F (-20°C ~ 60°C)
Dimensions	7.8 in. x 5.4 in. x 1.3 in.
(w x h x d)	(197 mm x 136 mm x 32.2 mm)
Weight	.2.2 lbs. (1 kg)

SV-640EXWH Exterior Wedge Camera



SV-640EXWH

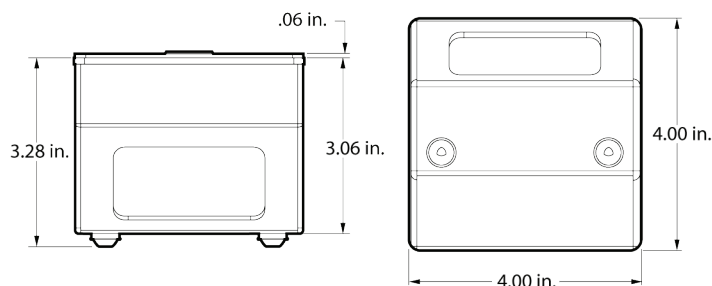

Camera Dimensions

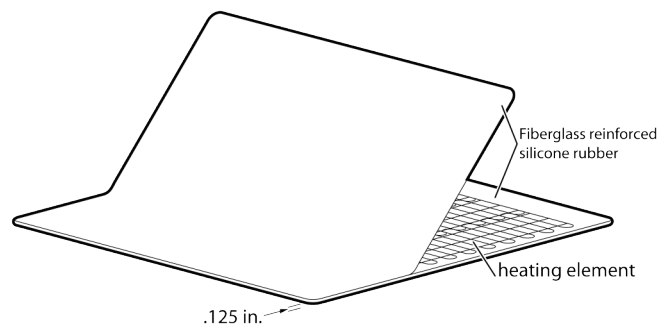

Heating Element Diagram

Optional Accessories



7-inch LCD Monitor (SV-LCD70)



Control Box
(SV-LCD70-CBQ-KIT)

CORPORATE HEADQUARTERS

6100 W. Sam Houston Pkwy. N.
Houston, TX 77041-5113
Main: 713.896.6600
Toll Free: 800.880.8855
Fax: 713.896.6640

www.safetyvision.com

SAFETY VISION®

Mobile video solutions for enhanced safety