

Vertex Standard

VX-2200(LTR) SERIES

OPERATING MANUAL

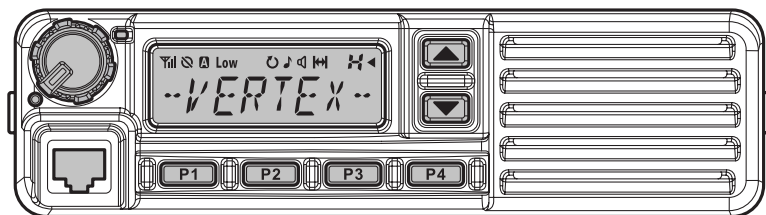

Vertex Standard LMR, Inc.

4-6-8 Shibaura, Minato-ku, Tokyo 108-0023, Japan

————— **Congratulations!** —————

You now have at your fingertips a valuable communications tool: a Vertex Standard two-way radio! Rugged, reliable and easy to use, your Vertex Standard radio will keep you in constant touch with your colleagues for years to come, with negligible maintenance downtime.

Please take a few minutes to read this manual carefully. The information presented here will allow you to derive maximum performance from your radio, in case questions arise later on.

We're glad you joined the Vertex Standard team. Call on us anytime, because communications is our business. Let us help you get your message across.

Notice !

There are no owner-serviceable parts inside the transceiver. All service jobs must be referred to an authorized Vertex Standard Service Representative. Consult your Authorized Vertex Standard Dealer for installation of optional accessories.

INTRODUCTION

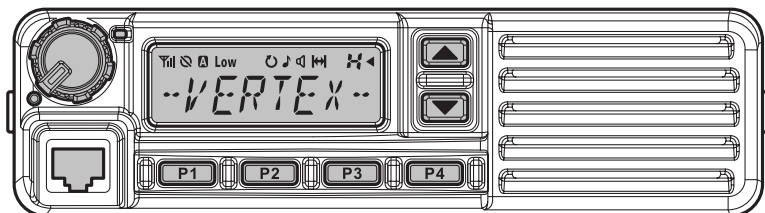

The **VX-2200(LTR)** Series are full-featured FM transceivers designed for flexible mobile and base station business communications in the VHF or UHF Land Mobile bands. These transceiver are designed for reliable business communications in a wide variety of applications with a wide range of operating capability provided by their leading-edge design.

The 250-group memories can each be programmed with a 8-character group name. Important channel frequency data is stored in EEPROM and flash memory on the CPU, and is easily programmable by dealers using a personal computer and the Vertex Standard Programming Cable and **CE94** Software.

The pages which follow will detail the many advanced features provided on the **VX-2200(LTR)** Series transceiver. After reading this manual, you may wish to consult with your Network Administrator regarding precise details of the configuration of this equipment for use in your application.

For North American Users Regarding 406 MHz Guard Band

The U.S. Coast Guard and National Oceanographic and Atmospheric Administration have requested the cooperation of the U.S. Federal Communications Commission in preserving the integrity of the protected frequency range 406.0 to 406.1 MHz, which is reserved for use by distress beacons. Do not attempt to program this apparatus, under any circumstances, for operation in the frequency range 406.0 - 406.1 MHz if the apparatus is to be used in or near North America.

WARNING! FCC RF EXPOSURE REQUIREMENTS

ATTENTION!

BEFORE USING THE RADIO, READ THE “PRODUCT SAFETY GUIDE” CHAPTER ON STARTING FROM PAGE 4 FOR MOBILE TWO-WAY RADIOS WHICH CONTAINS IMPORTANT OPERATING INSTRUCTIONS FOR SAFE USAGE AND RF ENERGY AWARENESS AND CONTROL FOR COMPLIANCE WITH APPLICABLE STANDARDS AND REGULATIONS.

THIS DEVICE COMPLIES WITH PART 15 OF THE FCC RULES. OPERATION IS SUBJECT TO THE FOLLOWING TWO CONDITIONS: (1) THIS DEVICE MAY NOT CAUSE HARMFUL INTERFERENCE, AND (2) THIS DEVICE MUST ACCEPT ANY INTERFERENCE RECEIVED, INCLUDING INTERFERENCE THAT MAY CAUSE UNDESIRE OPERATION.

THE GRANTEE IS NOT RESPONSIBLE FOR ANY CHANGES OR MODIFICATIONS NOT EXPRESSLY APPROVED BY THE PARTY RESPONSIBLE FOR COMPLIANCE. SUCH MODIFICATIONS COULD VOID THE USER’S AUTHORITY TO OPERATE THE EQUIPMENT.

This equipment has been tested and found to comply with the limits for a Class B digital device, pursuant to part 15 of the FCC Rules. These limits are designed to provide reasonable protection against harmful interference in a residential installation. This equipment generates, uses and can radiate radio frequency energy and, if not installed and used in accordance with the instructions, may cause harmful interference to radio communications. However, there is no guarantee that interference will not occur in a particular installation. If this equipment does cause harmful interference to radio or television reception, which can be determined by turning the equipment off and on, the user is encouraged to try to correct the interference by one or more of the following measures:

- Reorient or relocate the receiving antenna.
- Increase the separation between the equipment and receiver.
- Connect the equipment into an outlet on a circuit different from that to which the receiver is connected.
- Consult the dealer or an experienced radio/TV technician for help.

WARNING! IC RSS GENERAL REQUIREMENTS

English

- ❑ This device complies with Industry Canada license-exempt RSS standard(s). Operation is subject to the following two conditions: (1) this device may not cause interference, and (2) this device must accept any interference, including interference that may cause undesired operation of the device.
- ❑ Under Industry Canada regulations, this radio transmitter may only operate using an antenna of a type and maximum (or lesser) gain approved for the transmitter by Industry Canada. To reduce potential radio interference to other users, the antenna type and its gain should be so chosen that the equivalent isotropically radiated power (e.i.r.p.) is not more than that necessary for successful communication.
- ❑ Antennas used for this transmitter (identify the device by certification number, or model number if Category II) must not exceed an antenna gain of 0 dBd. The radio must be used in vehicle-mount configurations with a maximum operating duty cycle not exceeding 50 %, in typical Push-to-Talk configurations. Antenna types having a gain greater than 0 dBd are strictly prohibited for use with this device.

French

- ❑ Le présent appareil est conforme aux CNR d'Industrie Canada applicables aux appareils radio exempts de licence. L'exploitation est autorisée aux deux conditions suivantes: (1) l'appareil ne doit pas produire de brouillage, et (2) l'utilisateur de l'appareil doit accepter tout brouillage radioélectrique subi, même si le brouillage est susceptible d'en compromettre le fonctionnement.
- ❑ Conformément à la réglementation d'Industrie Canada, le présent émetteur radio peut fonctionner avec une antenne d'un type et d'un gain maximal (ou inférieur) approuvé pour l'émetteur par Industrie Canada. Dans le but de réduire les risques de brouillage radioélectrique à l'intention des autres utilisateurs, il faut choisir le type d'antenne et son gain de sorte que la puissance isotrope rayonnée équivalente (p.i.r.e.) ne dépasse pas l'intensité nécessaire à l'établissement d'une communication satisfaisante.
- ❑ Antennes utilisées pour cet émetteur (identifier le dispositif par son numéro de certification ou son numéro de modèle s'il fait partie du matériel de catégorie II) ne doit pas dépasser un gain de l'antenne de 0 dBd. **La radio doit être utilisée** dans des configurations de montage en véhicule avec un maximum d'utilisation en fonctionnement n'excédant pas 50 %, dans des configurations typiques de Push-to-Talk. Types d'antenne ayant un gain supérieur à 0 dBd sont strictement interdits pour une utilisation avec cet appareil.

PRODUCT SAFETY GUIDE

RF Energy Exposure Awareness and Control Information, and Operational Instructions for FCC Occupational Use Requirements.

NOTICE: This radio is intended for use in occupational/controlled conditions, where users have full knowledge of their exposure and can exercise control over their exposure to meet FCC limits. This radio device is NOT authorized for general population, consumer, or any other use.

This two-way radio uses electromagnetic energy in the radio frequency (RF) spectrum to provide communications between two or more users over a distance. It uses radio frequency (RF) energy or radio waves to send and receive calls. RF energy is one form of electromagnetic energy. Other forms include, but are not limited to, sunlight and x-rays. RF energy, however, should not be confused with these other forms of electromagnetic energy, which when used improperly, can cause biological damage. Very high levels of x-rays, for example, can damage tissues and genetic material.

Experts in science, engineering, medicine, health, and industry work with organizations to develop standards for safe exposure to RF energy. These standards provide recommended levels of RF exposure for both workers and the general public. These recommended RF exposure levels include substantial margins of protection.

All Vertex Standard two-way radios are designed, manufactured, and tested to ensure they meet government-established RF exposure levels. In addition, manufacturers also recommend specific operating instructions to users of two-way radios. These instructions are important because they inform users about RF energy exposure and provide simple procedures on how to control it.

Please refer to the following Web sites for more information on what RF energy exposure is and how to control your exposure to assure compliance with established RF exposure limits.

<http://www.fcc.gov/oet/rfsafety/rf-faqs.html>

<https://www.osha.gov/SLTC/radiofrequencyradiation/hazards.html>

PRODUCT SAFETY GUIDE

Federal Communication Commission Regulations

The FCC rules require manufacturers to comply with the FCC RF energy exposure limits for mobile two-way radios before they can be marketed in the U.S. When two-way radios are used as a consequence of employment, the FCC requires users to be fully aware of and able to control their exposure to meet occupational requirements. Exposure awareness can be facilitated by the use of a label directing users to specific user awareness information. Your Vertex Standard two-way radio has a RF exposure product label. Also, this Operating Manual includes information and operating instructions required to control your RF exposure and to satisfy compliance requirements.

Compliance with RF Exposure Standard

Your Vertex Standard two-way radio is designed and tested to comply with a number of national and international standards and guidelines (listed below) regarding human exposure to radio frequency electromagnetic energy. This radio complies with the IEEE and ICNIRP exposure limits for occupational/ controlled RF exposure environment at duty factors of up to 50 % talk - 50 % listen and is authorized by the FCC for occupational use only. In terms of measuring RF energy for compliance with the FCC exposure guidelines, your radio antenna radiates measurable RF energy only while it is transmitting (during talking), not when it is receiving (listening) or in standby mode.

Your Vertex Standard two-way radio complies with the following RF energy exposure standards and guidelines:

- United States Federal Communications Commission (FCC), Code of Federal Regulations; 47 CFR et seq.
- FCC, OET Bulletin 65
- Institute of Electrical and Electronic Engineers (IEEE) C95.1-2005
- International Commission on Non-Ionizing Radiation Protection (ICNIRP)
- Health Canada Safety Code 6
- Industry Canada RSS-102
- Australian Communications Authority Radiocommunications Standard et seq.

PRODUCT SAFETY GUIDE

RF Exposure Compliance and Control Guidelines and Operating Instructions

To control exposure to yourself and others and to ensure compliance with the RF exposure limits, always adhere to the following procedures.

GUIDELINES:

- User awareness instructions should accompany device when transferred to other users.
- DO NOT use this device if the operational requirements described herein are not met.

INSTRUCTIONS:

- **Transmit no more than the rated duty factor of 50 % of the time.** To transmit (talk), push the Push-To-Talk (PTT) button or, for radios equipped with VOX, speak into the microphone. The red LED will illuminate when the radio is transmitting. To receive calls, release the PTT button, or, for radios equipped with VOX, stop talking. The red LED will extinguish when the radio stops transmitting. Transmitting 50 % of the time, or less, is important because this radio generates measurable RF energy exposure (in terms of measuring for standards compliance) only when transmitting.
- **Transmit only when people outside the vehicle are at least the recommended minimum lateral distance away, as shown in Table below, from the body of a vehicle with a properly installed antenna.** This separation distance will ensure that there is sufficient distance from a properly installed (according to installation instructions) externally-mounted antenna to satisfy the RF exposure requirements in the applicable standards listed above.
- **Antennas used for this transmitter must not exceed an antenna gain of 0 dBd.**

NOTE: Table below lists the recommended lateral distance for people in an uncontrolled environment from the body of a vehicle with a properly installed transmitting antenna (i.e., monopoles over a ground plane) with gain equal to or less than the specified maximum gain.

Required Distances

	VHF Model	UHF Model
FCC RF Exposure Requirements	1.64 Feet (0.50 m)	1.35 Feet (0.41 m)
IC RF Exposure Requirements	5.12 Feet (1.56 m)	4.17 Feet (1.27 m)

PRODUCT SAFETY GUIDE

- When a mobile radio is used in conjunction with another co-located transmitter such as a Vehicular Repeater, it is the vehicle operator's responsibility to take appropriate steps to keep bystanders at the required separation distance from the vehicle to ensure compliance with the FCC's RF energy exposure limits for the general population. See the co-located transmitter's user manual for more details.

NOTE: If you are not sure of the rated power of your radio, contact your sales representative or dealer and supply the radio model number found on the radio model label. Users of multi-band radios subject to different separation distances in different operating bands should select the larger applicable distance as the minimum lateral distance for bystanders outside the vehicle. The maximum power on the FCC Grant may be higher than the rated power allowing for production variation.

Mobile Antenna Installation Guidelines

These mobile antenna installation guidelines are limited to metal body motor vehicles or vehicles with appropriate ground planes.

- Antennas should be installed in the center area of the roof or the trunk lid taking into account exposure conditions of backseat passengers and according to the specific instructions and restrictions in the "Installation" Chapter along with the requirements of the antenna supplier.
- Trunk lid installations are limited to vehicles with clearly defined flat trunk lids, and in some cases, to specific radio models and antennas. See the "Installation" Chapter for specific information on how and where to install specific types of antennas to facilitate recommended operating distances to all potentially exposed persons.
- Antennas with gains higher than the authorized maximum gain, unauthorized modifications, or attachments could damage the radio and may result in non-compliance with RF Safety Standards.

PRODUCT SAFETY GUIDE

Compliance and Control Guidelines and Operating Instructions for Mobile Two-Way Radios Installed as Fixed Site Control Stations

If mobile radio equipment is installed at a fixed location and operated as a control station or as a fixed unit, the antenna installation must comply with the following requirements in order to ensure optimal performance and compliance with the RF energy exposure limits in the standards and guidelines listed above:

- The antenna should be mounted outside the building on the roof or a tower if at all possible.
- As with all fixed site antenna installations, it is the responsibility of the licensee to manage the site in accordance with applicable regulatory requirements and may require additional compliance actions such as site survey measurements, signage and site access restrictions in order to ensure that exposure limits are not exceeded.
- For additional installation information, see the guidelines for minimum separation distances provided above in the RF Exposure Compliance and Control Guidelines and Operating Instructions section of this document.

Compliance and Control Guidelines and Operating Instructions for Mobile Two-Way Radios Installed on Maritime Vessels

If mobile radio equipment is installed on a vessel and operated as a fixed unit, the antenna installation must comply with the following requirements in order to ensure optimal performance and compliance with RF energy exposure limits in the standards and guidelines listed above:

- An antenna intended for Maritime operation should be chosen and installed according to the manufacturers recommendations.
- The antennas should be mounted solidly to the vessel structure at the highest location possible.
- As with all radio antenna installations, it is the responsibility of the operator to maintain adequate distances from the antenna and all personnel on board the vessel or adjacent to the vessel.
- For additional installation information, see the guidelines for minimum Separation distances proved above in the RF Exposure Compliance and Control Guidelines and Operating Instructions section of this document.

INSTALLATION

When installing the **VX-2200(LTR)** transceiver, make sure to plan the installation carefully and leave additional room in the rear of the radio for cabling and accessory connections; in the front of the radio for access, controls, and cabling; and to the sides of the radio so that you may access and install the Knob Screws or Hex Head Bolts.

Mounting Bracket Installation

The supplied mounting bracket allows desktop or overhead mounting.

- ❑ Use a 7/32 inch (5.5 mm) bit to drill the holes to a surface which is more 0.4 inch (10 mm) thick and can support more than 3.3 lbs (1.5 kg) and secure the bracket with the supplied screws, spring washers, flat washers, and nuts. You may secure the bracket using the supplied tapping screws, instead of the screws and nuts. In this case, drill the small pilot holes instead of the 7/32 inch (5.5 mm) holes.
- ❑ Install the transceiver to the bracket using the supplied Knob Screws and Washers (or Hex Head Bolts, depending on the situation).



Use only the supplied Knob Screws with Washers, and Hex Head Bolts, or equivalent size screws (HSM5X12).

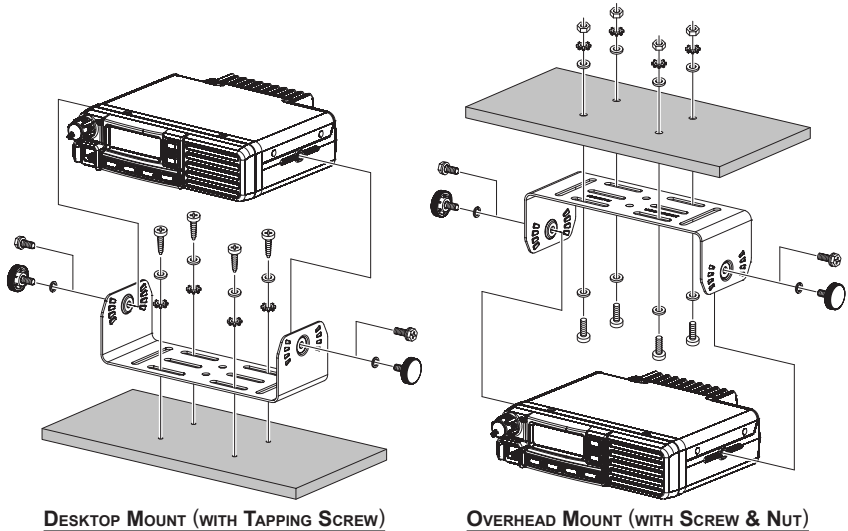

INSTALLATION

Mobile Installation

POWER CONNECTION

VX-2200(LTR) transceiver operates only in negative ground electrical systems. Before starting the installation, make sure that the ground polarity of the vehicle is correct. Accidentally reversing the polarity will not damage the transceiver, but will cause the cable fuses to blow.

To minimize voltage drop and avoid blowing the vehicle's fuses, connect the supplied DC power cable directly to the battery terminals. Do not attempt to defeat or bypass the DC cable's fuse - it is there to protect you, your transceiver, and your vehicle's electrical system.

 **Warning!** Never apply AC power to the power cable of the transceiver, nor DC voltage greater than 15.8 Volts. When replacing the fuse, only use a 15-A fuse. Failure to observe these safety precautions will void the Limited Warranty on this product.

- Before connecting the transceiver, check the voltage at the battery terminals while revving the engine. If the voltage exceeds 15 Volts, adjust the vehicle's voltage regulator before proceeding with installation.

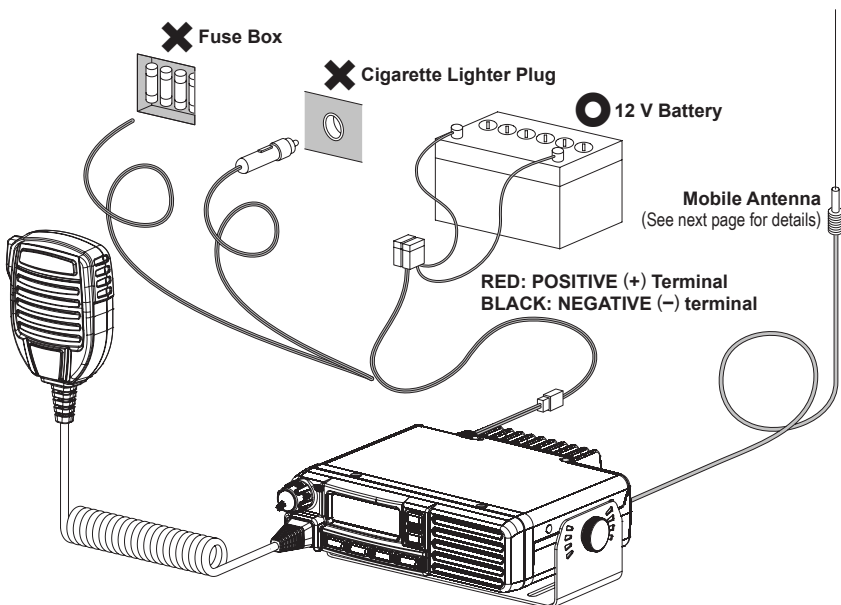

INSTALLATION

- ❑ Connect the **RED** power cable lead to the **POSITIVE (+)** battery terminal, and the **BLACK** power cable lead to the **NEGATIVE (-)** terminal. If you need to extend the power cable, use #12 AWG or larger insulated, stranded copper wire. Solder the splice connections carefully, and wrap the connections thoroughly with insulating electrical tape.
- ❑ Wire the cable so that not to disturb with the driving.
- ❑ Before connecting the cable to the transceiver, verify the voltage and polarity of the voltage at the transceiver end of the DC cable using a DC voltmeter. Now connect the transceiver to the DC cable.

ANTENNA INSTALLATION

The mobile antenna installation is limited to metal body motor vehicles or vehicles with appropriate ground planes.

Antennas mounted on the trunk should be located at least the following distance away from operator and passengers in order to comply with the FCC/IC RF exposure requirements. If can not meet these requirements, the antenna must be placed in the center of the roof.

Required Distances

	VHF Model	UHF Model
FCC RF Exposure Requirements	1.64 Feet (0.50 m)	1.35 Feet (0.41 m)
IC RF Exposure Requirements	5.12 Feet (1.56 m)	4.17 Feet (1.27 m)

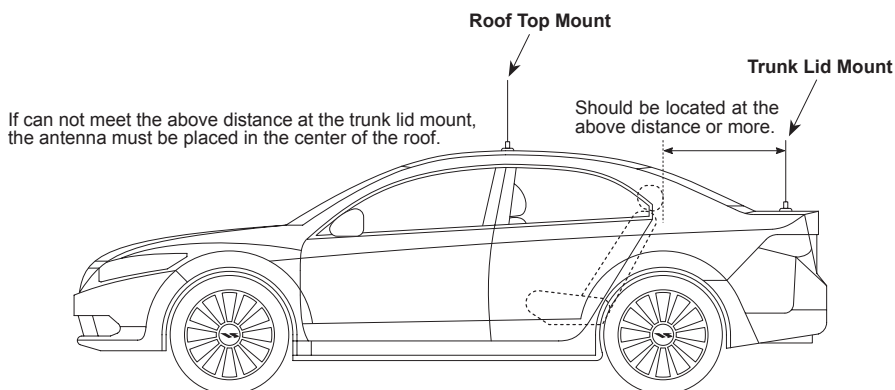

INSTALLATION

Base Station Installation

POWER CONNECTION

Operation of the **VX-2200(LTR)** transceiver from an AC line requires a power supply capable of providing at least 15 Amps continuously at 13.6 Volts DC. Please contact your dealer to select an optimal power supply that satisfy these requirements.

Use the supplied DC power cable for making power connections to the power supply. Connect the **RED** power cable lead to the **POSITIVE (+)** power supply terminal, and connect the **BLACK** power cable lead to the **NEGATIVE (-)** power supply terminal.

ANTENNA INSTALLATION

When used the **VX-2200(LTR)** transceiver as a base station, the antenna installation must comply with the following requirements in order to ensure optimal performance and compliance with the RF energy exposure limits in the standards and guidelines.

- The antenna should be mounted outside the building on the roof or a tower if at all possible.

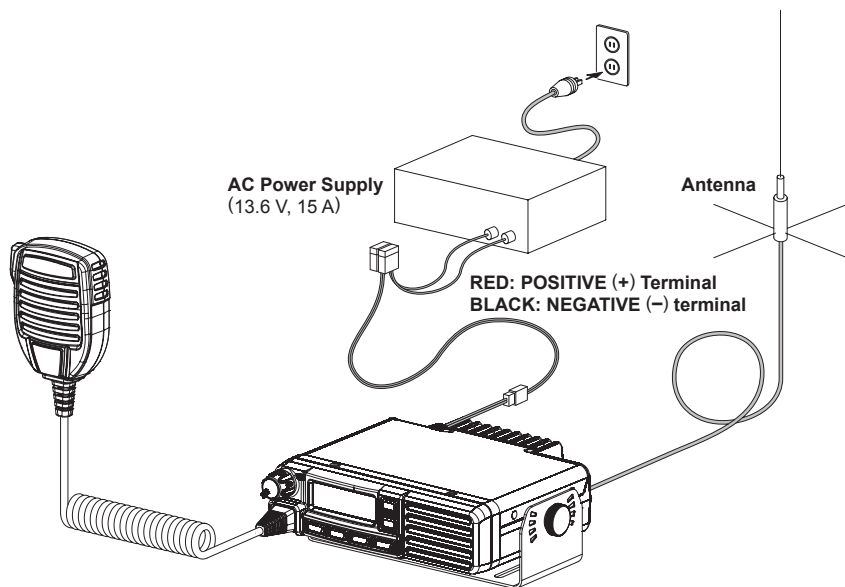

INSTALLATION

- ❑ As with all fixed site antenna installations, it is the responsibility of the licensee to manage the site in accordance with applicable regulatory requirements and may require additional compliance actions such as site survey measurements, signage, and site access restrictions in order to insure that exposure limits are not exceeded.

CONTROLS & CONNECTORS

Front Panel

Important! - All buttons located on the Front Panel are Programmable Function (PF) Buttons, configured according to your network requirements and programmed by your Vertex Standard dealer. The instructions below describe a typically-configured radio.

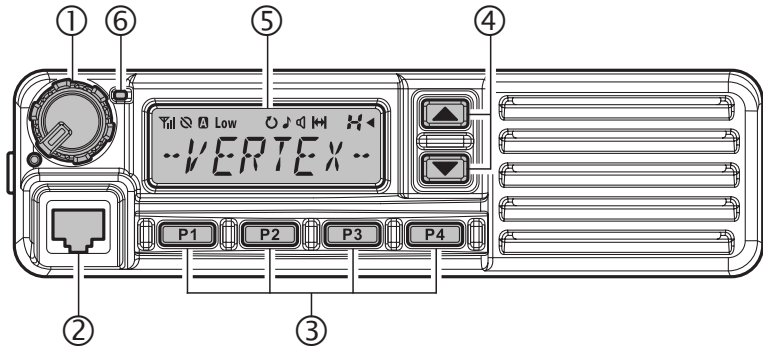

① VOL/PWR Knob

Turn this control clockwise to turn the radio on and to increase the volume. Turn it counterclockwise into the click-stop to turn the radio off.

② Microphone Jack

Connect the microphone plug to this jack.

③ [P1] - [P4] Buttons (Programmable Function Buttons)

These buttons can be set up for special applications, such as High/Low power selection, Monitor, Talk-Around, etc., as determined by your network requirements and programmed by your Vertex Standard dealer.

④ [▼]/[▲] Buttons (Programmable Function Buttons)

In the factory default, pressing either button changes the current group (and displayed group number or name). Holding in either button for more than 1.5 second causes the radio to begin stepping (repeatedly) upward or downward through the groups.

CONTROLS & CONNECTORS

⑤ LCD (Liquid Crystal Display)

The display includes a 8-character alpha-numeric section showing group name tags/identity information and error messages, and an upper icon row displaying feature status (see below).

⑥ TX/BUSY Indicator

Indicates Transceiver's Transmit/Receive Status

CONVENTIONAL ZONE

- Steady Red: Transmitting in progress
- Steady Green: Signaling Off
- Blinking Green: Busy Channel/Squelch Off

LTR TRANKING ZONE

- Steady Red: Transmission in progress
- Steady Green: Zone Busy

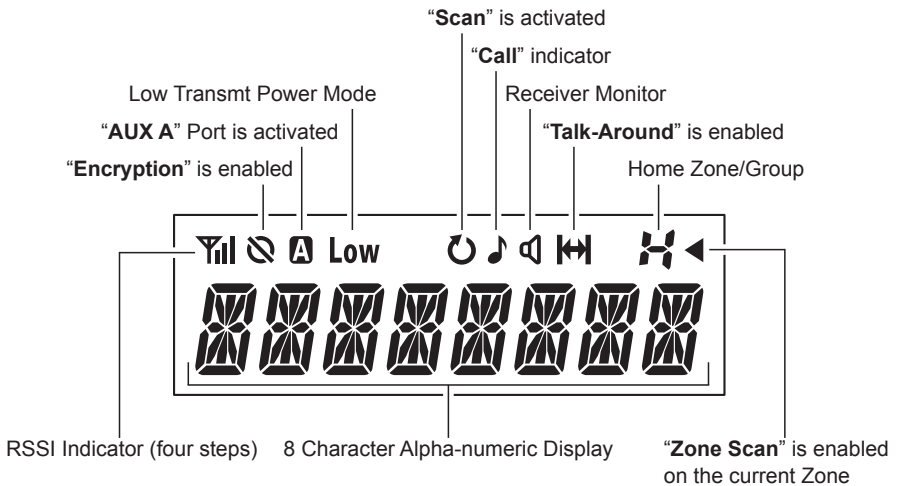

CONTROLS & CONNECTORS

Rear Panel

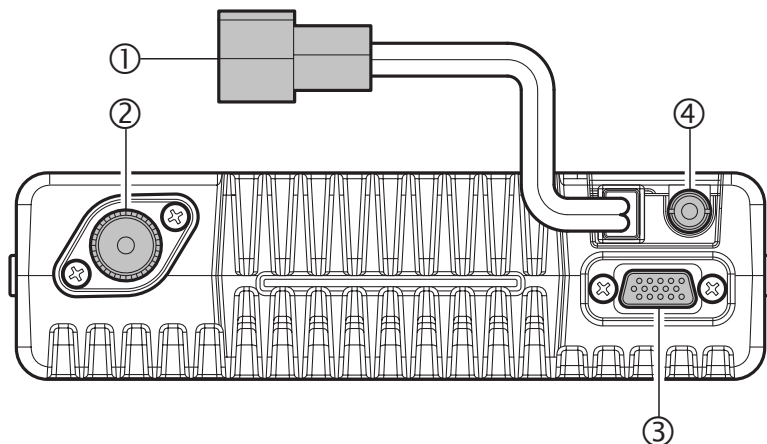

① 13.6V DC Cable Pigtail with Connector

The supplied DC power cable must be connected to this 2-pin connector. Use only the supplied fused cable, extended if necessary, for power connection.

② Antenna Socket

The 50-Ohm coaxial feedline to the antenna must be connected here, using a type-M (PL-259) plug.

③ D-Sub 15-Pin Accessory Connector

External TX audio line input, PTT (Push To Talk), Squelch, and external RX audio line output signals may be obtained from this connector for use with accessories such as data transmission/reception modems, and external Group control input etc.

④ External Speaker Jack

An external loudspeaker may be connected to this 2-contact, 3.5-mm mini-phone jack.

Caution: Do not connect either wire of this line to ground, and be certain that the speaker has adequate capability to handle the audio output (12 W) from the radio.

NOTE

BASIC OPERATION OF THE TRANSCEIVER

Important! - Before turning on the radio the first time, confirm that the power connections have been made correctly and that a proper antenna is connected to the antenna jack.

Switching Power ON/OFF

- Turn the **VOL/PWR** knob turn on the radio. The display will become illuminated.
- Press the [▼]/[▲] button to choose the desired operating group. A group name will appear on the display. If you want to select an operating group from a different zone, press the **PF** (Programmable Function) button which is programmed to the Zone Up/Down feature to select the zone you want before selecting the operating group. See page 20 for more information on the Programmable Function keys.

Setting the Volume

- Turn the **VOL/PWR** knob clockwise to increase the volume, and counter-clockwise to decrease it.

Transmitting

CONVENTIONAL ZONE

- To transmit, monitor the channel and make sure it is clear.
THIS IS AN FCC REQUIREMENT!
- Press the **PF** button which is programmed to the Monitor feature to listen for channel activity.
- When receiving a call, transmit only after the incoming call ends. The radio cannot receive a call and transmit simultaneously.
- Press the **PTT** switch.
- If the channel is clear, the **TX/BUSY** indicator will glow red. The radio is now transmitting. While holding in the **PTT** switch, speak across the face of the microphone in a clear and normal voice. For best transmission, hold the microphone about 1-1/2 to 2 inches away from your mouth. Release the **PTT** switch to receive.
- If the Busy Lockout feature has been programmed on a group, the radio will not transmit when a carrier is present. Instead, the radio will generate a short beep three times and indicate “**ERROR**” on the display. Release the **PTT** switch and wait for the channel to be clear of activity.
- If CTCSS or Digital Coded Squelch (DCS) Lockout has been programmed on a group, the radio can transmit only when there is no carrier being received or when the carrier being received includes the correct CTCSS tone or DCS code.

BASIC OPERATION OF THE TRANSCEIVER

LTR ZONE

- ❑ Press the **PTT** switch.
- ❑ When a group is available, the **TX/BUSY** indicator will glow red. The radio is now transmitting. While holding in the **PTT** switch, speak across the face of the microphone in a clear and normal voice. For best transmission, hold the microphone about 1-1/2 to 2 inches away from your mouth. Release the **PTT** switch to receive.
- ❑ If all groups are busy, a continuous tone will be heard from the radio, and the “**BUSY**” notation will appear on the display when the **PTT** switch is pressed. Release the **PTT** switch.
- ❑ If the radio is out of range during the transmitting attempt, slow beeps will be heard followed by a continuous tone from the radio.

Automatic Time-Out Timer

If the selected channel has been programmed for automatic time-out, you must limit the length of each transmission. While transmitting, a beep will sound 10 seconds before time-out. Another beep will sound just before the deadline; the red “**TX**” indicator will disappear and transmission will cease soon thereafter. To resume transmitting, you must release the **PTT** switch and wait for the “penalty timer” to expire (if you press the **PTT** switch before this timer expires, the timer restarts, and you will have to wait another “penalty” period).

ADVANCED OPERATION

Programmable Function (PF) Buttons

The **VX-2200(LTR)** Series includes six Programmable Function (**PF**) Buttons. The **PF** button functions can be customized, via programming by your Vertex Standard dealer, to meet your communications/network requirements. Some features may require the purchase and installation of optional internal accessories. The possible **PF** button programming features are illustrated below, and these functions are explained on the pages to follow. For further details, contact your Vertex Standard dealer. For future reference, check the box next to the function that has been assigned to each **PF** button on your particular radio, and keep it handy.

Function	PF Button (PRESS KEY/PRESS AND HOLD KEY)					
	P1	P2	P3	P4	▲	▼
MONI						
NSQ						
Lighting						
Group Up						
Group Down						
Continuous Group Up						
Continuous Group Down						
Zone Up						
Zone Down						
Continuous Zone Up						
Continuous Zone Down						
SCAN						
SCAN A/D						
LOW						
TA (Talk Around)						
Emergency						
CALL 1						
CALL 2						
Code Up						
Code Down						
Call/Reset						
Phone						
Public Address						
EXT. ACC1						
EXT. ACC2						
Short Cut to GP1						
Short Cut to GP2						
Short Cut to GP3						
Short Cut to GP4						
AF Min Vr						
HORN						
Key Lock						
Option SW*						
Encryption						

*: Requires FVP-35 Optional Unit

ADVANCED OPERATION

Description of Operating Functions

MONI (MONITOR)

Press (or press and hold) the assigned **PF** key to cancel CTCSS- and DCS-controlled squelch; the **TX/BUSY** indicator will glow green

NSQ

Press (or press and hold) the assigned **PF** key to open the SQL to hear background noise (unmute the audio); the **TX/BUSY** indicator will blink green.

LIGHTING

Press (or press and hold) the assigned **PF** key to select the brightness level of the display. Available selections are four levels.

GROUP UP/DOWN

Press (or press and hold) the assigned **PF** key (generally the [▼]/[▲] button) to select a different group within the current zone.

CONTINUOUS GROUP UP/DOWN

Press and holding in the assigned **PF** key causes the radio to begin stepping (repeatedly) upward or downward through the groups.

ZONE UP/DOWN

Press (or press and hold) the assigned **PF** key to select a different zone of groups.

CONTINUOUS ZONE UP/DOWN

Press and holding in the assigned **PF** key causes the radio to begin stepping (repeatedly) upward or downward through the zones.

ADVANCED OPERATION

SCAN

The Scanning feature is used to monitor multiple channels programmed into the transceiver. While scanning, the transceiver will check each group which is programmed with scan memory “Enabled” for the presence of a signal, and will stop on a channel if a signal is present.

To activate scanning:

- Press (or press and hold) the assigned **PF** key to activate scanning.
- The scanning radio will search the programmed groups, looking for active ones; it will pause each time it finds a group on which someone is speaking.
- Press (or press and hold) the assigned **PF** key again to disable scanning. Operation will revert to the Scan Start Group.

SCAN A/D

Press (or press and hold) the assigned **PF** key to delete the Current Memory Group from the Scanning. When you delete a group, “- SKIP-” will appear on the display for one second after pressing the assigned **PF** key. To restore a particular group to your scanning list, press (or press and hold) the assigned **PF** key again; “-STOP-” will appear on the display for one second after pressing the assigned **PF** key.

LOW (LOW POWER)

Press (or press and hold) the assigned **PF** key to set the radio’s transmitter to the “Low Power” mode. Press (or press and hold) the **PF** key again to return to “High Power” operation when in difficult terrain.

When the radio’s transmitter is set to “Low Power” mode, the “**Low**” icon will be indicated on the display.

TA (TALK AROUND)

Press (or press and hold) the assigned **PF** key to activate the Talk Around feature when you are operating on a duplex group (separate receive and transmit frequencies, utilizing a “repeater” station) which is programmed with “Talk Around (by user)” Enabled. The Talk Around feature allows you to bypass the repeater station and talk directly to a station or a radio that is nearby. This feature has no effect when you are operating on “simplex” groups, where the receive and transmit frequencies are already the same.

When the “TA” function is activated, the “” icon will be indicated on the display.

ADVANCED OPERATION

EMERGENCY

The **VX-2200(LTR)** series include an “Emergency” feature which may be useful if you have someone monitoring on the same frequency as your transceiver’s channel.

Press (or press and hold) the assigned **PF** key to initiate an emergency call. For further details contact your Vertex Standard dealer.

CALL 1/2

Press (or press and hold) the assigned **PF** key to send a 5-Tone sequential burst which is pre-defined.

CODE UP/DOWN

Press (or press and hold) the assigned **PF** key to select a 5-Tone encode code from pre-defined encode list.

CALL/RESET

When this feature is programmed and a selective call has been received, press the assigned **PF** key to reset the flashing indicator and mute the receiver; otherwise press the assigned **PF** key to send your radio’s identification code (ANI) to the dispatcher.

PHONE

Press (or press and hold) the assigned **PF** key to dial the Dealer pre-programmed Auto-Dial telephone number. The DTMF tones sent during the dialing sequence will be heard in the speaker.

PUBLIC ADDRESS

Press (or press and hold) the assigned **PF** key to use the transceiver as a PA amplifier. When you enable this function, a tone sounds and “**PA**” notation will appear on the display. The public address can be used even while scanning and receiving a call.

EXT. ACC1

During pressing and holding the assigned **PF** key, activates the optional device. It works as a momentarily action.

EXT. ACC2

Press (or press and hold) the assigned **PF** key to toggle the optional device “on” and “off.”

ADVANCED OPERATION

SHORT CUT TO GP1/GP2/GP3/GP4

Press (or press and hold) the assigned **PF** key to recall the Dealer pre-programmed group directly.

AF MIN VR

Press (or press and hold) the assigned **PF** key to reduce the audio output to the (lower) level programmed by your Dealer.

HORN

Press (or press and hold) the assigned **PF** key to turn the Horn Alert function “ON” or “OFF.” If you receive a call from the base station with 5-Tone, DTMF signaling, or Sub-Audible, horn alert will be activated and your vehicles horn will sound.

When you turn the Horn Alert “ON,” a tone will sound.

KEY LOCK

Press (or press and hold) the assigned **PF** key to lock the various aspects of the transceiver’s keys. The precise lockout configuration must be programmed by your Vertex Standard dealer.

OPTION SW

This function is usable only when a **FVP-35** Optional Unit is installed. It is used to toggle “on” or “off” the Rolling Encryption feature of the **FVP-35**.

ENCRYPTION

This function is usable on groups whose encryption feature is programmed to “Key On” or “Power On”. It is used to toggle “on” or “off” the built-in Encryption feature.

ADVANCED OPERATION

ARTS (Auto Range Transpond System)

This system is designed to inform you when you and another ARTS-equipped station are within communication range.

During ARTS operation, when the radio receives an incoming ARTS signal, a short beep will sound, and “**IN SVC**” (“In Service”) notation will be displayed on the display for 2 seconds. If you move out of range for more than two minutes, your radio senses that no signal has been received; a short triple-beep will sound, and “**OUT SVC**” (“Out of Service”) notation will be displayed on the display for 2 seconds. If you subsequently move back into communication range, as soon as the other station transmits, a short beep will sound and “**IN SVC**” notation will be displayed again on the display for 2 seconds.

DTMF Paging System

This system allows paging and selective calling, using DTMF tone sequences.

When your radio is paged by a station bearing a tone sequence which matches yours, your radio’s squelch will open and the alert will sound. The three-digit code of the station which paged you will be displayed on your radio’s display.

Note: In LTR Mode, the ability to transmit the DTMF ANI when releasing the **PTT** switch is disabled.

5-Tone System

This system is designed for 5-Tone SQL Controlling or STUN/KILL/REVIVE features.

When your radio receive the STUN/KILL code, your radio will get into STUN/KILL status. When the radio is in the STUN status, the radio is not usable till a radio receives a REVIVE code. When the radio is in the KILL status, the radio is not usable, please bring the radio to your Vertex Standard dealer.

OPTIONAL ACCESSORIES

MH-67A8J	Standard Microphone
MH-75A8J	16 Keypad Microphone
MD-12A8J	Desktop Microphone
MLS-100	External Speaker (12 W Peak Power)
MLS-200	External Speaker (15 W Peak Power)
FP-1023A	External Power Supply (13.8 VDC 23 A)
LF-1	Line Filter
FVP-35	High Level Encryption Unit
VPL-1	Programming Kit (Computer to PC)
CE94	PC Programming Software
FIF-12	USB Programming Interface
CT-171	Connection Cable for FIF-12

Availability of accessories may vary; some accessories are supplied standard per local requirements, others may be unavailable in some regions.

Check with your VERTEX STANDARD Dealer for changes to this list.

WARRANTY POLICY

Vertex Standard warrants, to the original purchaser only, its Vertex Standard manufactured communications products against defects in materials and workmanship under normal use and service for a given period of time from the date of purchase.

Limited Warranty Details:

- North America customers (USA and Canada):
<http://www.vertexstandard.com/lmr/warranty-terms.aspx>
- Customers outside of North America:
Contact the authorized dealer in your country.

NOTE

Part 15.21: Changes or modifications to this device not expressly approved by Vertex Standard could void the user's authorization to operate this device.



No portion of this manual may be reproduced without the permission of Vertex Standard LMR, Inc.

Vertex Standard is a trademark of Vertex Standard LMR, Inc.
All other trademarks are the property of their respective owners.

©2015 Vertex Standard LMR, Inc.
All rights reserved.

Printed in China

